

# A revision of the spider genera *Belippo* and *Myrmarachne* (Araneae: Salticidae) in the Ethiopian region

F. R. Wanless

Department of Zoology, British Museum (Natural History), Cromwell Road, London SW7 5BD

## Contents

Synopsis . . . . .	1
Introduction . . . . .	1
Methods and terminology . . . . .	2
Abbreviations of depositories . . . . .	3
Revision of genera . . . . .	5
The genus <i>Belippo</i> . . . . .	5
Definition . . . . .	5
Diagnosis . . . . .	7
Biology . . . . .	7
Key to species . . . . .	7
The genus <i>Myrmarachne</i> . . . . .	18
Definition . . . . .	19
Diagnosis . . . . .	19
Species groups . . . . .	19
Variation . . . . .	20
Biology . . . . .	21
Distribution in the Ethiopian region . . . . .	23
Key to species . . . . .	23
Species Incertae sedis . . . . .	126
Unavailable names . . . . .	126
Acknowledgements . . . . .	126
References . . . . .	135
Index . . . . .	137

## Synopsis

The spider genera *Belippo* Simon and *Myrmarachne* Macleay in the Ethiopian region are revised. All the 7 known species of *Belippo* (of which 2 are new) and 56 known species of Ethiopian *Myrmarachne* (of which 24 are new) are described and figured. Biological and distributional data are given and separate keys to the species are provided. In *Myrmarachne* certain species groups based on the structure of the genitalia are proposed. The type-material (including 60 holotypes) of 84 nominate species was examined and 23 lectotypes and 1 neotype are newly designated. One generic and 21 specific names are newly synonymized and 6 new combinations are proposed.

## Introduction

The Salticidae is a large, well-defined cosmopolitan family of spiders with most species in the warmer regions of the world. More than 3000 species, classified in about 400 genera, have been described but a large proportion of these cannot be recognized with certainty on the basis of the existing literature.

The genera of this family were grouped by Simon (1901) into three artificial sections, the Pluridentati, Unidentati and Fissidentati, based on the dentation on the lower margin of the chelicerae.

Such a system of classification is unacceptable, as Prószyński (1971a) has already pointed out, but a more natural system cannot be proposed until existing genera have been revised. This paper, the first of a proposed series on the Salticidae, revises the ant-like genera *Belippo* and *Myrmarachne* in the Ethiopian region.

*Belippo* Simon, 1910, was formally monotypic but in the present paper it has been redefined and expanded to include seven species that are all West African in distribution.

*Myrmarachne* Macleay, 1838, contains at present 164 species. Although the genus is cosmopolitan only 9 species have been described from the New World, all from the Neotropical region (Galiano, 1969, 1974). In the Ethiopian region 58 species are now known and according to Roewer (1954) there are 12 species in the Palaearctic region, 76 species in the Oriental region and 9 species in the Australian sub-region. Provisional studies suggest that the Oriental region will prove to be far richer in species of this genus than our present knowledge indicates.

Simon (1886) described the first species of *Myrmarachne* from Africa and six years later Peckham & Peckham (1892) described the first Madagascan species in an early review of ant-like Salticidae. In their study, all of the known ant-like salticid genera were redefined mainly on the general form of the carapace and on the size and position of the eyes; they also proposed numerous new species and several new genera including *Iola* and *Hermosa*. In proposing his classification of the family Salticidae, Simon (1901) redefined *Myrmarachne* and made it the type of a suprageneric group, the 'Myrmarachneae'. He synonymized *Iola* and *Hermosa* with *Myrmarachne* and transferred a number of the Peckhams' species which had been described in *Salticus* to *Myrmarachne*. In a supplement to his main work, Simon (1903) described a new genus *Bizone* for an unusual Madagascan species. After the pioneer works of Simon and the Peckhams there followed a period in which many new species were described and several important papers by Szombathy (1913, 1915), Lessert (1925a, 1925b, 1942), Berland & Millot (1941) and Lawrence (1938, 1941) did much to increase our knowledge of the species in the Ethiopian region. *Myrmarachne* is now one of the largest genera in the Salticidae and includes more species than any of the other ant-like salticid genera. In 1965 Roewer revised *Myrmarachne* in the Ethiopian region as part of his studies on the Lyssomanidae and Salticidae-Pluridentati. Roewer's work, published posthumously, is unsatisfactory, the descriptions and figures are inadequate and the key to *Myrmarachne* is based on unreliable characters. Of the 22 new species of *Myrmarachne* described by Roewer, 12 have been synonymized in this present work.

Mimicry in spiders has been reviewed by Peckham (1889), Pocock (1909) and Brignoli (1966). Hingston (1927) has described behaviour in several unidentified Indian *Myrmarachne*. However, our knowledge of the biology of this genus is largely based on the excellent studies of Mathew (1934, 1940, 1954) on *M. platalooides* (O. P.-Cambridge), from India, and Collart (1929a, 1929b, 1941) on *M. foenisex* Simon, from Africa. Additional observations on *M. platalooides* have been made by Bhattacharya (1939) on moulting and metamorphosis, and Marson & Carpenter (1946) and Marson (1947) on behaviour.

## Methods and terminology

Specimens were examined in a dish of alcohol, the bottom of which was covered with glass beads. The drawings, except those of the vulvae, were made with the aid of a camera lucida attached to a dissecting microscope. The epigyne and male left palp (when present) were removed for study. After drawing, the epigyne was cleared in warm lactic acid on a well slide and redrawn with the aid of a camera lucida attached to a compound microscope. It was then returned to alcohol and the genitalia stored in micro-vials. Specimens used for scanning electron microscopy were air dried and vacuum coated with gold before examination.

The synonymy only includes more important citations and references of nomenclatorial significance; for complete synonymy see Bonnet (1945-61).

The terminology is explained in Figs 1-3 and examples of microsculpture are shown in a series of scanning electron micrographs (Pls 1-3). The terms used to describe microsculpture are sometimes difficult to interpret as they have been used in different senses by various authors (Eady, 1968). This is not surprising as the scanning electron microscope reveals detail that is far beyond

the resolution of the dissecting microscope. All the specimens examined in this study exhibit more than one form of microsculpture which may intergrade to form complex patterns or abruptly change from one type of sculpture into another. Fine reticulate forms of sculpture, which often occur on the thoracic part, cannot always be resolved with the dissecting microscope and it is often difficult to decide which form of sculpturing is present, particularly as lighting effects can cause an apparent reversal of reticulate and papillate structure. A similar effect can even be illustrated by viewing Pl. 1h upside down. The most common patterns that can normally be seen with the dissecting microscope are punctured-reticulate (Pl. 1a, b), especially within the eye region, and rugulose with irregular cross furrows (Pl. 1c, d) on the dorsal surface of the chelicerae. Other widespread but less conspicuous patterns are alutaceous on the abdomen (Pl. 1g) and raised reticulate on the sternum (Pl. 1e, f). Papillae (Pl. 3c, d) are probably more widespread than I have indicated in the descriptions as they may have been overlooked; the thoracic papillae of *Myrmarachne marshalli* Peckham & Peckham and *M. legon* sp. n. were not noticed until specimens were examined with the stereoscan microscope. Rippling (Pl. 2d), smooth and irregular punctures (Pl. 2b) are fairly rare but sometimes clear enough to be used as a diagnostic character.

The measurements, which are accurate to 0.05 mm, were made with an eyepiece micrometer and the system used is explained in Figs 1–2. There is no point in always giving absolute measurements (e.g. in mm) as their principal value is in their relation to the measurements of other parts. Eye size is expressed in ratios made from the type-specimen but variation is not given. Four standard abbreviations, AM, AL, PM, PL, refer respectively to the anterior median, anterior lateral, posterior median and posterior lateral eyes. Eye interdistances are denoted by dashes, i.e. PM–PL refers to the distance between the posterior median and posterior lateral eyes. Eye ratios refer to the diameter of the lens and not the encircling pigment which is normally present.

From the measurements several indices are derived:

- a: width of eye row I/carapace width at that point; decreasing values below 1.0 indicate a space between the anterior lateral eyes and the sides of the carapace at that point.
- b: width of eye row III/carapace width at that point; increasing values above 1.0 indicate that the posterior lateral eyes project over the sides of the carapace at that point.
- c: quadrangle length/carapace length; a value of 0.50 indicates that the eye region and thoracic part are of equal length.
- d: chelicerae length (males only)/carapace length; increasing values above 1.0 indicate that the chelicerae are longer than the carapace.
- e: tibia plus patella IV/carapace length; decreasing values below 1.0 indicate that the tibia plus patella IV are shorter than the carapace.

The indices a, b and d exhibit a greater range of variation in males and are good indicators of allometric growth. Ratio c is less variable but it is sometimes used as a diagnostic character. Ratio e is the most useful index to be derived from measuring the leg segments of type-specimens, it is rather variable but can be useful for separating closely related females. All indices can be derived from whole specimens and dissection is not necessary. In the figures the palpal setae have not been included in order to show the shape of the tibial apophysis clearly.

### Abbreviations of depositories

BMNH	British Museum (Natural History), London
CNR, Florence	Consiglio Nazionale delle Ricerche, Università Degli Studi di Firenze, Firenze, Italy (Dr A. Martelli)
FS, Frankfurt am Main	Forschungsinstitut Senckenberg, Natur-Museum, Senckenberg, Frankfurt am Main, West Germany (Dr M. Grasshoff)
MB, Lisbon	Museu Bocage, Lisbon, Portugal (Dr J. de A. Fernandes)
MCSN, Genoa	Museo Civico di Storia Naturale, Genoa, Italy (Dr L. Capocaccia, Dr R. Poggi and Professor E. Tortonese)
MCZ, Cambridge	Museum of Comparative Zoology, Harvard University, Cambridge, Massachusetts, U.S.A. (Professor H. W. Levi)
MD, Dundo	Museo do Dundo, Dundo, Luanda, Angola (Dr A. de Barros Machado)
MHN, Geneva	Muséum d'Histoire Naturelle, Geneva, Switzerland (Dr B. Hauser)



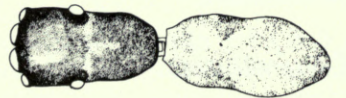
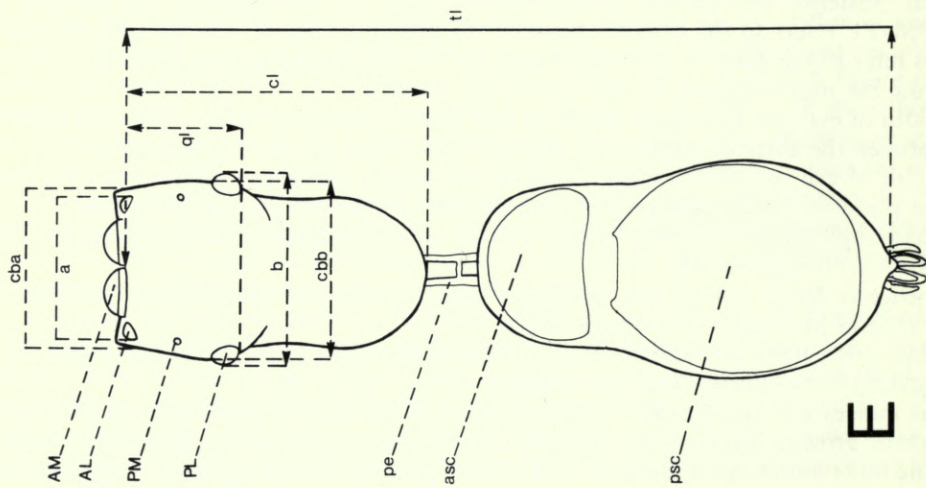
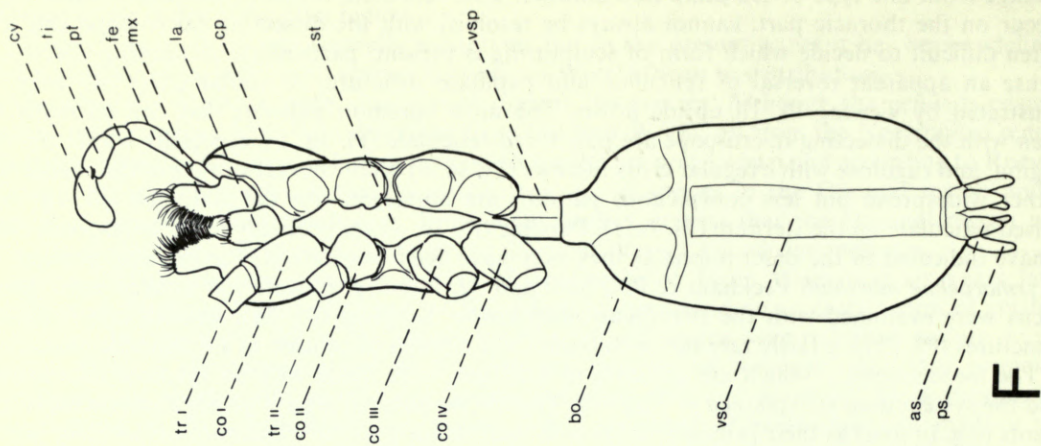

**A**



**B**



**C**

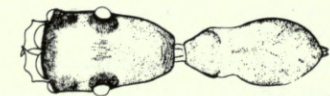

**D**



MNHN, Paris	Muséum National d'Histoire Naturelle, Paris, France (M M. Hubert)
MNHU, Berlin	Museum für Naturkunde der Humboldt-Universität, Berlin, East Germany (Dr M. Moritz)
MRAC, Tervuren	Musée Royal de l'Afrique Centrale, Tervuren, Belgium (Professor P. L. G. Benoit)
NM, Pietermaritzburg	Natal Museum, Pietermaritzburg, South Africa (Mr B. Lamoral)
NR, Stockholm	Naturhistoriska Riksmuseet, Stockholm, Sweden (Professor T. Kronstedt)
TM, Budapest	Természettudományi Múzeum Állattára, Budapest, Hungary (Dr S. Mahunka)
ZIZM, Hamburg	Universität Hamburg, Zoologisches Institut und Zoologisches Museum, Hamburg, West Germany (Dr G. Rack)

## Revision of genera

### Genus *BELIPPO* Simon

*Belippo* Simon, 1910 : 416. Type-species *Belippo anguina* Simon, by monotypy. Roewer, 1954 : 939 Bonnet, 1955 : 875. Roewer, 1965 : 78.

The present status of *Belippo* is based on the assumption that the male of *Belippo anguina* Simon (the type-species) will prove to have a movable apophysis on the palpal tibia and thus agree with the definition given below.

**DEFINITION.** Ant-like spiders ranging from about 3.5 to 7.0 mm in length. Males sexually dimorphic. *Carapace*: shape variable; constriction usually shallow with two dorsal trichobothria but lateral wedge-shaped patches of whitish hairs lacking (cf. *Myrmarachne*); sculpturing variable; colour patterns usually lacking; not hirsute. *Eyes*: anterior row subcontiguous or contiguous with apices procurved or level in frontal view; middle row midway or nearly midway between anterior lateral and posterior lateral eyes; posterior row equal to or wider than anterior row; quadrangle length between 45 and 50 per cent of carapace length (cf. *Myrmarachne*). *Clypeus*: very low. *Female chelicerae*: normal with 4 or 5 promarginal and 5–7 retromarginal teeth; *Male chelicerae*: strongly developed, porrect or slightly porrect, not grossly elongate; spurs present; fang apophysis absent; groove with 3 or 4 promarginal and 6–8 retromarginal teeth. *Maxillae*: elongate, more or less parallel. *Labium*: elongate. *Sternum*: elongate. *Pedichel*: moderately long. *Abdomen*: shape variable; constriction present or absent, sometimes reinforced with

**Fig. 1** (A, B) generalized body form of *Belippo* in dorsal view (legs and palps omitted): (A) ♂; (B) ♀. (C, D) generalized body form of *Myrmarachne* in dorsal view (legs and palps omitted): (C) ♂; (D) ♀. (E, F) structure of *Myrmarachne* (schematic); (E) dorsal view; (F) ventral view.

Explanation of abbreviations in Figs 1–3. *a*, breadth of eye row I; *adsp*, anterior dorsal segment of pedichel; *ag*, accessory gland; *AL*, anterior lateral eye; *AM*, anterior median eye; *as*, anterior spinneret; *asc*, anterior scutum; *b*, breadth of eye row III; *bo*, branchial operculum; *bt*, bristle tuft; *cba*, carapace breadth at level of anterior lateral eyes; *cbb*, carapace breadth at level of posterior lateral eyes; *ch*, chelicera; *chl*, cheliceral length; *cl*, carapace length; *cly*, clypeus; *co*, coxa; *con*, constriction; *cp*, cephalic part of head; *cym*, cymbium; *da*, distance between anterior lateral and posterior median eye; *dal*, diameter of anterior lateral eye; *dam*, diameter of anterior median eye; *de*, depression for protection of embolus; *dp*, distance between posterior median and posterior lateral eye; *dpl*, diameter of posterior lateral eye; *dps*, distal prolateral spur; *dsd*, distal seminal duct; *ef*, epigastric fold; *emb*, embolus; *ep*, epigyne; *f*, flange of retrolateral tibial apophysis; *fa*, fang apophysis; *fch*, female chelicera; *fe*, femur; *fg*, fang; *la*, labium; *lp*, lateral pouch; *lt<sub>p</sub>*, length of tibia plus patella but measured on leg IV; *mch*, male chelicera; *meo*, margin of epigynal opening; *mmc*, modified margin of cymbium; *ms*, median spinneret; *mt*, metatarsus; *mta*, movable tibial apophysis; *mx*, maxilla; *odsd*, opening of distal seminal duct; *pe*, pedichel; *pd*, proximal depression; *PL*, posterior lateral eye; *PM*, posterior median eye; *pp*, pars pendula of the embolus; *pr*, proximal seminal duct; *p<sub>rt</sub>*, prolateral teeth; *ps*, posterior spinneret; *psc*, posterior scutum; *pt*, patella; *psp*, primary spermatheca; *ql*, quadrangle length; *rs*, retrolateral spur; *rt*, retrolateral teeth; *sd*, seminal duct; *sp*, spermatheca; *sr*, seminal reservoir; *ssp*, secondary spermatheca; *ta*, tarsus; *tap*, tibial apophysis; *td*, tibial denticles; *teg*, tegulum; *ti*, tibia; *tl*, total length; *tp*, thoracic part of thorax; *tr*, trochanter; *vsp*, ventral segment of pedichel.

scanty band of whitish hairs; scuta present in males, lacking or vestigial in females. *Legs*: slender, femora I dorsoventrally enlarged and slightly compressed laterally; formula 4132; dorsal and lateral spines absent, ventral spines present on legs I and II but usually absent on legs III and IV. Claw tufts present but scopula lacking. *Female palp*: pallet-shaped. *Male palp* (Fig. 3A, C): with movable tibial apophysis and fixed retrolateral denticles. Embolus long and slender with two turns around the tegulum; the tip sometimes modified (Fig. 8F, G). Pars pendula present but conductor and median apophysis lacking. Tegulum subcircular with large seminal reservoir; cymbium with proximal ectal margin excavated or otherwise modified. *Epigyne* (Fig. 3B): comparatively simple with paired or unpaired openings and lateral pouches that are sometimes poorly defined or reduced (Figs 4F, 6I). Primary and secondary spermathecae present, connected by

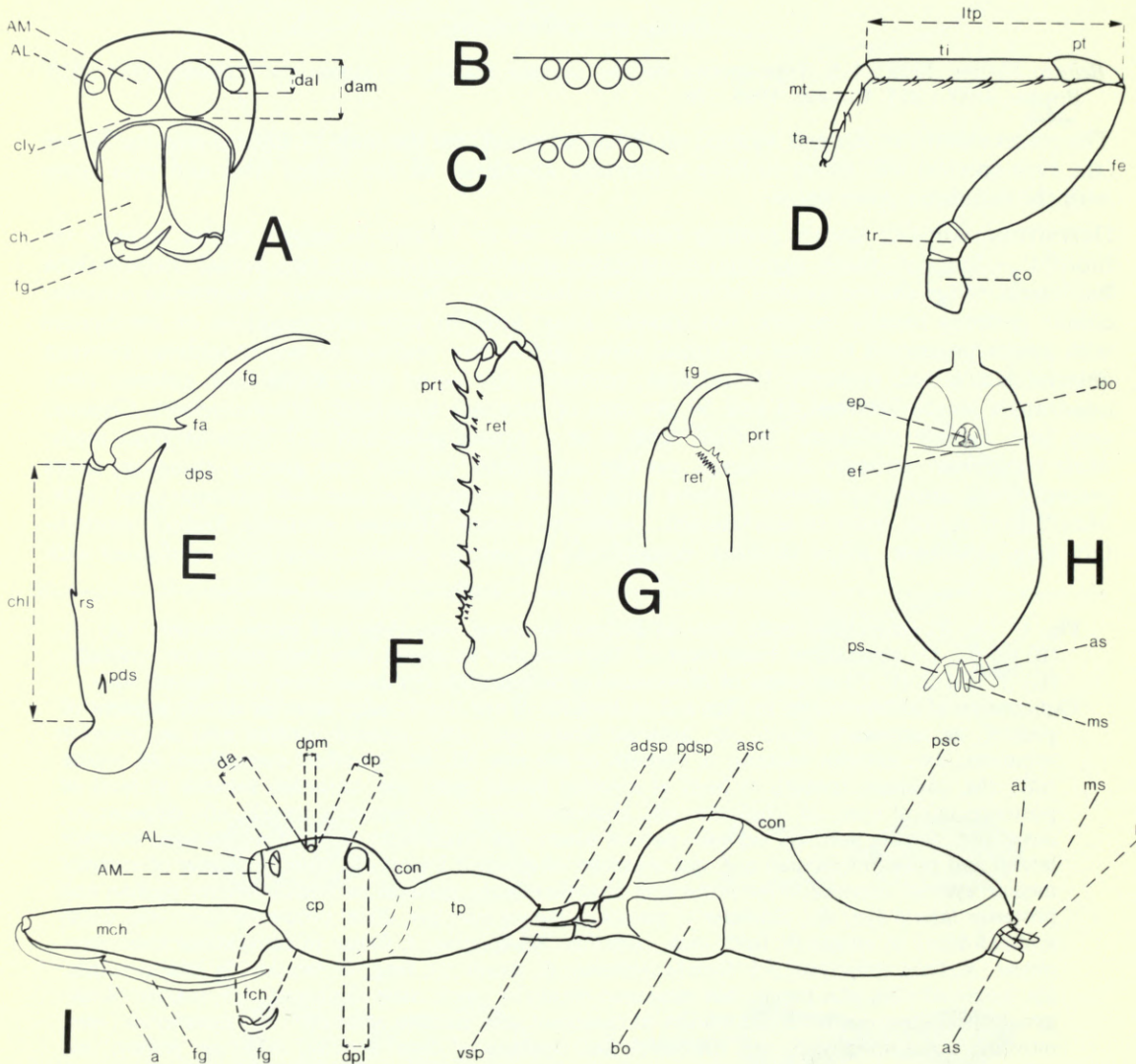

**Fig. 2** Structure of *Myrmarachne* (schematic): (A) cephalothorax in facial view; (B) eye row I with apices level in frontal view; (C) eye row I with apices procurved in frontal view; (D) leg I; (E) ♂ chelicera in dorsal view; (F) ♂ chelicera in ventral view; (G) ♀ chelicera in ventral view; (H) ♀ abdomen in ventral view; (I) lateral view. For explanation of abbreviations, see caption to Fig. 1.



median seminal ducts; the primaries distinguished by dorsal accessory glands; the secondaries very variable in shape and sometimes forming amorphous masses (Figs 6I, J; 7J, K).

The structure of the epigyne is not entirely clear as the opening for the reception of the embolus has not been located. The apparent distinction between globular and amorphous secondary spermathecae suggests the possibility of species groups but correlated differences in male palp structure are not evident.

**DIAGNOSIS.** *Belippo* is separated from *Myrmarachne* by the movable tibial apophysis on the male palp and the presence of secondary spermathecae in females. A fuller diagnosis cannot be given until related genera have been revised. Its affinities are uncertain and at present I do not know of another salticid genus which has a movable apophysis on the palpal tibia. The presence of secondary spermathecae is also unusual although they are also found in *Sarinda* Peckham & Peckham, 1892, an unrelated genus of ant-like Salticidae from the Neotropical region (Galiano, 1965).

**BIOLOGY.** *Belippo* spiders are morphologically ant-like and since *B. ibadan* sp. n. and *B. calcarata* (Roewer) have been found in association with several species of ant it seems reasonable to assume that they are ant-mimics. However, apart from a few scattered collectors' notes, nothing is known of their biology.

### Key to species of *Belippo*

#### Males

- 1 Palpal tibia clearly longer than broad (Fig. 5E) . . . . . *viettei* (Kraus) (p. 10)
- Palpal tibia about as long as broad (Figs 7M; 8H) . . . . . 2
- 2 Embolic tip shaped like a swan's head (Fig. 8F) . . . . . *cygniformis* sp. n. (p. 16)
- Embolic tip otherwise . . . . . 3
- 3 Embolic tip acuminate (Fig. 8G); abdomen with ventral scutum . . . . . *ibadan* sp. n. (p. 16)
- Embolic tip otherwise; abdomen without ventral scutum . . . . . 4
- 4 Movable apophysis with one barb (Fig. 6H, L); carapace more constricted (Fig. 6E, G) with rippling between PL . . . . . *calcarata* (Roewer) (p. 11)
- Movable apophysis with double barb (Fig. 7M); carapace less constricted (Fig. 7B) without rippling between PL . . . . . *milloti* (Lessert) (p. 13)

#### Females

- 1 Carapace with longitudinal brownish bands (Fig. 4A, B) . . . . . *anguina* Simon (p. 7)
- Carapace without longitudinal brownish bands . . . . . 2
- 2 Secondary spermathecae small and globular (Figs 4F, 9C, D) . . . . . 3
- Secondary spermathecae forming somewhat angular amorphous masses (Figs 6I, J; 7J, K) . . . . . 4
- 3 Epigynal openings and primary spermathecae subovate (Fig. 4F) . . . . . *nexilis* (Simon) (p. 9)
- Epigynal openings elongate, primary spermathecae rounded (Fig. 9C, D) . . . . . *ibadan* sp. n. (p. 16)
- 4 Carapace rippled between PL and with a more or less distinct thoracic hump (Fig. 6F) . . . . . *calcarata* (Roewer) (p. 11)
- Carapace not rippled between PL and without a distinct thoracic hump (Fig. 7G) . . . . . *milloti* (Lessert) (p. 13)

### *Belippo anguina* Simon

(Fig. 4A, B, D)

*Belippo anguina* Simon, 1910 : 416, young ♀. LECTOTYPE ♀ [not young ♀ as stated by Simon] (here designated), São Thomé, Agua Ize (MCSN, Genoa) [Examined]. Roewer, 1954 : 939. Bonnet, 1955 : 875. Roewer, 1965 : 78. Prószyński, 1971b : 384.

**DIAGNOSIS.** *Belippo anguina* is a distinctive species easily recognized by the elongate body form and carapace markings (Fig. 4A, B).

**MALE.** Unknown.

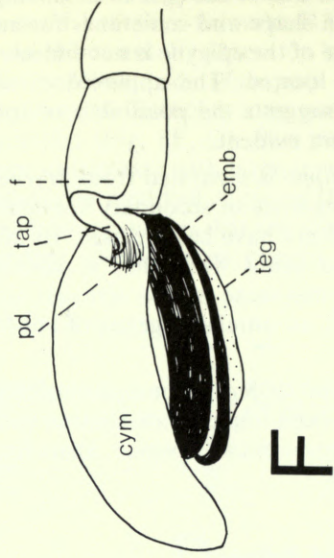
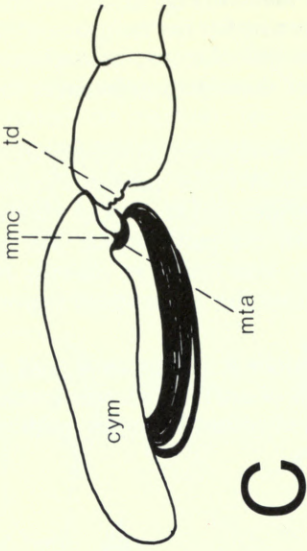
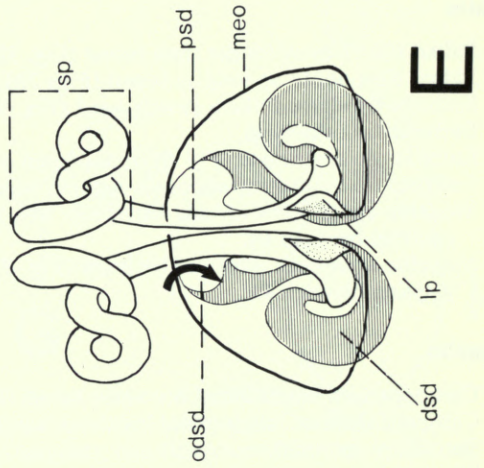
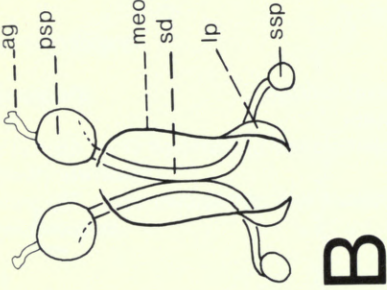
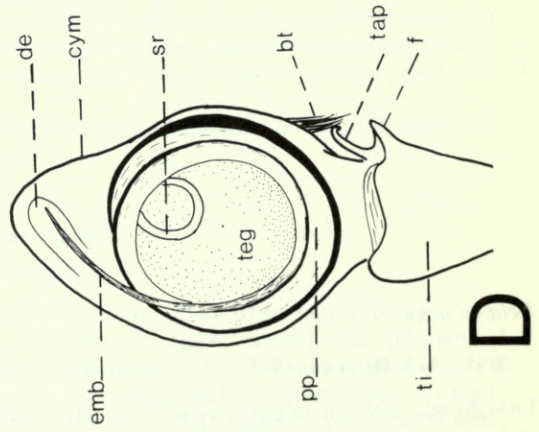
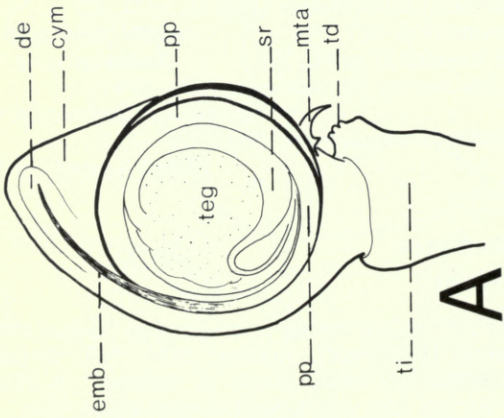



FEMALE. *Carapace* (Fig. 4A, B): light yellow with yellowish guanin in eye area and brownish lateral bands from clypeal region to posterior margin of thoracic part. *Eyes*: anteriors contiguous with apices slightly procurved, fringed with white hairs. *Clypeus*: sparsely white haired. *Chelicerae*: light yellow-brown; promargin with 4 teeth, retromargin with 5. *Maxillae and Labium*: light yellow. *Sternum*: elongate, margins poorly defined; whitish yellow. *Abdomen* (Fig. 4A): whitish yellow with ill-defined greyish yellow bands on the sides. Spinnerets grey-yellow. *Legs*: femora I slightly enlarged. Light yellow to whitish yellow. Ventral spination of legs I: metatarsi 2-2; tibiae 1-2-2-2-2; patellae 0. *Epigyne* (Fig. 4D): small and pale; vulva not examined.

*Dimensions*: total length 4.92 mm, carapace length 1.84 mm. *Ratios*: AM : AL : PM : PL: 8 : 4 : 1 : 4.5, AL-PM-PL: 6.5-6; a: 1.04, b: 1.05, c: 0.46, e: 0.80 (1 ♀ examined).

BIOLOGY. Unknown.

DISTRIBUTION. São Thomé.

MATERIAL EXAMINED. Lectotype ♀, data given in synonymy.

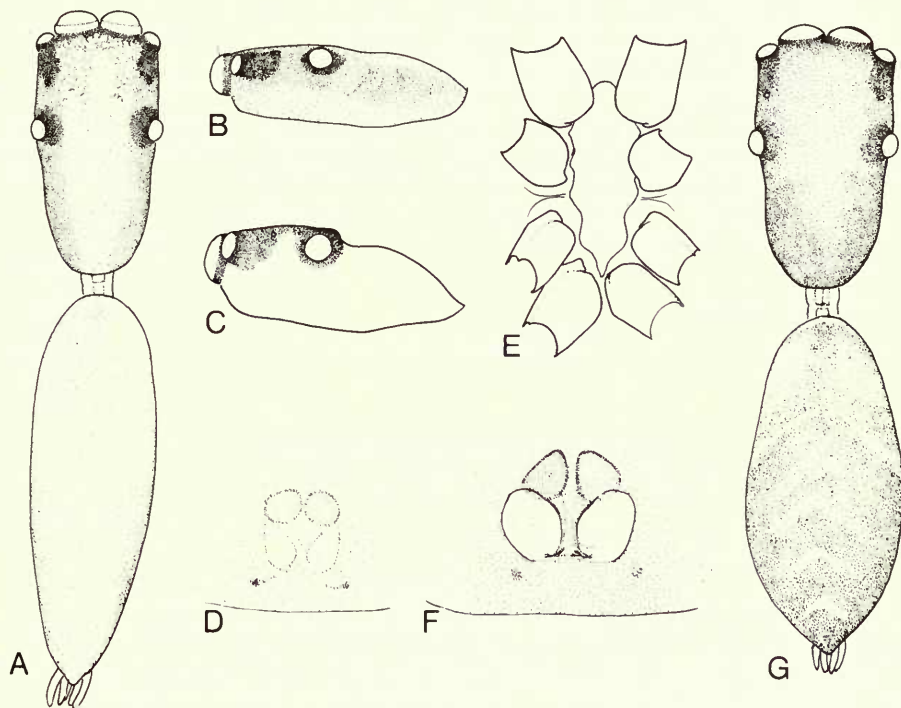

Fig. 4 (A, B, D) *Belippo anguina* Simon. Lectotype ♀: (A) dorsal view; (B) carapace, lateral view; (D) epigyne, ventral view. (C, E, F, G) *Belippo nexilis* (Simon). Lectotype ♀: (C) carapace, lateral view; (E) sternum; (F) epigyne, ventral view; (G) dorsal view.

*Belippo nexilis* (Simon) comb. nov.

(Fig. 4C, E-G)

*Myrmarachne nexilis* Simon, 1910 : 415, ♂♀. LECTOTYPE ♀ (here designated), São Thomé, Agua Izé and Ribeira Palma (MCSN, Genoa) [Examined]. Roewer, 1954 : 943. Bonnet, 1957 : 3010. Roewer, 1965 : 76. Prószyński, 1971b : 439.

When describing *M. nexilis*, Simon gave two localities in São Thomé, Agua Izé and Ribeira Palma, but did not specify the number of specimens. I have only been able to trace one female and

Fig. 3 Genitalia structure (schematic). (A, B, C) *Belippo*: (A) ♂ palp in ventral view; (B) ♀ epigyne in ventral view; (C) ♂ palp in retrolateral view. (D, E, F) *Myrmarachne*: (D) ♂ palp in ventral view; (E) ♀ epigyne in ventral view; (F) ♂ palp in retrolateral view. For explanation of abbreviations, see caption to fig. 1.

two male specimens labelled *M. nexilis*, in Simon's hand. The female bearing the locality label 'São Thomé, Igua Ize' is designated lectotype. The two males which were found together in the same vial with the locality label 'São Thomé' are not conspecific with the female or with each other but represent new taxa that are described elsewhere in this paper (see pp. 46, 88). However, one of the males (the specimen designated holotype of *Myrmarachne confusus* sp. n.) agrees more or less with Simon's original description of the male of *M. nexilis* particularly in respect of the club-shaped chelicerae and it is possible that this specimen is a paralectotype of *nexilis* in spite of the incomplete locality data.

**DIAGNOSIS.** *Belippo nexilis* is closely related to *B. anguina* Simon but it is easily distinguished by the more robust body form and lack of colour markings on the carapace (Fig. 4G).

**MALE.** Unknown but it is possible that *B. viettei* (Kraus) belongs with this species.

**FEMALE.** *Carapace* (Fig. 4C, G): eye region punctured-reticulate, thoracic part finely papillate; orange to reddish orange with dull metallic sheen on the head; sparsely covered with scattered white hairs. *Eyes*: anteriors subcontiguous with apices level, AM relatively large, fringed with fine brownish hairs. *Chelicerae*: orange, shiny; promargin with 5 teeth, retromargin with 6. *Maxillae and Labium*: orange but labial tip paler. *Sternum* (Fig. 4E): yellow-orange. *Abdomen* (Fig. 4G): greyish to orange-brown with ill-defined chevrons posteriorly and whitish band anteriorly. *Legs*: femora I slightly enlarged; light yellowish orange to brownish orange. Ventral spination of legs I: metatarsi 2-2; tibiae 1-2-2-2-2; patellae 0. *Epigyne* (Fig. 4F): small with openings evidently separated by median septum; vulva not examined.

*Dimensions*: total length 7.1 mm, carapace length 2.88 mm. *Ratios*: AM : AL : PM : PL : 14 : 8 : 1.5 : 8, AL-PM-PL: 10-8.5; a: 1.05, b: 1.6, c: 0.47, e: 0.93 (1 ♀ examined).

**BIOLOGY.** Unknown.

**DISTRIBUTION.** São Thomé.

**MATERIAL EXAMINED.** Lectotype ♀, data given in synonymy.

### *Belippo viettei* (Kraus) comb. nov.

(Fig. 5A-G)

*Myrmarachne viettei* Kraus, 1960 : 97, figs 9-12, ♂. Holotype ♂, São Thomé, Diogo Vaz, Monte das Quinas (MNHN, Paris) [Examined]. Roewer, 1965 : 76, fig. 48.

**DIAGNOSIS.** *B. viettei* is a species of uncertain affinities. It could be the male of *B. nexilis* (Simon) and may be closest to *B. anguina* Simon, also known only from the female. It is separated from other male *Belippo* by the presence of an abdominal pattern (which may be more distinctive in fresh specimens), the absence of retrolateral spurs on the chelicerae (Fig. 5C) and relatively elongate palpal tibiae (Fig. 5E-G).

**FEMALE.** Unknown.

**MALE.** *Carapace* (Fig. 5A, B): finely punctured-reticulate in eye region with thoracic part finely papillate; orange-brown to light orange-brown. *Eyes*: anteriors contiguous with apices slightly procurved, sparsely fringed with white hairs. *Clypeus*: white haired. *Chelicerae* (Fig. 5C, D): finely rugulose; yellow-brown, shiny; lateral keels dark brown with distal prolateral spur; fang apophysis lacking. *Maxillae and Labium*: light orange-brown, labium a shade darker. *Sternum*: light yellow. *Abdomen* (Fig. 5A, B): mottled yellowish grey with ill-defined pattern of pale spots and chevrons. *Legs*: femora I enlarged; legs I yellowish with metatarsi and sides of tibiae brownish. Other legs light yellow-brown with some darkening on apices of tibiae and patellae IV. Ventral spination of legs I: metatarsi 2-2, tibiae 2-2-2-2-2, patellae 0. *Palp* (Fig. 5E-G): light yellow; tibiae relatively long with 3 slender denticles.

*Dimensions*: total length 4.5 mm, carapace length 1.8 mm. *Ratios*: AM : AL : PM : PL : 9 : 4.8 : 1.5 : 5.5, AL-PM-PL: 6.8-5.8; a: 1.05, b: 1.05, c: 0.48, d: 0.28, e: 0.83 (1 ♂ examined).

**BIOLOGY.** Unknown.



DISTRIBUTION. São Thomé.

MATERIAL EXAMINED. Holotype ♂, data given in synonymy.

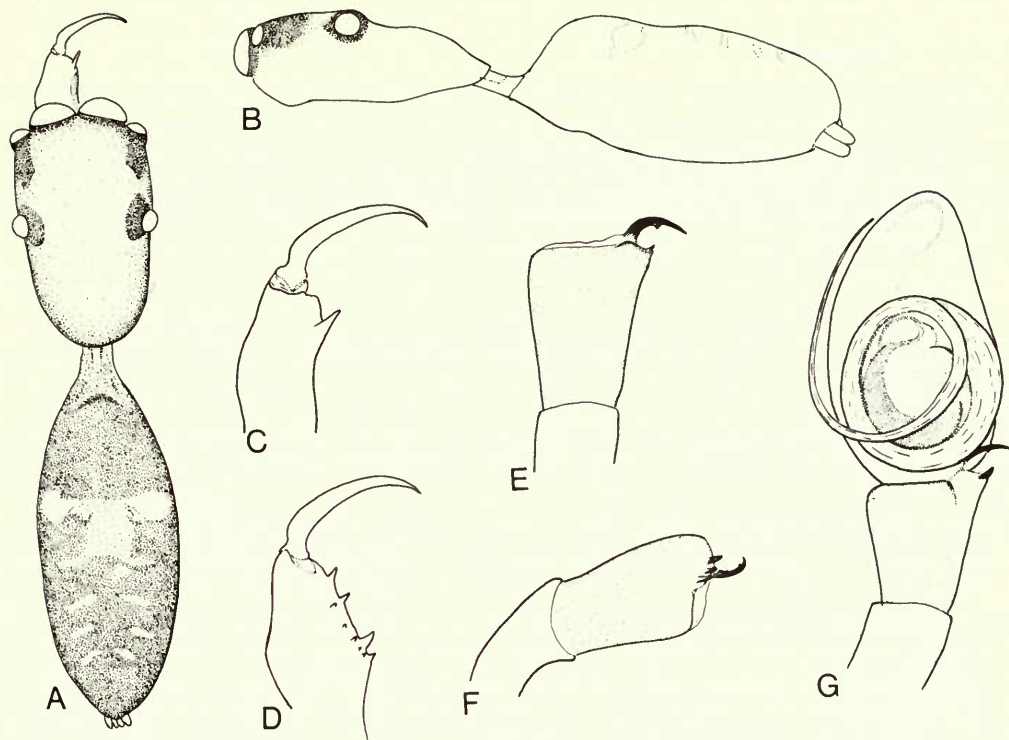

Fig. 5 *Belippo viettei* (Kraus). Holotype ♂: (A) dorsal view; (B) lateral view; (C) chelicera, dorsal view; (D) chelicera, ventral view; (E) palpal tibia, dorsal view; (F) palpal tibia, lateral view; (G) palp, ventral view.

*Belippo calcarata* (Roewer) comb. nov.

(Fig. 6A–L)

*Myrmarachne calcarata* Roewer, 1942 : 253, pl. 19, figs 9a, 9b, ♂. Holotype ♂, Fernando Po, Musola, 630 m (FS, Frankfurt am Main) [Examined]. Roewer, 1954 : 942; 1965 : 74, fig. 30. Prószyński, 1971b : 437.

DIAGNOSIS. *Belippo calcarata* is closely related to *B. milloti* (Lessert) but can be distinguished by the presence of rippling and papillae on the carapace and only one barb on the movable apophysis of the male palp (Fig. 6H, K, L).

MALE. *Carapace* (Fig. 6A, E, G): eye region punctured-reticulate with ripples between PL to finely, but densely papillate on thoracic part. *Eyes*: anteriors contiguous with apices slightly procurved, sparsely fringed with whitish hairs. *Clypeus*: sparsely white haired. *Chelicerae* (Fig. 6B, C): finely rugulose; yellow-brown, shiny; lateral keels dark brown with retrolateral and distal prolateral spurs; fang apophysis lacking. Spurs somewhat reduced in smaller individuals. *Maxillae and Labium*: yellow-brown, labium sometimes darker. *Sternum* (Fig. 6D): yellow-brown or orange-brown shiny. *Abdomen* (Fig. 6A, G): yellowish mottled with black; scuta light orange-brown suffused with some black, rather glossy with fine scattered hairs and 2 impressed dots; a pale yellow haired band in constriction. *Legs*: femora I enlarged; legs I light yellow-brown with brownish metatarsi and dark brownish femora. Legs II–III pale yellow-brown with inside of femora II and outside of patellae and femora III blackish. Legs IV light yellow-brown with sooty

marks on the sides of metatarsi, tibiae, patellae and femora. Ventral spination of legs I: metatarsi 2-2; tibiae 2-2-2-2 or 2-2-2-2-2; patellae 2 or 1. *Palp* (Fig. 6H, K, L): tibia with 3 or 4 denticles; embolus tip curved, sometimes scythe-like.

*Dimensions*: total length 2.88-3.30 mm; carapace length 1.37-1.60 mm. *Ratios*: AM:AL:PM:PL: 7:4:1:4, AL-PM-PL: 6-5; a: 1.04, b: 1.04-1.08, c: 0.47-0.50, d: 0.27-0.28, e: 0.77 (3 ♂ examined).

**FEMALE** (formerly undescribed). *Carapace* (Fig. 6F): anterior half of eye region finely rugulose, posterior half punctured-reticulate with ripples between PL; thoracic part as in ♂; orange-brown, shiny. *Eyes*: as in ♂. *Clypeus*: sparsely fringed with fine pale hairs. *Chelicerae*: finely rugulose; light yellowish, shiny; promargin with 4 teeth, retromargin with 7. *Maxillae and Labium*: light yellow. *Sternum*: light yellow. *Abdomen*: light yellowish. *Legs*: femora I enlarged. Generally

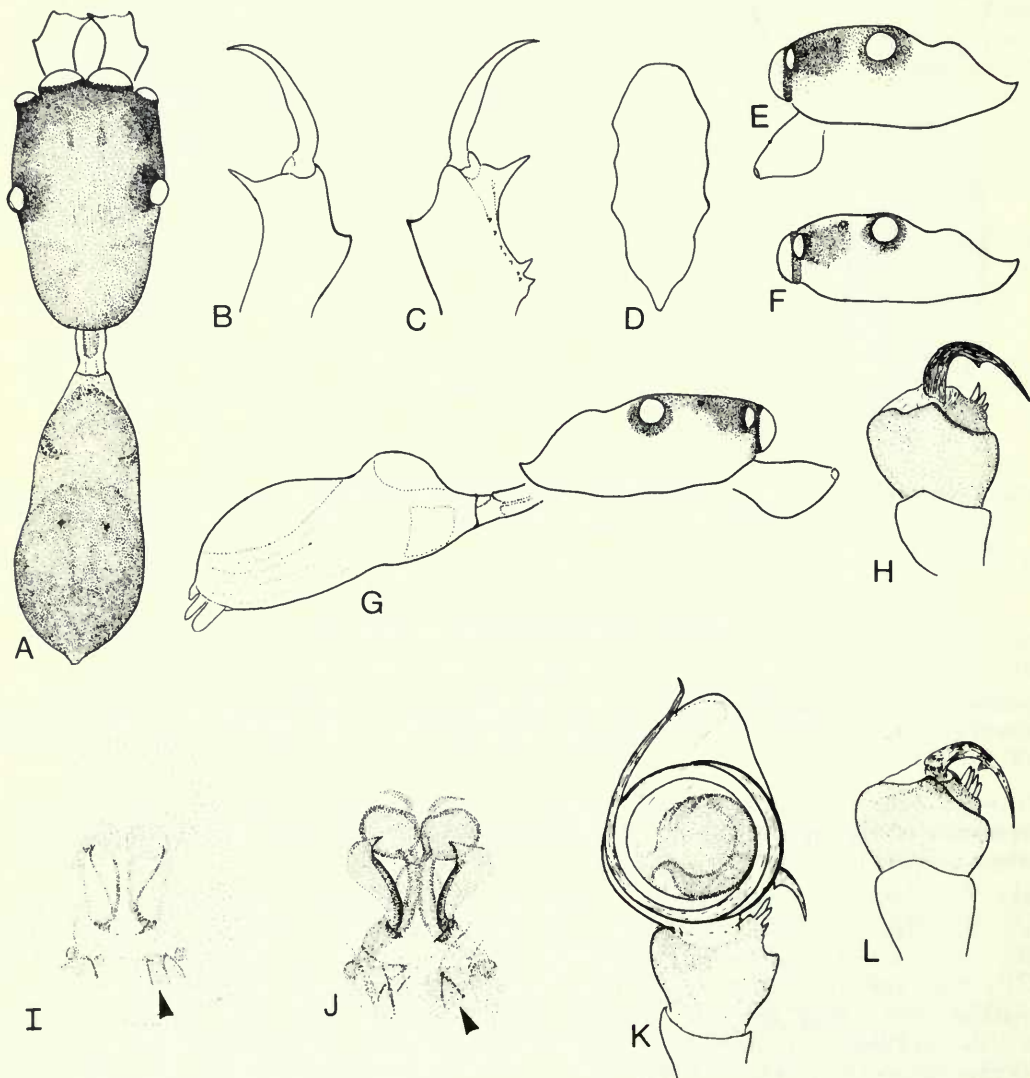

Fig. 6 *Belippo calcarata* (Roewer). Holotype ♂: (A) dorsal view; (B) chelicera, dorsal view; (C) chelicera, ventral view; (D) sternum; (G) lateral view; (H) palpal tibia, dorsal view; (K) palp, ventral view. ♂ from Angola: (E) carapace lateral view. ♀ from Angola: (F) carapace, lateral view; (I) epigyne, ventral view; (J) vulva, ventral view. ♂ from Zaire: (L) palpal tibia, dorsal view.



light yellowish to pale yellow-orange. Ventral spination of legs I: metatarsi 2-2; tibiae 2-2-2-2-2; patellae 2. *Epigyne* (Fig. 6I, J): rather pale with openings indistinct; secondary spermathecae forming somewhat angular amorphous masses.

*Dimensions*: total length 3.48 mm, carapace length 1.44 mm. *Ratios*: AM : AL : PM : PL : 8 : 4.5 : 1 : 4.5, AL-PM-PL: 5.5-4; a: 1.03, b: 1.08, c: 0.50, e: 0.78 (1 ♀ examined).

**BIOLOGY.** Professor Eidmann (Roewer, 1942) observes that this species when alive resembles *Pheidole* ants.

**DISTRIBUTION.** Angola, Fernando Po, Zaire.

**MATERIAL EXAMINED.** Holotype ♂, data given in synonymy. ANGOLA: Environs of Dundo, forest litter, R. Cambuacala, 1 ♂, 2.viii.1960 (*A. B. Machado*, Ang. 15903.2) (BMNH). Park Carrisso, in fallen rotting tree trunk, 1 ♀, 15/23.vi.1949 (*A. B. Machado*, DM. 1522.45) (BMNH). ZAIRE: Katanga, Mt Kabobo, Ht Kiyambi, 1700 m, 1 ♂, x.1958 (*N. Leleup*, MT 112760) (MRAC, Tervuren).

### *Belippo milloti* (Lessert) comb. nov.

(Fig. 7A-M)

*Myrmarachne milloti* Lessert, 1942 : 8, figs 1-4, ♂♀. LECTOTYPE ♂ (here designated), Zaire, Kivu, Tschibuida (MRAC, Tervuren) [Examined]. Roewer, 1954 : 943; 1965 : 48, fig. 30. Prószyński, 1971b : 439.

**DIAGNOSIS.** *Belippo milloti* is closely related to *B. calcarata*, from which it may be distinguished by the absence of rippling and papillae on the carapace and the presence of a double barb on the movable apophysis of the male palp (Fig. 7M).

**MALE.** *Carapace* (Fig. 7A, B): eye region as far as constriction, punctured-reticulate; thoracic part finely sculptured, often poorly defined engraved reticulate; orange-brown, sometimes lighter in eye region; sparsely clothed with fine white hairs. *Eyes*: anteriors contiguous with apices procurved, fringed with whitish hairs. *Clypeus*: sparsely white haired. *Chelicerae* (Fig. 7C, D, E): engraved reticulate; yellow-brown, shiny; lateral keels brown-black with retrolateral and distal prolateral spurs; fang apophysis lacking. *Maxillae and Labium*: yellow-brown, labium sometimes darker. *Sternum* (Fig. 7L): light yellow-brown tinged with black. *Abdomen* (Fig. 7A, B): yellow-brown mottled with black; scuta orange-brown tinged with some black; sparsely clothed with short, fine whitish hairs with a poorly defined white haired spot on either side of constriction. *Legs*: femora I enlarged. Legs I dark brown but tarsi, tibiae distally, patellae, trochanters and coxae yellow-brown. Other legs yellow-brown tinged with some black on the sides. Ventral spination of legs I: metatarsi 2-2; tibiae 2-2-2-2 or 2-2-2-2-2; patellae 1 or 2. *Palp* (Fig. 7F, H, I, M): barbs usually distinct but sometimes separated by only a slight depression; tibiae with 3 blunt denticles, rarely 4.

*Dimensions*: total length 4.72-4.56 mm, carapace length 1.64-2.0 mm. *Ratios*: AM : AL : PM : PL : 9.5 : 6 : 1.5 : 5; AL-PM-PL: 7-7; a: 1.02-1.06, b: 0.98-1.01, c: 0.48-0.50, d: 0.33-0.44, e: 0.73-0.75 (7 ♂ examined).

**FEMALE.** *Carapace* (Fig. 7G): sculpturing and colour as in ♂. *Eyes*: anteriors contiguous with apices slightly procurved, fringed with whitish hairs. *Clypeus*: very sparsely fringed with long whitish hairs. *Chelicerae*: rugulose; light orange-brown, shiny; promargin with 4 or 5 teeth, retromargin with 6 or 7. *Maxillae and Labium*: pale orange-brown, *Sternum*: light orange-brown. *Abdomen*: dull yellowish mottled with black, with ill-defined orange-brown scuta; sparsely clothed with short, fine brownish hairs. *Legs*: more or less as in ♂. *Epigyne* (Fig. 7J, K): sometimes obscured by waxy secretions; the appearance of the secondary spermathecae is inconsistent and the opening shows some variation.

*Dimensions*: total length 4.36-5.0 mm, carapace length 1.64-2.04 mm. *Ratios*: AM : AL : PM : PL : 9.5 : 6 : 1.5 : 5, AL-PM-PL: 7-7; a: 1.02-1.04, b: 1.03-1.08, c: 0.49-0.52, e: 0.72-0.84 (10 ♀ examined).

**BIOLOGY.** Unknown.

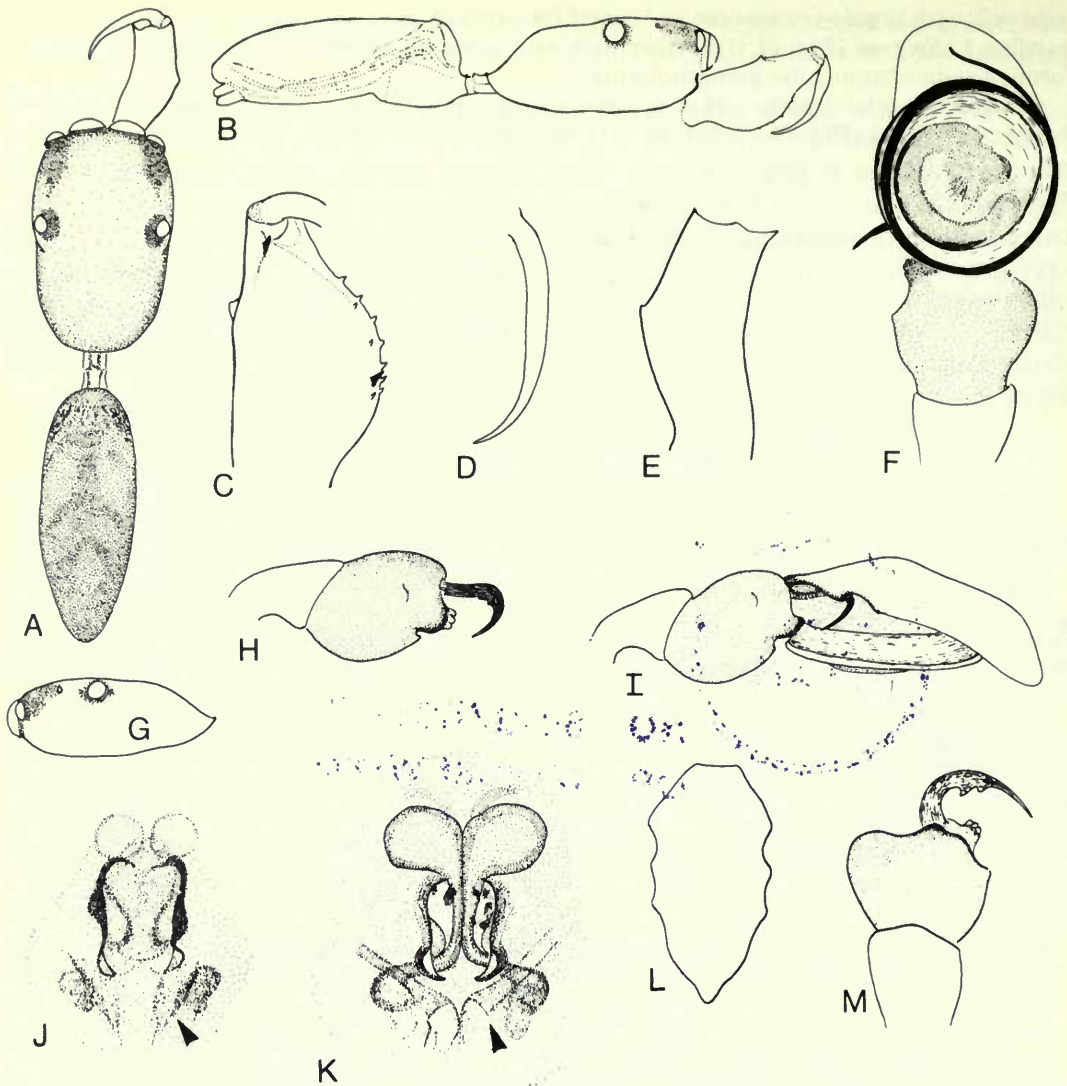

Fig. 7 *Belippo milloti* (Lessert). Lectotype ♂: (A) dorsal view; (B) lateral view; (C) chelicera, ventral view; (D) fang; (E) chelicera, dorsal view; (F) palp, ventral view; (H) palpal tibia, lateral view; (I) palp, lateral view; (L) sternum; (M) palpal tibia, dorsal view. ♀ from Zaire: (G) carapace, lateral view; (J) epigyne, ventral view; (K) vulva, ventral view.

#### DISTRIBUTION. Zaire.

MATERIAL EXAMINED. Lectotype ♂, data given in synonymy. Paralectotypes, 2♂, 4♀, data as for lectotype. ZAIRE: Kivu: Itombwe, Terr. Uvira, Poste Mulenge, Nyalengwe, 2300 m, in forest litter, 1♀, xi.1959 (*N. Leleup*, MT 114686); Itombwe, Terr. Uvira, 2700 m, litter in mountain forest with bamboo, 2♀, i.1960 (*N. Leleup*, B. 128); Itombwe, Terr. Mwenge, Lac Lungwe, litter in forest with bamboo, 1♂, viii.1953 (*N. Leleup*, MT 74873); Terr. Lubero, Cave Ribwe Lya Mikako, 1500 m, 1♂, 27.xii.1966 (*R. P. M. J. Celis*, MT 131344); Terr. Lubero, Kasuo, cave Kabwe-Ka-Ndongwe, 1450 m, 1♂, (*R. P. M. J. Celis*, MT 85488); Terr. Uvira, Haut Luvubu, 2750 m, 2♂, 1♀, v.1954 (*N. Leleup*, MT 78584-78587); Mt Lubwe, SE of Butembo, 2380 m, in mosses, 2♀, 13.iv.1971 (*R. P. M. Lejeune*, MT 138847); Itombwe, Terr. Uvira, Source



of the Nyalengwe, 2500 m, litter in mountain forest with bamboo, 1 ♀, vii.1959 (*N. Leleup*, MT 114209); Terr. Kabare, Mushuere, in litter, 1 ♀, 2.xi.1954 (*N. Leleup*, MT 80754); Itombwe, Terr. Uvira, Source of the Mugono, 2700 m, 2 ♀, i.1960 (*N. Leleup*, B. 127a); Kambaila, valley Kalingolingo, 1 ♂, vi.1973 (*M. Lejeune*, MT 145.836); Itombwe, Terr. Uvira, Source of the Kokololo, litter in mountain forest with bamboo, 1 ♂, i.1960 (*N. Leleup*, B. 123); Mt Lubwe, SE of Butembo, 2400 m, in mosses, 1 ♀, 13.iv.1971 (*R. P. M. Lejeune*, MT 138856); Dorsale of Lubero, Mt Muleke, 2300 m, 1 ♂, 1.vii.1963 (*R. P. M. J. Celis*, MT 125346); Butembo, 1 ♀, vi.1971 (*R. P. M. Lejeune*, MT 140.873); Itombwe, Terr. Mwenga, Source of the Bukundji, 2250 m, 1 ♀, ii.1957 (*N. Leleup*, MT 91632); Terr. Masisi, region of lake Mokoto, 1800 m, in

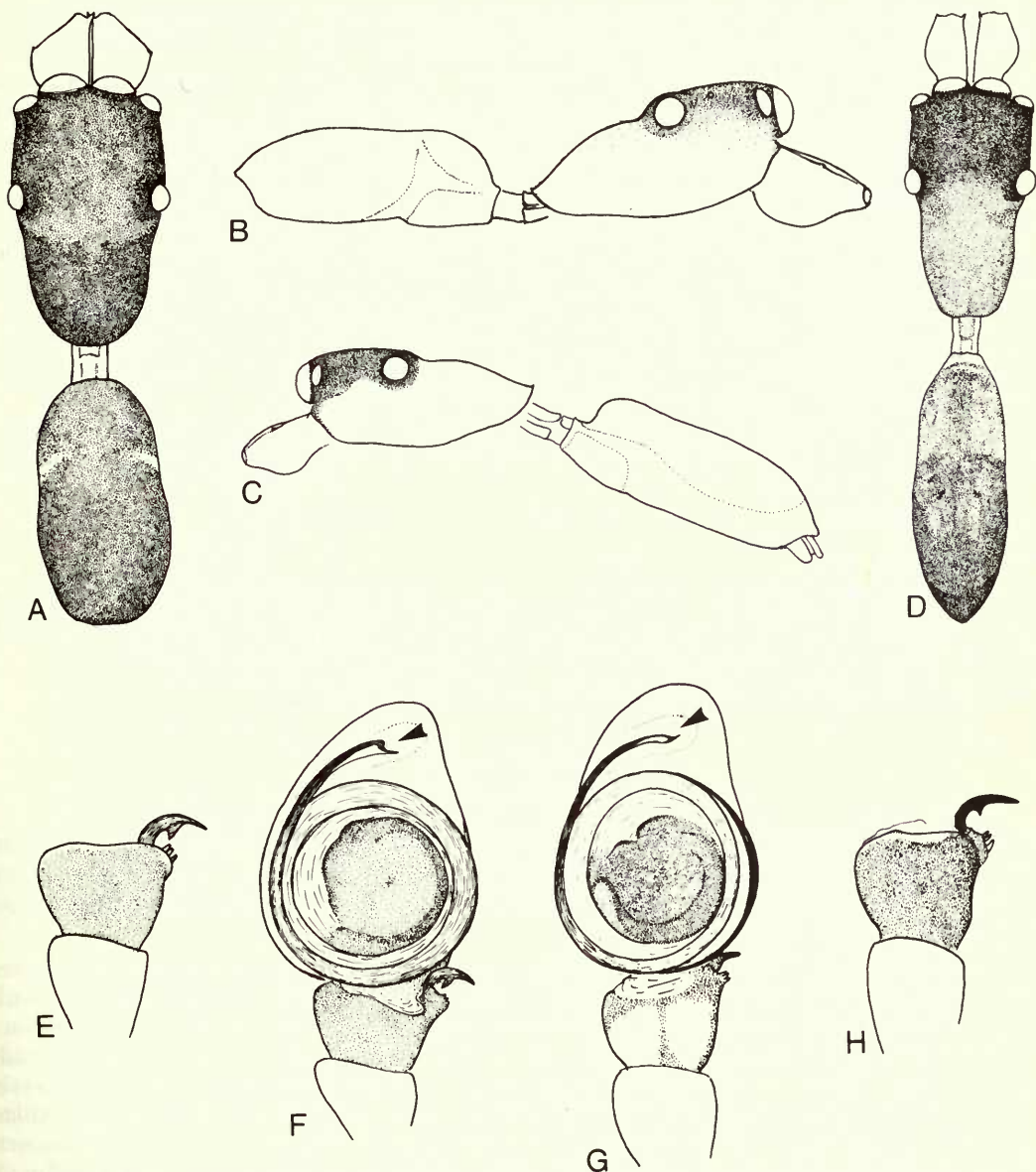

**Fig. 8** (A, B, E, F) *Belippo cygniformis* sp. n. Holotype ♂: (A) dorsal view; (B) lateral view; (E) palpal tibia, dorsal view; (F) palp, ventral view. (C, D, G, H) *Belippo ibadan* sp. n. Holotype ♂: (C) lateral view; (D) dorsal view; (G) palp, ventral view; (H) palpal tibia, dorsal view.

forest litter, 1 ♀, vi.1959 (*N. Leleup*, MT 114003); Volcan Karisimbi Rweru, 2700 m, 1 ♀ (*R. P. M. Lejeune*, MT 138.479) (all MRAC, Tervuren) Kivu, Kahuzi, in litter, 1 ♂, 8.xi.1953 (*A. B. Machado*, Ang. 10413.8) (BMNH). Note: all of these records are from the high Kivu Mountains.

*Belippo cygniformis* sp. n.

(Figs 8A, B, E, F; 9H–J; Pl. 2c)

DIAGNOSIS. *Belippo cygniformis* shows very close affinities to *B. ibadan* sp. n. but may be distinguished by the more robust body form (Fig. 8A) and swan-like embolic tip (Fig. 8F).

FEMALE. Unknown.

MALE. *Carapace* (Fig. 8A, B): eye region rugulose behind AL to punctured-reticulate with ripples between PL; thoracic part very densely papillate; orange-black with scattered white hairs, stout on lower part of thorax but grading to fine dorsally. *Eyes*: anteriors contiguous with apices slightly procurved, fringed with white hairs. *Clypeus*: sparsely fringed with long, fine white hairs. *Chelicerae* (Fig. 9I, J): very finely rugulose; dark orange-brown, rather shiny; lateral keels blackish with minute prolateral and distal retrolateral spurs; fang apophysis lacking. *Maxillae*: orange. *Labium*: orange-brown. *Sternum* (Fig. 9H): orange. *Abdomen* (Fig. 8A, B): dull yellow mottled with black; dorsal scuta contiguous dark mahogany, clothed with whitish hairs; ventral scutum elongate, orange-brown. *Legs*: femora I enlarged. Legs I mahogany but tarsi, metatarsi distally, patellae, distal femora, trochanters and coxae yellow-brown. Legs II yellow-brown but with blackish streak along inside of femora. Legs III brownish with tarsi, tibiae and femora proximally yellow-brown. Legs IV as III but trochanters and coxae yellow-brown. Ventral spination of legs I: metatarsi 2–2, tibiae 2–2–2–2, patellae 2. *Palp* (Fig. 8E, F): tibiae with 3 short, blunt denticles; tibial apophysis with single barb; embolic tip swan-like.

*Dimensions*: total length 3.88–4.16 mm, carapace length 1.92–1.96 mm. *Ratios*: AM : AL : PM : PL: 10 : 6 : 1 : 6, AL–PM–PL: 8–5; a: 1.03–1.04, b: 1.04, c: 0.48–0.50, d: 0.37–0.38, e: 0.73–0.78 (3 ♂ examined).

BIOLOGY. Unknown.

DISTRIBUTION. Ghana.

MATERIAL EXAMINED. Holotype ♂, GHANA: Kade, pyrethrum knockdown sample from the canopy of a plot of Amelonado cocoa, 13.vii.1971 (*J. D. Majer*) (BMNH, reg. no. 1977.4.21.31). Paratypes. GHANA: same locality and collector as holotype, 2 ♂, 1.xii.1971 (BMNH).

ETYMOLOGY. The specific name refers to the swan-like embolic tip.

*Belippo ibadan* sp. n.

(Figs 8C, D, G, H; 9A–G; Pls 1g; 2d)

DIAGNOSIS. *Belippo ibadan* is very closely related to *B. cygniformis* sp. n. Males are distinguished by the more slender body form (Fig. 8D) and the shape of the embolic tip (Fig. 8G). Females are characterized by the structure of the epigyne (Fig. 9C, D) and the densely papillate thorax (note female *cygniformis* are unknown).

MALE. *Carapace* (Fig. 8C, D; Pl. 2d): eye region rugulose to punctured-reticulate with ripples between PL, thoracic part moderately papillate (rather difficult to see); eye region blackish with thorax and sides orange-brown; very sparsely covered with fine, light brown hairs. *Eyes*: anteriors contiguous with apices procurved, fringed with whitish hairs. *Clypeus*: sparsely white haired. *Chelicerae* (Fig. 9E, F): finely rugulose; dark brown with glistening reflections, lateral keels blackish with minute prolateral and distal retrolateral spurs; fang apophysis lacking. *Maxillae and Labium*: orange-brown. *Sternum* (Fig. 9G): yellow-orange with darker margins. *Abdomen* (Fig. 8C, D; Pl. 1g): dull yellow mottled with black; dorsal scuta contiguous, orange suffused with black, the posterior two-thirds dark mahogany; ventral scutum orange-brown; very sparsely covered with fine hairs. *Legs*: femora I enlarged. Legs I yellowish orange but tibiae distally and metatarsi proximally blackish, femora dark mahogany with distal part whitish yellow. Legs II pale



yellowish orange. Legs III–IV pale yellowish orange with light greyish mottling except on tarsi. Ventral spination of legs I: metatarsi 2–2, tibiae 2–2–2–2, patellae 2. *Palp* (Fig. 8G, H): tibia with 3 small denticles; tibial apophysis with single barb; embolus slightly broadened distally with tip drawn to a point.

*Dimensions*: total length 4.4–4.48 mm, carapace length 1.96–2.08 mm. *Ratios*: AM : AL : PM : PL : 10 : 6 : 1.3 : 6, AL–PM–PL: 7.5–5.5; a: 1.02–1.03, b: 1.05–1.07, c: 0.45–0.46, d: 0.26–0.28, e: 0.74–0.77 (4♂ examined).

**FEMALE.** *Carapace* (Fig. 9A, B): eye region rugose with rippling between PL; thoracic part densely papillate; dark orange-brown, a shade lighter between PL and in constriction; very sparsely covered with fine white hairs on thorax (more or less rubbed in specimens at hand). *Eyes*: anteriors contiguous with apices slightly procurved, fringed with white hairs. *Clypeus* as in ♂. *Chelicerae*: finely rugulose; orange-brown; promargin with 4 teeth, retromargin with 7.

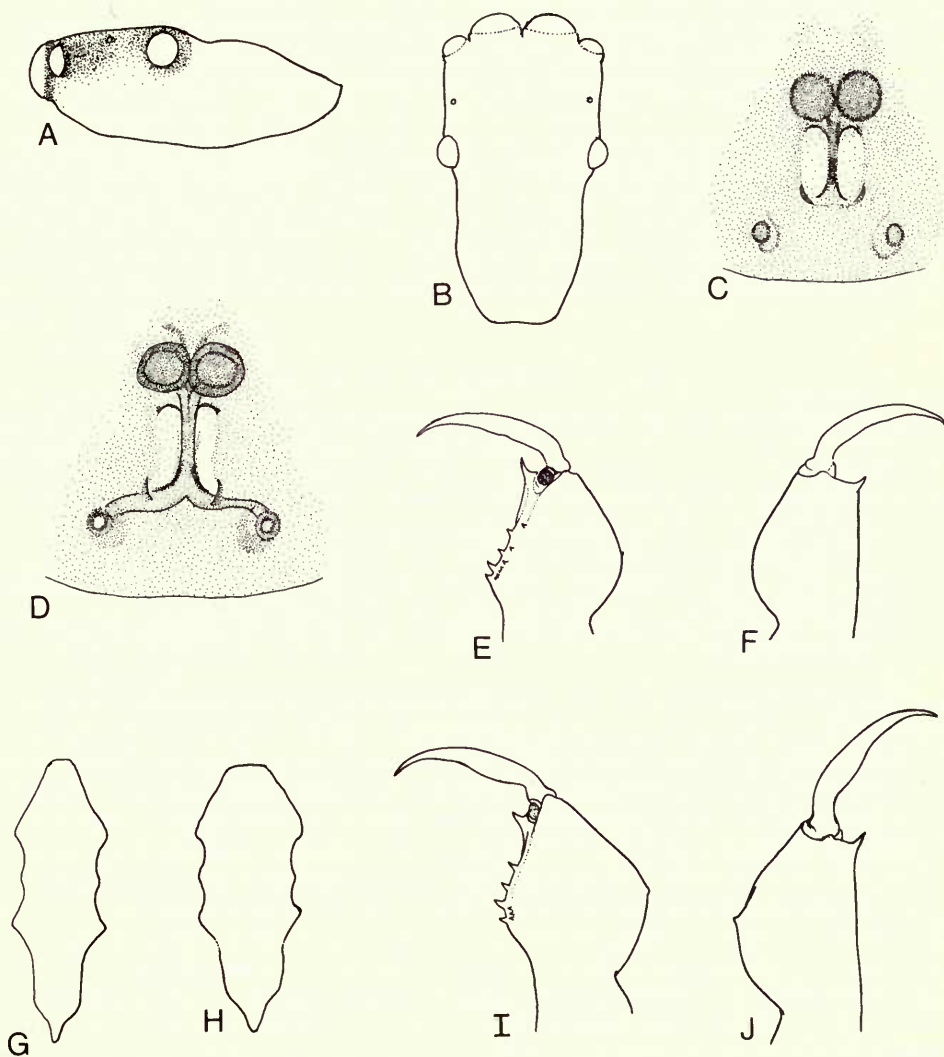

**Fig. 9** (A–G) *Belippo ibadan* sp. n. Paratype ♀: (A) carapace lateral view; (B) dorsal view; (C) epigyne, ventral view; (D) vulva, ventral view. Holotype ♂: (E) chelicera, ventral view; (F) chelicera, dorsal view; (G) sternum. (H–J) *Belippo cygniformis* sp. n. Holotype ♂: (H) sternum; (I) chelicera, ventral view; (J) chelicera, dorsal view.

*Maxillae and Labium*: as in ♂. *Sternum*: light orange-brown. *Abdomen*: dull yellowish tinged with grey with ill-defined orange-brown scuta and 2 pairs of impressed dots; sparsely clothed with fine hairs with scanty white haired band in area of constriction. *Legs*: femora I enlarged. Legs I with tarsi and metatarsi distally yellow-brown; metatarsi proximally and tibiae dark brownish orange; patella orange-brown; femora orange-brown but with distal third, trochanters and coxae whitish yellow. Legs II yellow-brown with tarsi paler, coxae dark brownish orange and trochanters light yellowish. Legs III dark brown with tarsi light yellow brown. Legs IV as III but with tibiae distally and patellae proximally pale yellowish. Ventral spination as in ♂. *Epigyne* (Fig. 9C, D): opening sometimes clogged with waxy secretion; 'tail' of secondary spermathecae not always visible.

*Dimensions*: total length 4.90–5.48 mm, carapace length 2.24–2.28 mm. *Ratios*: AM : AL : PM : PL : 10 : 5.5 : 1.6 : 6, AL–PM–PL : 7–6; a : 1.02–1.04, b : 0.92–1.11, c : 0.46–0.48, e : 0.74–0.77 (4♀ examined).

**BIOLOGY.** Mr A. Russell-Smith found that this species was quite abundant on the ground in riverine woodland at the beginning of the wet season (March to May) where it was particularly conspicuous beneath bamboos, running about in litter with several species of ant, *Mesoponera ambigua* and *Anochetus bequaerti* in the Ponerinae and *Crematogaster depressa* in the Myrmicinae.

**DISTRIBUTION.** Nigeria.

**MATERIAL EXAMINED.** Holotype ♂, NIGERIA, Ibadan, International Institute of Tropical Agriculture, riverine woodland, 21.iv.1974 (*A. Russell-Smith*) (BMNH, reg. no. 1975.1.31.16). Paratypes. NIGERIA: same data as holotype, 1♂, 1♀ (BMNH); same locality and collector as holotype, 2♂, 2♀, 23.iii.1974; 1♀, 5.v.1974 (BMNH).

**ETYMOLOGY.** The specific name is a noun in apposition taken from the type-locality.

### Genus *MYRMARACHNE* Macleay

*Myrmarachne* Macleay, 1838 : 10. Type-species *Myrmarachne melanocephala* Macleay, by monotypy.

Simon, 1901 : 504. Roewer, 1954 : 950. Bonnet, 1957 : 2997. Roewer, 1965 : 33. Galiano, 1969 : 107.

*Hermosa* Peckham & Peckham, 1892 : 53. Type-species *Hermosa volatilis* Peckham & Peckham, by monotypy. [Synonymized by Simon, 1901 : 504.] Bonnet, 1957 : 3014. Roewer, 1965 : 64.

*Iola* Peckham & Peckham, 1892 : 75. Type-species *Iola cowanii* Peckham & Peckham, by monotypy. [Synonymized by Simon 1901 : 504.] Bonnet, 1957 : 2298. Roewer, 1965 : 65.

*Bizone* Simon, 1903 : 1050. Type-species *Bizone longiventris* Simon, by original designation. [Junior homonym of *Bizone* Walker, 1854.] Bonnet, 1957 : 887. Roewer, 1965 : 79.

*Bizonella* Strand, 1929 : 15. [Replacement name for *Bizone* Simon non Walker.] Bonnet, 1957 : 887. Roewer, 1965 : 79. **Syn. n.**

The problems of classification in the Salticidae have been discussed by Petrunkevitch (1928), Prószyński (1971a, 1971c) and Jackowska & Prószyński (1975). In the system proposed by Simon (1901) and modified by Petrunkevitch (1928) the Salticidae are grouped in 22 subfamilies, some of which include ant-like genera. *Myrmarachne* is the type-genus of the subfamily Myrmarachninae but Prószyński (1971a) has suggested that all ant-like Salticidae should be placed in one subfamily, the Synemosyninae Banks, on the grounds that all, or at least the majority, of ant-like salticid genera are of monophyletic origin. Selection for ant mimicry results in convergence and specialization; the possession of ant-like characters does not necessarily indicate a phylogenetic relationship. Ant mimicry is fairly common in spiders and has arisen many times, at least four times in the Clubionidae and several times in the Theridiidae, Araneidae and Thomisidae and also in the Gnaphosidae, Zodariidae and Eresidae (Reiskind & Levi, 1967). The Salticidae are no exception although the relationship between ant-like and non ant-like genera is poorly known. Ant-like forms may have evolved at least three or four times in Africa alone, since the genera *Myrmarachne*, *Enoplomischus*, *Cosmophasis* and *Belippo* each appear to represent monophyletic groups. *Cosmophasis* species are behavioural ant-mimics and Simon (1901) has in my view correctly placed this genus in his suprageneric group Chrysilaeae, which includes mimetic and non mimetic genera that show affinities in the structure of the genitalia.



**DEFINITION.** Ant-like spiders ranging from about 3.0 to 9.0 mm in length. Males sexually dimorphic. *Carapace*: shape variable, usually constricted with lateral wedge-shaped patches of whitish hairs and one or two pairs of dorsal trichobothria; sculpturing variable; colour patterns usually lacking, rarely hirsute. *Eyes*: anterior row subcontiguous or contiguous with apices procurved or level in frontal view; middle row midway or nearly midway between anterior lateral and posterior lateral eyes; posterior row equal to or wider than anterior row; quadrangle length between 27 and 44 per cent of carapace length. *Clypeus*: very low. *Female chelicerae*: normal with 4–7 promarginal and 5–8 retromarginal teeth. *Male chelicerae*: strongly developed, usually elongate and more or less horizontal; spurs present or absent; fang usually sinuous, apophysis present or absent; teeth usually numerous, rarely lacking on retromargin. *Maxillae*: elongate, subparallel or slightly divergent. *Labium*: elongate, rarely with median keel. *Sternum*: shape variable, usually elongate, sometimes very narrow. *Pedichel*: elongate, segments usually subequal. *Abdomen*: shape variable, constriction present or absent, sometimes reinforced with scanty band of hairs; scuta present in males, lacking or vestigial in females. *Legs*: usually slender, femora I sometimes dorsoventrally enlarged and slightly compressed laterally; formula 4132; spination: lateral spines absent; dorsal spines sometimes present on femora; ventral spines present on legs I and II but usually absent on legs III and IV; claw tufts present but scopula lacking. *Female palp*: palette-shaped, fringed with preening setae. *Male palp* (Fig. 3D, F): tibial apophysis with or without hook; flange present or absent; embolus long and slender with two turns around tegulum, rarely distally filamentous; tegulum subcircular with small to large seminal reservoir; pars pendula present but conductor and median apophysis lacking; cymbium with proximal ectal margin sometimes protuberant or depressed with setae. *Epigyne* (Fig. 3E): comparatively simple with indistinct openings separated by ill-defined septum; paired lateral pouches or median subtriangular pouch present; spermathecae simple, looped or twisted, rarely coiled, not distinctly separated from proximal seminal ducts; distal seminal ducts usually indistinct, sometimes broad and obscurely convoluted, rarely spiralled.

**DIAGNOSIS.** *Myrmarachne* is separated from *Belippo* by the absence of a movable tibial apophysis on the male palp and lack of secondary spermathecae in females. As with *Belippo* a fuller diagnosis cannot be given until related genera have been revised.

**SPECIES GROUPS.** The genus *Myrmarachne* includes, at present, 58 species in the Ethiopian region which are arranged here in species groups or treated as species sola, i.e. species which cannot at the present time be attributed to any of the species groups. The use of species groups is particularly useful when they are based on the fauna of a restricted region as is the case here but it is not suggested that they are entirely natural as the larger groups may have been affected by parallel evolution. Clearly the status of the groups will have to be revised when the large and important oriental fauna is studied.

The groups are based mainly on genitalic characters. In the male they are: the form of the tibial apophysis, the presence or absence of a hook; the presence or absence of a flange; the presence or absence of depressions or protuberances on the proximal ectal margin of the cymbium; the form of the embolus and seminal reservoir in the tegulum. In the female: the presence of a median or paired lateral pouches, the form of the spermathecae and the nature of the distal seminal ducts. The presence of a distal lobe on the lower margin of some male chelicerae is the only non-genitalic character which comes into consideration.

Two groups are known only in one sex. Males of the African *lesserti*-group have distinctive palps with an unusually long apophysis and pronounced flange. Females of the Madagascan *nubilis*-group have distinctive epigynes with unusually coiled spermathecae and poorly defined distal seminal ducts. The two groups are not closely related but it is likely that one or two of the Madagascan males treated as species sola may belong in the *nubilis*-group.

In the *electrica*-group from Madagascar the long filamentous embolus of the male palp and coiled distal seminal ducts in the epigyne are possibly primitive, plesiomorphic forms. The group includes some rather different looking species one of which, *M. eugenei* nom. n., was originally described in *Emertonius*.

The *volatilis*-group found in Africa and Madagascar also includes some peculiar looking species

and one of them, *M. longiventris* (Simon), is the type of the genus *Bizone*. Males are characterized by a distal lobe on the lower margin of the chelicerae and a large seminal reservoir in the tegulum. Females have a median pouch and very simple spermathecae. In body form the group shows some resemblance to *Belippo*.

There seems to be a general correlation between the development of pouches in females (i.e. single median or paired lateral) and the form of the tibial apophysis in males. Females of the large African *tristis*-group have paired lateral pouches and males a hooked tibial apophysis which is protected by a fringed depression in the cymbium. On the other hand, the smaller, mainly African *formicaria*-group is characterized by a median pouch in females but in males the tibial apophysis is not hooked and the fringed proximal depression is lacking or very poorly developed. It is evident that the *tristis* and *formicaria*-groups are closely related as they appear to be linked by several intermediate species (e.g. *M. eidmani* Roewer, *M. giltayi* Roewer, *M. luachimo* sp. n., *M. mussungue* sp. n. and *M. natalica* Lessert). In females, the lateral pouches are more or less contiguous and positioned medially; in males, the tibial apophysis is not hooked but the proximal depression is retained. Provisional studies show that the *tristis* and *formicaria*-groups are represented in the Palaearctic and Oriental regions and suggest that it may still be useful to retain these groups in a wider context.

Of more interest is the occurrence of the *volatilis*-group in the Oriental and Australasian regions and its affinities with the Neotropical fauna. In general, the known South American species could be arranged in two groups, if based on the male genitalia, but form one group if based on the female. The epigyne structures (Galiano, 1969, 1974) are very similar to those in the *volatilis*-group but the male palps are somewhat different and do not fall within the present concept of the *volatilis*-group. However, it would be premature to reach any firm conclusions at the present time until the Oriental and Australasian fauna is better known.

VARIATION. Madagascan species are usually more easily identified than African because the genitalia are more diverse and distinct. Most African species belong to the *tristis* and *formicaria*-groups which are characterized by the rather homogeneous genitalia. Females of both groups can be difficult to determine as the epigynes are often poorly defined and variable in appearance. In some cases it may be difficult to decide if the epigyne has median or paired lateral pouches. The median pouch is often pale but can normally be recognized with a good dissecting microscope. The lateral pouches can also be difficult to distinguish and in some cases it may be necessary to prepare temporary lactic-acid mounts for examination with the compound microscope. Unfortunately there are apparently no other characters which can be used to place females in their appropriate groups and circumstances will occur in which females cannot be identified in the absence of males.

O. Pickard-Cambridge (1869) was probably the first to draw attention to the wide variations in size and colour of *M. plataleoides* in Ceylon. Peckham & Peckham (1892) quoted O. Pickard-Cambridge but Szombathy (1913) figured several forms of *M. plataleoides* in an important paper that seems to have been overlooked by later workers. The failure to recognize such variants has resulted in numerous synonyms and caused many difficulties during this study. The realization that leg spination and cheliceral dentation showed intraspecific variation and that carapace shape, eye position and cheliceral form and length were allometric growth characters has substantially altered the species concept in *Myrmarachne*. In some cases (e.g. *M. elongata*, Figs 25, 26) extreme size variation would appear to be continuous but in others (e.g. *M. ichneumon* Simon Fig. 31A, B) intermediate forms are lacking. However, the occurrence of polytypic species can only be determined when adequate samples have been investigated and the discontinuities in collecting have been eliminated.

*M. plataleoides*, *M. foenisex* Simon and *M. kiboschensis* Lessert all show distinct colour differences in life but in the majority of species colour variation is only known from preserved specimens. The effect of postmortem changes is sometimes considerable and it may well be the case that many *Myrmarachne* are blackish in life and that the predominantly yellow-brown colour of preserved specimens is due to the loss of black pigment, a factor which must be taken into account when identifying fresh material. Similarly, preservation may result in bloated or shrunken abdomens considerably altering the general appearance of the specimen.



The problems that arise from intraspecific variation are by no means unique to *Myrmarachne* and the effects of postmortem changes might well apply to any spider but in *Myrmarachne* both have caused much difficulty since the structure of the genitalia cannot always be relied upon to separate the species. Obviously the genitalia are of prime importance but within the species groups they are homogeneous and can be intraspecifically variable. Differences in the form of the tibial apophysis, the relative size of the palpal tibia and spermathecae configuration can be difficult to interpret in the absence of a good series of specimens. Each species has to be considered in the context of all its attributes but even so it is inevitable that intermediates will occur and some apparently good species may eventually have to be placed in synonymy.

**BIOLOGY.** Although a few elongate, slender forms of *Myrmarachne* could be mistaken for reed or stem mimics (e.g. *M. foreli* Lessert), the majority of species are ant-like in appearance and are considered to be ant mimics in spite of the fact that the majority of species have no known models. The range of ant mimicry shown by *Myrmarachne* varies from species-specific to generalized (i.e. no single species of model can be designated). At present only two distinctive species of *Myrmarachne* can be properly described as specific ant mimics. *M. plataleoides* (O. P.-Cambridge) mimics the Indian weaver ant *Oecophylla smaragdina* (Fabr.) and *M. foenisex* Simon mimics the African weaver ant *O. longinoda* (Lat.). The ants are closely related but *M. plataleoides* does not apparently show any marked affinities with Ethiopian *Myrmarachne* and similarities with *M. foenisex* are probably the result of convergence. Several other *Myrmarachne* (e.g. *M. collarti* Roewer, *M. elongata* Szombathy and *M. foreli*) have been associated with specific ants but it is not known for certain that the ants represent specific models. Unfortunately, most species of *Myrmarachne* are not distinctive and models cannot be casually associated in the field especially where isopatric species are concerned. Most generalized mimics are therefore species which are poorly known and those which have been collected with several species of ant. Some of these generalized mimics will eventually qualify as specific mimics but most will probably prove to be mimics of ants at a generic level or even ants of a particular size range and colour. A list of the spiders, *Belippo* and *Myrmarachne*, and associated ants is given below. The list is believed to be complete for the Ethiopian region and for the Oriental species *M. plataleoides*.

**Table 1** List of mimics and their models or potential models

<i>Belippo calcarata</i>	<i>Pheidole</i> sp.
<i>B. ibadan</i>	<i>Mesoponera ambigua</i> ; <i>Anochetus bequaerti</i> ; <i>Crematogaster depressa</i>
<i>Myrmarachne collarti</i>	<i>Odontomachus troglodytes</i>
<i>M. elongata</i>	<i>Tetraoponera anthracina</i>
<i>M. dundoensis</i>	<i>Camponotus</i> sp.
<i>M. foenisex</i>	<i>Oecophylla longinoda</i>
<i>M. foreli</i>	<i>Tetraoponera natalensis</i>
<i>M. inflatipalpis</i>	<i>Crematogaster</i> sp.
<i>M. insulana</i>	<i>Tetramorium</i> sp.
<i>M. kiboschensis</i>	<i>Camponotus</i> sp., <i>vetitus</i> -group; <i>Odontomachus troglodytes</i>
<i>M. legon</i>	<i>Camponotus acvapimensis</i> ; <i>Crematogaster</i> sp.
<i>M. marshalli</i>	<i>Camponotus</i> spp.
<i>M. nigeriensis</i>	<i>Camponotus</i> sp.
<i>M. plataleoides</i>	<i>Anoplolepis longipes</i> ; <i>Oecophylla longinoda</i> ; <i>Plagiolepis</i> sp.; <i>Prenolepis</i> sp.; <i>Solenopsis</i> sp.; <i>Solenopsis geminata</i>
<i>M. uwira</i>	<i>Camponotus sericeus</i>

*Myrmarachne* resemble ants in body form, the carapace is usually constricted and joined to the abdomen by a distinct waist, the pedicel. In many cases the constriction is apparently deepened by a wedge-shaped band of whitish hairs on each side. Most species are cryptically coloured and dark hues are prominent. The degree of morphological similarity between *Myrmarachne* and its models is close and would appear to equal that found in other ant-like spiders, particularly in the Clubionidae. The resemblance, however, is not perfect for the best morphological ant mimics are to be found in the Insecta especially amongst the mirid bugs.



Most species are active during the day and are found in association with ants; sometimes several species of ant and *Myrmarachne* can be found in the same habitat. The characteristic behaviour of ants is successfully mimicked by *Myrmarachne* and the movements and postures are copied to a remarkable degree. The position and movement of the first pair of legs mimic an ant's antennae and a number of species will reflex the abdomen and assume a defensive posture when alarmed. Behavioural mimicry has been developed even further by *M. foenisex* which is reported to tend coccids and imbibe the honey-dew (Collart, 1929a, 1929b).

Some species are arboreal (e.g. *M. foenisex* and *M. platalooides*) but the majority are probably terrestrial and live in litter and the lower vegetation zones. At rest or during periods of inactivity, *Myrmarachne* (like other non ant-like salticids) remain in silken retreats and are safe from the foraging activities of ants. However, the behaviour patterns of *Myrmarachne* do not apparently deceive the ants for *M. platalooides* (Mathew, 1954) and *M. foenisex* (Collart, 1929a, 1929b) are very careful to avoid direct contact with the ants which will normally attack if the opportunity arises. Edmunds (1974) reports an instance when *O. longinoda* was found eating the eggs of *M. foenisex* whilst the spiders waited a few centimetres away and made no attempt to defend them. On the other hand, Marson & Carpenter (1946) and Marson (1947) report that males of *M. platalooides* will chase away *O. smaragdina*.

Most *Myrmarachne* are probably Batesian mimics since the so-called innocuous spider gains protection by its likeness to a pugnacious model, the ant; however, no *Myrmarachne* is known to fulfil all the requirements for Batesian mimicry listed by Rettenmeyer (1970). The field observations of Marson & Carpenter (1946), Mathew (1954) and Edmunds (1974) suggest that *Myrmarachne* are not aggressive mimics and do not feed on their models, although Hingston (1927) reports an unnamed *Myrmarachne* stalking ants. The food preferences of *Myrmarachne* are not well known but *M. platalooides* will feed on small Diptera and Hemiptera (Bhattacharya, 1939; Marson, 1946), and ant larvae (Mathew, 1954). Collart (1941) and Mathew (1954) have reported the occurrence of *Myrmarachne* in the active nests of *Oecophylla* but both authors were convinced that this happened only under certain conditions. However, subsequent reports (Mr B. Bolton, Ms J. Lee and Dr A. B. Machado, unpublished observations) suggest that *M. foenisex* often occurs in active nests and regularly feeds on ant larvae. Even Mathew (1954) reports that his attempts to rear spiderlings of *M. platalooides* on an exclusive diet of ant larvae were 'quite a success and it is especially noteworthy that the specimens continued to be healthy and vigorous through all stages'.

Courtship of *M. platalooides* has been described by Mathew (1940). In the natural state males do not indulge in courtship dances but pair with the female inside her nest. If the female is subadult the male will wait outside the chamber and pair when the female has moulted. In captivity the male will court the female but the preliminary movements are the same as those made by the male when he comes across any stranger. In *M. foenisex* (Collart, 1941) and *M. legon* sp. n. (M J. L. Ledroux, pers. comm.) there is apparently no courtship before pairing but males of *M. wira* sp. n. and *M. kiboschensis* will perform courtship dances in captivity and posture in the presence of other *Myrmarachne* and occasionally in the absence of any apparent stimulus (Wanless, unpublished observations). Males would appear to mate several times and the females accept several mates.

*Myrmarachne* lays on average 20–25 eggs which are guarded by the female. They are usually laid in two batches so that developing eggs and embryos may be found in the same cocoon. Cocoons normally occur singly but in *M. platalooides* several are sometimes aggregated on a single leaf (Mathew, 1954). Collart (1929a) also reports gregarious behaviour in female *M. foenisex* at the time of egg-laying. According to Mathew (1954) the eggs of *M. platalooides* hatch in about a week; the spiderlings mature after six moults and mimic several species of ant during their development. The embryos break free of the chorion, moult twice within the cocoon (i.e. first and second instars) but do not feed. The spiderlings leave the nest as second instars; they are elongate, ant-like in form and movement and resemble dark brown (*Prenolepis*) and to a lesser extent small black Dolichoderinae ants. Third instars are variable in colour, some retain the dark coloration of the previous stage while others are reddish yellow, the posterior half of the abdomen alone retaining the dark colour and as such closely resemble small stinging (*Solenopsis*)

ants. Fourth instars show a tendency to become light in colour and resemble *Plagiolepis* ants. Fifth instars mimic *Oecophylla*. Sixth instars achieve adult form and the male is distinguished by the horizontally extended chelicerae.

In a less detailed account, Bhattacharya (1939) reports that *M. plataleoides* lays 8–12 eggs and reaches maturity in six moults (i.e. eight if one includes two moults in the cocoon, not counted by Bhattacharya) and mimics *Solenopsis geminata* (Fabr.) and *Anoplolepis longipes* (Jerd.) during its development.

The phenomenon of transformational mimicry has not been described in other *Myrmarachne* but it has been demonstrated in *Castianeira rica* Reiskind, a clubionid ant-mimic. Reiskind (1970) has shown by comparison with a congeneric, non-mimetic control species that multiple mimetic forms of *C. rica* were the result of (i) sexual dimorphism, (ii) colour variation in the adult female and (iii) development changes in the preadult instars. The multiple mimicry in *C. rica* contains at least five forms: two from sexual dimorphism, one from colour variation in the female and at least two or more from transformational mimicry (i.e. *C. rica* instars II and III mimic small myrmicine ants; instars IV and V resemble medium-sized attine ants). In *Myrmarachne* sexual dimorphism is always present and transformational mimicry may well occur in the majority of species. In some species (e.g. *M. plataleoides*, *M. foenisex* and *M. marshalli*) intraspecific variation particularly in the male may account for several mimetic forms.

By mimicking ants *Myrmarachne* gain protection from many spider predators and probably avoid many ant predators by their habit of running away when alarmed (Mathew, 1934), but it has yet to be demonstrated that mimicry has resulted in the lowering of the fecundity rate as suggested by Peckham (1889) for North American ant-like salticids. Edmunds (1974) has shown that *Myrmarachne* does in fact gain some protection from hunting wasps. Many wasps prey on spiders to provide food for their larvae. Most belong in the families Pompilidae and Sphecidae. All pompilids attack spiders and provide a single spider for each larva. In the Sphecidae there are only three groups which attack spiders. The Miscophini in the Larrinae are similar to pompilids in that they are single provisioners but *Sceliphron*, *Hemichalybion*, *Pison* and *Trypoxylon* in the Trypoxyloninae are multiple provisioners and build cells which are often crammed with spiders. The destruction of spiders by these wasps has been graphically described by Peckham & Peckham (1895) (quoted by Pocock, 1909) and it is evident that hunting wasps must be regarded as a major predator and possibly as a selective agent for ant mimicry, as none of the above sphecids or pompilids are known to attack ants. The majority of *Myrmarachne* which have been found in wasp nests were taken by *Pison* or *Trypoxylon* wasps. A nest of *Trypoxylon placidum* Cameron from Malaya contained 10 *Myrmarachne* of various species, 4 other salticids and 3 other spiders (Richards, 1947). Two *Pison* cells from Ghana contained 1 male (*M. richardsi* sp. n.), 6 females of *M. legon* sp. n., 20 immature *Myrmarachne* and 14 other juvenile Salticidae. The predatory behaviour of sphecid wasps has been studied by Dr M. Edmunds (unpublished data) and preliminary results show that immatures and female *M. elongata* Szombathy are heavily preyed upon and are found in the majority of nests. Other salticid genera also attacked by wasps include *Pseudicus*, *Telamonia* and *Cosmophasis*. It is of interest to note that *Cosmophasis* is a genus of behavioural ant-mimics which feeds on ants (Wanless, unpublished data) and is one of the few cases of aggressive mimicry known in the Salticidae.

**DISTRIBUTION IN THE ETHIOPIAN REGION.** At present the African fauna is represented by 44 species and includes the *tristis* and *lesserti*-groups, most of the *formicaria*-group and part of the *volatilis*-group. Madagascar is represented by 14 endemics which include the *nubilis* and *electrica*-groups, 6 species *Sola*, part of the *volatilis*-group and one member of the *formicaria*-group. *Myrmarachne* also occurs on São Thomé and Fernando Po but is apparently absent from Aldabra, the Comoro and Mascarene Islands. The Seychelles are represented by *M. constricta* (Blackwall) and several other ant-like salticids which will be described elsewhere.

### Key to species of *Myrmarachne* in the Ethiopian Region

#### Males

- 1 Pedicel exceedingly long, anterior segments nearly 10 times length of posterior one (Fig. 73A).  
 (Madagascar) . . . . . *eumenes* (Simon) (p. 114)



-	Pedicle otherwise . . . . .	2
2	Labium with well-developed median keel (Fig. 84D). (Madagascar) . . . . .	3
-	Median keel lacking or very rarely weakly developed . . . . .	4
3	Flange strongly developed, fringed with long setae (Fig. 82C-E)	
	<i>simplexella</i> Peckham & Peckham (p. 121)	
-	Flange very weakly developed, fringed with short setae (Fig. 84E) . . . . .	<i>diegoensis</i> sp. n. (p. 125)
4	Chelicerae with paired prolateral spurs (Fig. 70C); flange reduced to small lobe (Fig. 70F). (Madagascar) . . . . .	<i>augusta</i> Peckham & Peckham (p. 109)
-	Chelicerae and flange otherwise . . . . .	5
5	Embolus distally thread-like (Figs 76A; 78E, B; 80A); cymbium more bulbous distally (Figs 76D; 78B; 80B). (Madagascar) . . . . .	6
-	Embolus distally slender, cymbium less bulbous distally . . . . .	8
6	Thoracic part irregularly tumulose (Pl. 2e, f) with a precipitous slope (Fig. 75F)	
	<i>eugenei</i> nom. n. (p. 115)	
-	Thoracic part otherwise . . . . .	7
7	Seminal reservoir proximal and procurved, embolus with 3 turns around tegulum (Fig. 78E)	
	<i>electrica</i> Peckham & Peckham (p. 118)	
-	Seminal reservoir distal and recurved, embolus with 2 turns (Fig. 80A) . . . . .	<i>peckhumi</i> Roewer (p. 119)
8	Proximal ectal margin of cymbium protuberant, tibial apophysis long with flange arising from ventral margin (Fig. 69A-D). (South Africa) . . . . .	9
-	Not with the combination of characters given above . . . . .	10
9	Chelicerae with retrolateral spurs (Figs 68A; 69E); embolus slender (Fig. 69A)	
	<i>lesserti</i> Lawrence (p. 106)	
-	Retrolateral spurs lacking; embolus distally broad, tapering to fine point (Fig. 69D)	
	<i>albasetosa</i> sp. n. (p. 108)	
10	Chelicerae club-shaped (Figs 17A; 23A; 24A) . . . . .	11
-	Chelicerae otherwise . . . . .	13
11	Tibial apophysis hooked (Fig. 23F; 24B) . . . . .	12
-	Tibial apophysis sigmoid (Fig. 17B) . . . . .	<i>idmani</i> Roewer (p. 39)
12	Flange large in lateral view (Fig. 23F). (Angola, São Thomé) . . . . .	<i>confusus</i> sp. n. (p. 46)
-	Flange small in lateral view (Fig. 24B). (Uganda, Zaire) . . . . .	<i>collarti</i> Roewer (p. 49)
13	Tibial apophysis hooked (Figs 11G; 22D-G; 28B; 35F) . . . . .	14
-	Tibial apophysis otherwise (Figs 15F, G, H; 45F; 47B-D; 60A, B) . . . . .	29
14	Body form as in Fig. 33A, F. (West and Central Africa) . . . . .	<i>foenisex</i> Simon (p. 60)
-	Body form otherwise . . . . .	15
15	Carapace as in Fig. 35A, G, thoracic part long. (Ghana) . . . . .	<i>richardsi</i> sp. n. (p. 61)
-	Carapace and thoracic part otherwise . . . . .	16
16	Thorax fawnish red with brown submarginal bands on the sides (Fig. 30A). (Senegal)	
	<i>rufisquei</i> Berland & Millot (p. 55)	
-	Thorax otherwise . . . . .	17
17	Abdomen slender, elongate with little white haired tufts in shallow constriction (Fig. 20B, C); tibial apophysis and flange well developed (Fig. 22E, G). (Kenya) . . . . .	<i>naro</i> sp. n. (p. 43)
-	Not with combination of characters given above . . . . .	18
18	Abdomen very long and slender (Fig. 20A, D, E); flange of tibial apophysis set medially on tibia (Fig. 22A, C) . . . . .	19
-	Not with combination of characters given above . . . . .	20
19	Flange large in lateral view (Fig. 22F). (Ivory Coast, Ghana) . . . . .	<i>hesperia</i> (Simon) (p. 46)
-	Flange small in lateral view (Fig. 22D). (Zaire) . . . . .	<i>evidens</i> Roewer (p. 42)
20	More robust species with heavy chelicerae, widest medially (Figs 10A; 12A); flange broadly produced, partly obscuring small tibial apophysis (Fig. 11A-C, E, F). (West, Central and East Africa) . . . . .	<i>militaris</i> Szombathy (p. 30)
-	Not with combination of characters given above . . . . .	21
21	More slender species with elongate abdomens (Figs 25A-F; 29A; 31A, B); tibia plus patellae IV to carapace length equal to or less than 0.74. . . . .	22
-	More robust species with less elongate abdomens (Figs 10B; 36A; 38A; 41A-C); tibia plus patellae IV to carapace length equal to or more than 0.76 . . . . .	24
22	Orange species (Fig. 31A, B); abdomen usually with ventral scutum. (East and Southern Africa)	
	<i>ichneumon</i> (Simon) (p. 56)	
-	Orange-brown to blackish species; ventral scutum lacking . . . . .	23



23	Inner keels of chelicerae more concave distally (Fig. 25A–F); tibiae of palp with dorsal and ventral surfaces less curved (Fig. 28B, C, D, E). (West, Central and East Africa)	<i>elongata</i> Szombathy (p. 50)
–	Inner keels of chelicerae less concave distally (Fig. 29F, G); palpal tibiae with dorsal and ventral surfaces more curved (Fig. 29C). (Zaire).	<i>lulungensis</i> Roewer (p. 55)
24	Tibial apophysis very robust (Fig. 13F). (Botswana, Kenya, Zaire)	<i>lulungana</i> Roewer (p. 33)
–	Tibial apophysis otherwise	25
25	Flange well developed with dorsal indentation (Fig. 11G). (Central and East Africa)	<i>lawrencei</i> Roewer (p. 32)
–	Flange otherwise	26
26	Tibial apophysis less elongate, flange well developed in lateral view (Fig. 37B); chelicerae relatively broad (Fig. 36A, E). (Egypt, Libya, Soudan, Yemen)	<i>tristis</i> (Simon) (p. 63)
–	Tibial apophysis more elongate, flange less well developed (Figs 39E, G; 42J; 43F); chelicerae relatively narrow, except in dwarfs (Figs 40A–K; 41A–C; 43C)	27
27	Abdomen pubescent; carapace with white hairs sometimes forming a longitudinal thoracic fringe (Pl. 4a); tegulum and embolus relatively large (Fig. 39C). (Africa excluding North and North East)	<i>marshalli</i> Peckham & Peckham (p. 67)
–	Abdomen not markedly pubescent; carapace sparsely clothed with very fine hairs, fringe lacking (Pl. 4b); tegulum and embolus relatively small	28
28	Carapace light coloured (yellow-brown); shape as in Fig. 43A. (Mali)	<i>bamakoï</i> Berland & Millot (p. 73)
–	Carapace darker (brown-black); shape as in Fig. 41A–C. (Ghana, Ivory Coast)	<i>legon</i> sp. n. (p. 69)
29	Cheliceral fang with double apophysis (Fig. 51F); carapace as in Fig. 51A, B. (Angola, Botswana)	<i>dundoensis</i> sp. n. (p. 82)
–	Not with combination of characters given above	30
30	Flange present (Fig. 15F–H)	31
–	Flange absent (Figs 45F, 53C; 58C)	32
31	Carapace with more distinct thoracic 'hump' (Fig. 14G); palp as in Fig. 15B, H, tegulum more swollen. (Angola)	<i>luachimo</i> sp. n. (p. 37)
–	Carapace with less distinct 'hump' (Fig. 14F); palp as in Fig. 15A, F, G, tegulum less swollen. (Angola, Kenya, Zaire)	<i>giltayi</i> Roewer (p. 36)
32	Seminal reservoir large (Figs 63B, C; 67A); chelicerae with lower distal margin of fang groove lobate (Figs 64C, D; 66D)	33
–	Seminal reservoir medium to small (Figs 46L; 55D, E; 59C); chelicerae otherwise	36
33	Carapace relatively high (Fig. 63E, F)	34
–	Carapace low (Fig. 66G). (Angola, Zaire)	<i>andrewi</i> sp. n. (p. 103)
34	Chelicerae with small retrolateral spurs (Figs 63A; 64C); tibial apophysis without minute dorsal spike (Fig. 63I). (Mozambique, South Africa)	<i>laurentina</i> Bacelar (p. 99)
–	Chelicerae without spurs (Figs 63D; 64D); tibial apophysis with minute dorsal spike (Fig. 63J, K). (Kenya)	<i>kilifi</i> sp. n. (p. 102)
35	Fang apophysis lacking (Fig. 46E)	36
–	Fang apophysis present (Fig. 48G; 45C)	38
36	Carapace as in Fig. 53B; ventral abdominal scutum present. (Angola, Botswana, South Africa)	<i>foreli</i> Lessert (p. 85)
–	Carapace otherwise; ventral abdominal scutum lacking	37
37	More slender species with slender tibial apophysis (Fig. 54C); tibia plus patella IV equal to or larger than carapace length. (Africa excluding North, North East and South West)	<i>uvira</i> sp. n. (p. 86)
–	More robust species with thicker tibial apophysis (Fig. 46B); tibia plus patella IV less than carapace length. (South Africa)	<i>solitaria</i> Peckham & Peckham (p. 75)
38	Anterior third of sternum yellowish, posterior two-thirds black; carapace as in Fig. 57F, K. (Ivory Coast)	<i>vanessae</i> sp. n. (p. 91)
–	Sternum and carapace otherwise	39
39	Body form as in Fig. 45A, G; fang arched proximally (Fig. 45C). (Madagascar)	<i>cowanii</i> (Peckham & Peckham) (p. 73)
–	Body form and fang otherwise. (Africa)	40
40	Carapace as in Fig. 58A; tegulum very small (Fig. 58E). (Nigeria)	<i>russellsmithi</i> sp. n. (p. 92)
–	Carapace and tegulum otherwise	41
41	Tibia plus patella IV to carapace length less than 0.76	42

-	Tibia plus patella IV to carapace length equal to or more than 0.83 . . . . .	43
42	Palp as in Figs 59D; 60B; thoracic hump more pronounced (Fig. 59I). (Kenya)	<i>kitale</i> sp. n. (p. 94)
-	Palp as in Figs 59C; 60A; thoracic hump less pronounced (Fig. 59F, G). (South Africa)	<i>inflatipalpis</i> sp. n. (p. 95)
43	Tegulum with cleft in anterior margin (Fig. 49B, C) . . . . .	44
-	Cleft lacking . . . . .	45
44	Cleft shallow, tibial apophysis more slender (Fig. 49B, E); metatarsi I with 2-2 ventral spines. (South Africa) . . . . .	<i>leleupi</i> sp. n. (p. 80)
-	Cleft deeper, tibial apophysis thicker (Fig. 49C, F); metatarsi I with 2-2-2-2 or 2-2-2 ventral spines. (Zaire) . . . . .	<i>uelensis</i> sp. n. (p. 82)
45	Chelicerae widest proximally (Figs 55A, 56A); fang apophysis short (Fig. 56G, H). (West Africa)	<i>nigeriensis</i> sp. n. (p. 88)
-	Chelicerae widest medially (Fig. 47A); fang apophysis long (Fig. 48G). (North East, East and Southern Africa) . . . . .	<i>kiboschensis</i> Lessert (p. 78)

## Females

1	Pedichel exceedingly long, anterior segments nearly 10 times length of posterior one (Fig. 73B). (Madagascar) . . . . .	<i>eumenes</i> (Simon) (p. 114)
-	Pedichel otherwise . . . . .	2
2	Spermathecae very large (Fig. 83C, E). (Madagascar) . . . . .	<i>ransonii</i> sp. n. (p. 124)
-	Spermathecae otherwise . . . . .	3
3	Epigyne as in Fig. 72A-C, spermathecae and proximal seminal ducts convoluted. (Madagascar)	<i>nubilis</i> (sp. n. (p. 111)
-	Epigyne otherwise . . . . .	4
4	Epigyne as in Fig. 72D-F, spermathecae and proximal seminal ducts coiled. (Madagascar)	<i>mahasoa</i> sp. n. (p. 112)
-	Epigyne otherwise . . . . .	5
5	Distal seminal ducts coiled (Figs 76C; 77C, D; 80C, D). (Madagascar) . . . . .	6
-	Distal seminal ducts apparently lacking or poorly defined . . . . .	8
6	Thoracic slope precipitous, posterior margin truncate (Fig. 75B); epigyne as in Fig. 76C, E	<i>eugenei</i> nom. n. (p. 115)
-	Thoracic slope not precipitous; epigyne otherwise . . . . .	7
7	More slender species (Fig. 79B); distal seminal ducts with 4 or 5 spirals (Fig. 80D)	<i>peckhami</i> Roewer (p. 119)
-	More robust species (Fig. 77A); distal seminal ducts with 6 or 7 spirals (Fig. 77C-D)	<i>andringitra</i> sp. n. (p. 117)
8	Epigyne with median subtriangular pouch (Figs 46I, J; 48H, K; 53G; 54K; 57C, D; 62A-E)	9
-	Epigyne with paired pouches (Figs 11H-K; 15C-E; 18C, D; 19F-H; 28F, G; 31D) . . . . .	23
9	Spermathecae more simple ovoid or elongate ovoid, sometimes bowed (Fig. 62A-E) . . . . .	10
-	Spermathecae more complex, looped or twisted (Figs 46J; 48I; 56K) . . . . .	15
10	More slender species (Fig. 66A, B); carapace low, not constricted (Fig. 66G, I) . . . . .	11
-	More robust species; carapace higher with shallow constriction . . . . .	12
11	Thoracic slope lacking (Fig. 66I); abdomen very long and tapered (Fig. 66A). (Madagascar)	<i>longiventris</i> (Simon) (p. 105)
-	Thoracic slope present (Fig. 66G); abdomen cigar-shaped (Fig. 66B). (Angola, Zaire)	<i>andrewi</i> sp. n. (p. 103)
12	Eye region punctured-reticulate between moderately dense piliferous papillae (Pl. 3a, b); spermathecae globular (Fig. 62D, E). (Angola, Zaire) . . . . .	<i>globosa</i> sp. n. (p. 99)
-	Not with combination of characters given above . . . . .	13
13	Eye region punctured-reticulate with ripples between PL; epigyne as in Fig. 65I, J. (Kenya)	<i>kilifi</i> sp. n. (p. 102)
-	Not with combination of characters given above . . . . .	14
14	Thorax sparsely clothed with long, fine whitish hairs; spermathecae curved (Fig. 62A-C). (Madagascar) . . . . .	<i>volatilis</i> (Peckham & Peckham) (p. 98)
-	Thorax sparsely clothed with long, white lanceolate hairs; spermathecae globular (Fig. 65G, H). (South Africa) . . . . .	<i>laurentina</i> Bacelar (p. 99)
15	Elongate species (Fig. 44A); spermathecae convoluted (Fig. 44D). (Madagascar)	<i>cowanii</i> (Peckham & Peckham) (p. 73)

-	Not with combination of characters given above. (Africa)	16
16	Tibia plus patellae IV to carapace length equal to or less than 0.73	17
-	Tibia plus patellae IV to carapace length equal to or more than 0.80	19
17	More slender species with shallow postocular constriction (Fig. 53A, E). (Angola, Botswana, South Africa)	<i>foreli</i> Lessert (p. 85)
-	More robust species with deeper postocular constriction	18
18	Carapace as in Fig. 46G, D; spermathecae looped (Fig. 46J). (South Africa)	<i>solitaria</i> Peckham & Peckham (p. 75)
-	Carapace as in Fig. 59E, H; spermathecae looped with a slight twist (Fig. 60K-M). (Kenya)	<i>kitale</i> sp. n. (p. 94)
19	Carapace as in Fig. 57A, G; anterior half of sternum and coxae I-II whitish, posterior half and coxae III-IV blackish. (Ivory Coast)	<i>vanessae</i> sp. n. (p. 91)
-	Carapace, sternum and coxae otherwise	20
20	Quadrangle length to carapace length equal to or less than 0.39	21
-	Quadrangle length to carapace length equal to or more than 0.41	22
21	Legs I with blackish tarsi; epigyne as in Fig. 52B, D, E. (Angola, Botswana)	<i>dundoensis</i> sp. n. (p. 82)
-	Legs I with whitish or light yellowish tarsi; epigyne as in Fig. 54K-M. (Africa excluding North, North East and South West)	<i>uvira</i> sp. n. (p. 86)
22	More slender species (Fig. 55C); epigyne as in Fig. 56I, K, L. (Nigeria)	<i>nigeriensis</i> sp. n. (p. 88)
-	More robust species, carapace, Fig. 48E, F; epigyne as in Fig. 48H-K. (Botswana, Kenya, Sudan, Tanzania)	<i>kiboschensis</i> Lessert (p. 78)
23	Thorax very long (Fig. 18A, E); epigyne as in Fig. 18C, D. (South Africa)	<i>natalica</i> Lessert (p. 39)
-	Thorax and epigyne otherwise	24
24	Carapace constriction deep but thorax very low (Fig. 33E); dorsal surface of abdomen with darker bands on lighter background (Fig. 33B). (West and Central Africa)	<i>foenisex</i> Simon (p. 60)
-	Carapace and abdomen otherwise	25
25	Carapace with more or less distinct thoracic hump (Fig. 14E); spermathecae relatively simple (Fig. 15D, E). (Angola)	<i>luachimo</i> sp. n. (p. 37)
-	Carapace and epigyne otherwise	25
26	Cephalic part with subparallel sides in dorsal view (Fig. 19A, I).	27
-	Cephalic part with curved sides in dorsal view	28
27	Lateral pouches situated at distal end of proximal seminal ducts (Fig. 19C). (Fernando Po, Ghana)	<i>insulana</i> Roewer (p. 40)
-	Lateral pouches situated midway along proximal seminal ducts (Fig. 19D). (Angola)	<i>mussungue</i> sp. n. (p. 42)
28	Body form more elongate (Figs 27B; 31C)	29
-	Body form less elongate	30
29	Light orange species (Fig. 31C, E); Epigyne with contiguous lateral pouches (Fig. 31D, F). (East and Southern Africa)	<i>ichneumon</i> (Simon) (p. 56)
-	Darker species (orange-brown or brown-black) (Figs 26F, 27B); epigyne with separate lateral pouches (Fig. 28F-I). (West, Central and East Africa)	<i>elongata</i> Szombathy (p. 50)
30	Epigyne as in Fig. 37C-E, lateral pouches relatively large; carapace with two long trichobothria in mid-dorsal region of postocular constriction. (Egypt, Libya, Soudan, Yemen)	<i>tristis</i> (Simon) (p. 63)
-	Epigyne otherwise; carapace with four long trichobothria in mid-dorsal region of postocular constriction	31
31	Lateral pouches approximate or contiguous	32
-	Lateral pouches widely separate	33
32	Tibia plus patella IV to carapace length equal to or greater than 0.92; usually a scanty, longitudinal white haired fringe on thorax; epigyne usually indistinct (Fig. 39A, B). (Africa excluding North, North East and South West)	<i>marshalli</i> Peckham & Peckham (p. 67)
-	Tibia plus patella IV to carapace length equal to or less than 0.90; thoracic fringe lacking; epigyne usually very indistinct (Fig. 42K). (Ghana, Ivory Coast)	<i>legon</i> sp. n. (p. 69)
33	Epigyne as in Fig. 12J, K; spermathecae more complex, proximal seminal ducts more slender. (Botswana, Kenya, Zaire)	<i>lulengana</i> Roewer (p. 33)
-	Epigyne as in Fig. 11H-K; spermathecae simpler, proximal seminal ducts wide	<i>lawrencei</i> Roewer or <i>militaris</i> Szombathy (p. 32, 30)



### The *tristis*-group

Male palp with tibial apophysis hooked (Fig. 28B, C) or rarely sigmoid (Fig. 17B); flange present, usually well developed; proximal ectal margin of cymbium depressed, fringed with setae; embolus long and slender. Epigyne with lateral pouches.

The *tristis*-group is mainly African in distribution but it also occurs in the Palaearctic and Oriental regions. It is essentially based on the female genitalia which are characterized by the lateral pouches. Most males are readily placed in this group by the hooked tibial apophysis but some species (e.g. *M. eidmanni* Roewer, *M. giltayi* Roewer and *M. luachimo* sp. n.) with a sigmoid

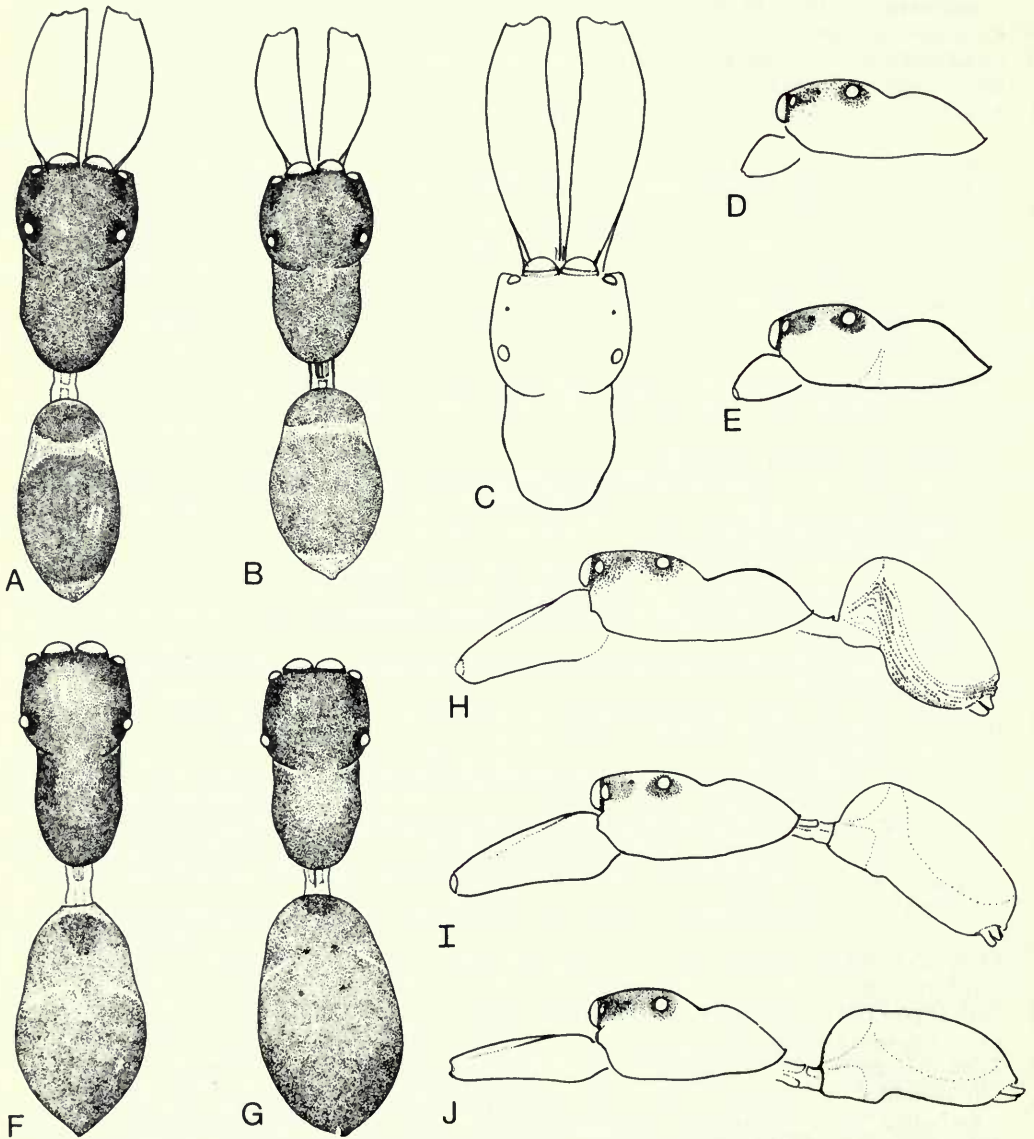
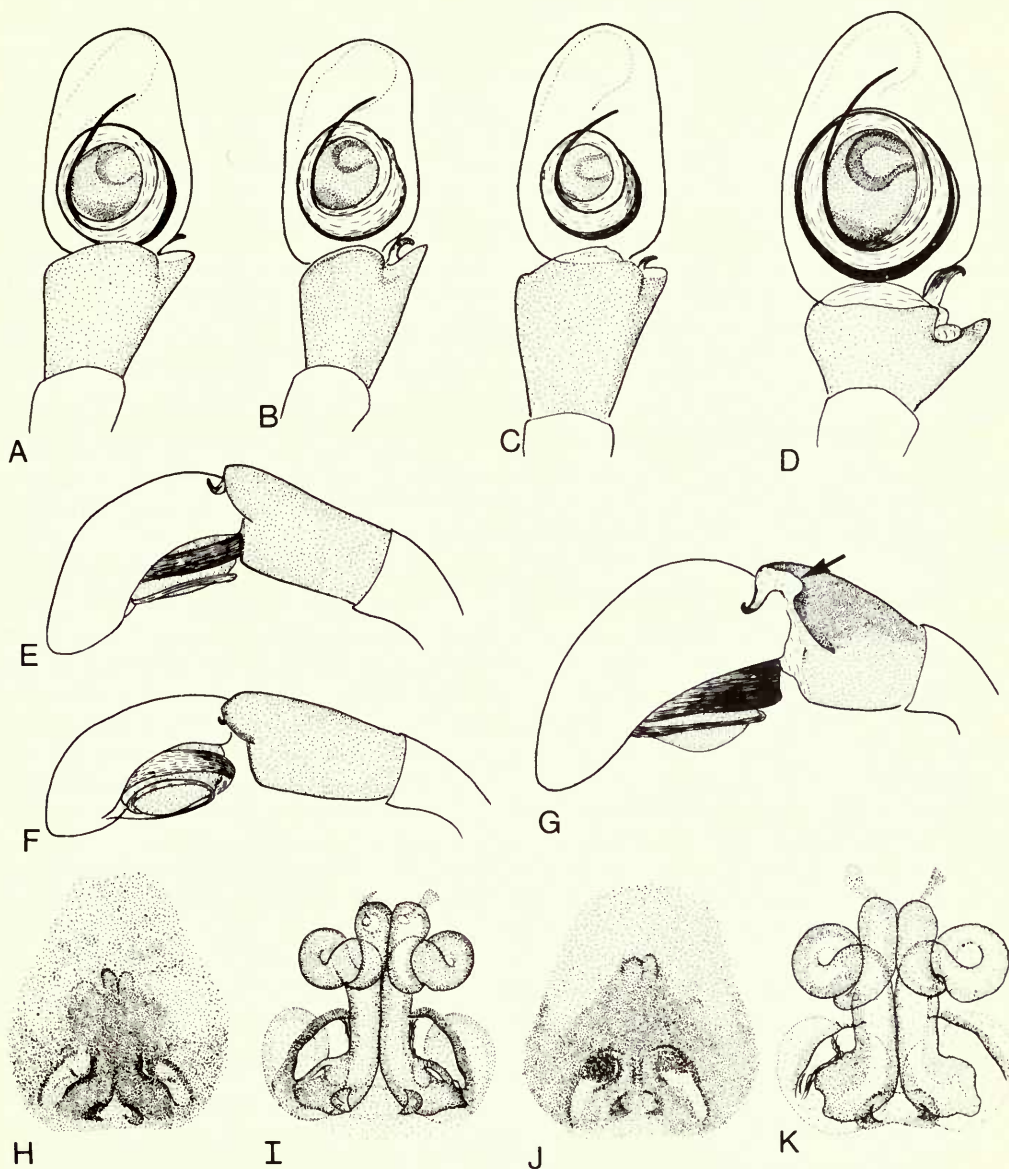

Fig. 10 (A, E, F, H, I) *Myrmarachne militaris* Szombathy. Lectotype ♂: (A) dorsal view; (I) lateral view. Holotype ♂ of *M. schoutedeni* Roewer: (H) lateral view. ♀ from Kenya: (F) dorsal view; (E) carapace, lateral view. (B, C, D, G, J) *Myrmarachne lawrencei* Roewer. Holotype ♂: (B) dorsal view; (J) lateral view. ♂ from Gabon: (C) carapace, dorsal view. Paratype ♀: (G) dorsal view; (D) carapace, lateral view.

tibial apophysis are intermediate between the *tristis* and *formicaria*-groups. *M. luachimo* is known in both sexes and it certainly belongs here but *eidmanni* and *giltayi* are only known from males and their position is a little uncertain.

The 24 species constituting this large group in the Ethiopian region are in some cases difficult to separate as there is marked allometric variation. Some species (e.g. *M. marshalli* Peckham & Peckham, *M. legon* sp. n. *M. elongata* Szombathy and *M. ichneumon* (Simon)) vary greatly in size and the smallest forms or dwarfs cannot readily be distinguished from one another. The



**Fig. 11** (A-C, E, F, H, I) *Myrmarachne militaris* Szombathy. Lectotype ♂: (A) palp, ventral view; (E) palp, lateral view. Holotype ♂ of *M. paucidentata* Berland & Millot: (B) palp, ventral view; (F) palp, lateral view. Holotype ♂ of *M. schoutedeni* Roewer: (C) palp, ventral view. ♀ from Kenya: (H) epigyne, ventral view; (I) vulva, ventral view. (D, G, J, K) *Myrmarachne lawrencei* Roewer. Holotype ♂: (D) palp, ventral view; (G) palp, lateral view. Paratype ♀: (J) epigyne, ventral view; (K) vulva, ventral view.

problem is aggravated by insufficient material and the suspicion that dwarf forms may be a widespread phenomenon.

Also in this group I have used the presence of either two or four trichobothria in the mid-dorsal region of the postocular constriction to separate three closely related species. These sensory hairs are long, smooth and sinuous and set in relatively large sockets. They are more robust than leg trichobothria but probably have an homologous function. The posterior pair, when present, are usually shorter than the anteriors but unfortunately their usefulness as a diagnostic character is limited by the fact that they are sometimes lost (rubbed) and their sockets cannot always be readily seen in very dark or strongly sculptured specimens.

### *Myrmarachne militaris* Szombathy

(Fig. 10E, F, H, I; 11A-C, E, F, H, I; 12A, B, E, H)

*Myrmarachne militaris* Szombathy, 1913 : 33, fig. 9, ♂. LECTOTYPE ♂ (here designated), Tanzania, Arusha (TM, B) [Examined]. Roewer, 1954 : 943. Bonnet, 1957 : 3010. Roewer, 1965 : 45, fig. 47.

*Myrmarachne maerens* Lessert, 1925 : 445, figs 23-25, ♂. Holotype ♂, Tanzania, Kibonoto culture zone (NR, Stockholm and M. L. N., Geneva) [Examined]. Caporiacco, 1940 : 855. Roewer, 1954 : 943. Bonnet, 1957 : 3009. Roewer, 1965 : 41, figs 51, 51a. Prószyński, 1971b : 439. **Syn. n.**

*Myrmarachne paucidentata* Berland & Millot, 1941 : 408, fig. 98a, b, c, ♂. Holotype ♂, Senegal, Dakar (MNHN, Paris) [Examined]. Roewer, 1954 : 943; 1965 : 73, fig. 53. **Syn. n.**

*Myrmarachne schoutedeni* Roewer, 1965 : 51, fig. 44, ♂. Holotype ♂, Zaire, Mauda (MRAC, Tervuren) [Examined]. Prószyński, 1971b : 440. **Syn. n.**

DIAGNOSIS. *M. militaris* closely resembles *M. lawrencei* Roewer and *M. lulengana* Roewer. Males are separated by the small tegulum (Fig. 11A, B, C) and pronounced flange which more or less obscures the tibial apophysis (Fig. 11E, F). Female *militaris* and *lawrencei* cannot be distinguished at present but they are both separated from *lulengana* females by the less complex spermathecae and wider seminal ducts (Fig. 11I).

MALE. *Carapace* (Fig. 10A, H, I): punctured-reticulate; brown-black; clothed with scattered, fine whitish hairs with white wedge-shaped bands in constriction. *Eyes*: anteriors subcontiguous with apices procurved, fringed with white hairs. *Clypeus*: fringed with light brownish hairs. *Chelicerae* (Fig. 12A, B, E): rugulose with furrows; orange-brown with black lateral keels; fang apophysis present. *Maxillae and Labium*: orange-brown tinged with black but inner margins of maxillae and labial tip lighter. *Sternum* (Fig. 12H): orange-brown tinged with black. *Abdomen* (Fig. 10A, I): mottled yellow-brown and black with dark orange-brown scuta; clothed with light golden or whitish hairs. *Legs*: slender, legs I tarsi and metatarsi brown-black; tibiae and patellae yellow-brown with brown-black lateral streaks; femora brown-black with distal yellow-brown streak inside; trochanters and coxae dark brownish. Legs II as I but tarsi and metatarsi yellow-brown. Legs III brown-black with tarsi yellow-brown. Legs IV as III but tarsi blackish tipped with yellow-brown; patellae marked with yellow-brown and trochanters whitish. Ventral spination of legs I: metatarsi 2-2, tibiae 2-2-2-2-2 or 2-2-2-2, patellae 0 or 1. *Palp* (Fig. 11A-C, E, F): tibial apophysis small, more or less obscured by fan-like flange which varies in development; proximal depression fringed with slender setae; seminal reservoir small and tegulum in relation to the cymbium also small.

*Dimensions*: total length 4.40-6.48 mm, carapace length 2.10-3.04 mm. *Ratios*: AM : AL : PM : PL : 9.5 : 5 : 1 : 5, AL-PM-PL : 7-6.5; a : 0.88-0.98, b : 0.95-1.0, c : 0.36-0.39, d : 0.64-0.8, e : 0.79-0.88 (10♂ examined).

FEMALE from Kenya, Kitale. *Carapace* (Fig. 10E, F): more or less as in ♂. *Eyes*: as in ♂. *Clypeus*: fringed with dark brown hairs. *Chelicerae*: medially rugulose; dark orange-brown; promargin with 6 or 7 teeth, retromargin with 7 or 9. *Maxillae and Labium*: as in ♂. *Sternum*: as in ♂. *Abdomen*: greyish with dark brown patch anteriorly and 4 impressed dots dorsally; clothed with bright golden hairs. *Legs*: slender; legs I tarsi and metatarsi brown-black; tibiae and patellae yellow-brown with blackish lateral streaks; femora brown black but distal venter



yellowish; trochanters and coxae brown-black but venters marked with yellowish. Legs II similar to I but femora yellowish with black sides; trochanters and coxae yellowish, the latter with black basal spots. Legs III and IV as in ♂. Ventral spination of legs I: metatarsi 2-2, tibiae 2-2-2, patellae 0. *Epigyne* (Fig. 11H, I): lateral pouches separate, spermathecae simple, basic figure of eight configuration; ducts relatively wide.

*Dimensions*: total length 5.44 mm, carapace length 2.48 mm. Ratios: AM : AL : PM : PL: 8.5 : 4.5 : 1 : 4, AL-PM-PL: 7-8.5; a: 1.04, b: 1.04, c: 0.39, e: 0.79 (1 ♀ examined).

**BIOLOGY.** Unknown.

**DISTRIBUTION.** Kenya, Malawi, Senegal, Tanzania, Zaire.

**MATERIAL EXAMINED.** Type data given in synonymy. **KENYA**: Kitale, 2000 m, taken from cells on reeds at edge of small freshwater dam, 1 ♀, 16.viii, 1 ♂ 22.viii.1972; beaten from shrubs in farm garden about 20 miles [32 km] north of Kitale, 1 ♀, 20.vii.1974 (*J. & F. Murphy*) (BMNH). **MALAWI**: Chintheche, 1 ♂, 30.xii.1975 (*R. Jocqué*, MT 148105) (MRAC, Tervuren). **TANZANIA**: 2nd Oxford University Tanganyika Expedition, Kasoje Camp, 1 ♂, 19.vii.1959 (*D. H. Eccles*); Katumbe, swept off burnt-over vegetation, 1 ♂, 10.vii.1959 (*J. A. L. Cooke*) (BMNH). **ZAIRE**:

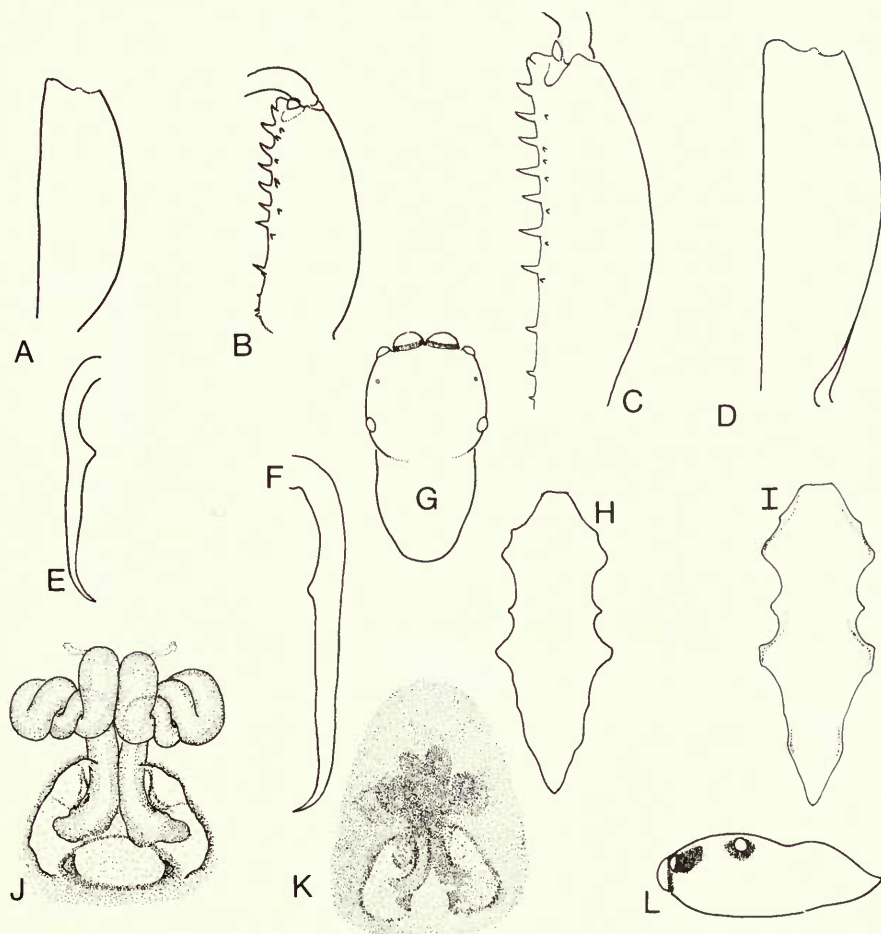

**Fig. 12** (A, B, E, H) *Myrmarachne militaris* Szombathy. ♂: (A) chelicera, dorsal view; (B) chelicera, ventral view; (E) fang; (H) sternum. (C, D, F, I) *Myrmarachne lawrencei* Roewer. ♂: (C) chelicera, ventral view; (D) chelicera, dorsal view; (F) fang; (I) sternum. (G, J-L) *Myrmarachne lulengana* Roewer. ♀ from Kenya: (G) carapace, dorsal view; (J) vulva, ventral view; (K) epigyne, ventral view; (L) carapace, lateral view.

Ituri, Olokoko, Faradje, 1♂, 2.ii.1930 (*A. Collart*, MT 130.771); Hte Uele, Moto, 2♂, xi.1922 (*L. Burgeon*, MT 130.760) (MRAC, Tervuren).

REMARKS. On the basis of the present material I am unable to find reliable characters for separating female *militaris* and *lawrencei*. Unfortunately the species are sympatric and differences in the abdominal pubescence may not be consistent. I have therefore not included data from several females of uncertain identity. A larger series of specimens should solve the problem but it should also be borne in mind that either of the females described here as *militaris* or *lawrencei* may be misidentified.

*Myrmarachne lawrencei* Roewer

(Figs 10B, C, D, G, J; 11D, G, J, K; 12C, D, F, I)

*Myrmarachne lawrencei* Roewer, 1965: 56, figs 59, 59a, ♂, ♀. Holotype ♂, Zaire, Kadjuju (MRAC, Tervuren) [Examined]. Prószyński, 1971b: 439.

DIAGNOSIS. *M. lawrencei* is closely related to *M. militaris* Szombathy and *M. lulengana* Roewer. Males are separated by the large, distally hooked tibial apophysis and pronounced flange which has a more or less distinct dorsal indentation (Fig. 11G). Female *lawrencei* are distinguished from female *lulengana* by the less complex spermathecae and wider seminal ducts (Fig. 11K), and doubtfully separated from *militaris* by the whitish abdominal pubescence.

MALE. *Carapace* (Fig. 10B, C, J): punctured-reticulate; orange-brown to brown-black with a violet sheen under some lights; sparsely clothed with fine whitish hairs with white wedge-shaped bands in constriction: *Eyes*: anterior subcontiguous with apices procurved, fringed with white hairs. *Clypeus*: fringed with light brown hairs. *Chelicerae* (Fig. 12C, D, F) rugulose with furrows; dark orange with black lateral keels; fang apophysis present. *Maxillae and Labium*: orange-brown tinged with black but inner margins of maxillae and labial tip lighter. *Sternum* (Fig. 12I): orange-brown with some blackish on margins. *Abdomen* (Fig. 10B, J): mottled brownish black with dark reddish brown scuta; clothed with whitish hairs with scattered, whitish lanceolate setae in constriction. *Legs*: slender; legs I tarsi and metatarsi blackish; tibiae and patellae light orange-brown with blackish lateral streaks; other segments orange-brown. Legs II light orange-brown with blackish streaks along inside of tibiae and patellae. Legs III orange-brown grading to light orange-brown on metatarsi and tarsi. Legs IV as III but trochanters and patellae marked with yellowish. Ventral spination of legs I: metatarsi 2-2, tibiae 2-1 or 2-2-1-2, patellae 0. *Palp* (Fig. 11D, G): tibial apophysis large with a distal hook; flange strongly developed with a dorsal indentation; proximal depression clearly fringed with stout setae; seminal reservoir of medium size but tegulum (in lateral view) somewhat bulbous.

*Dimensions*: total length 4.80-5.50 mm, carapace length 2.12-2.68 mm; *Ratios*: AM : AL : PM : PL: 8.5 : 4 : 1 : 4, AL-PM-PL: 6-7; a: 0.86-1.0, b: 0.94-1.0, c: 0.37-0.40, d: 0.70-1.0, e: 0.76-0.91 (4♂ examined).

FEMALE PARATYPE. *Carapace* (Fig. 10G, D): more or less as in ♂. *Eyes*: as in ♂. *Clypeus*: fringed with light brownish hairs. *Chelicerae*: medially rugulose; orange-brown; promargin with 5 teeth, retromargin with 8. *Maxillae and Labium*: as in ♂. *Sternum*: as in ♂. *Abdomen*: greyish with a dark brown patch anteriorly and 4 impressed dots dorsally; clothed with fine whitish hairs with a very scanty band of whitish lanceolate setae in constricted area. *Legs*: slender; legs I tarsi orange-brown; metatarsi blackish; tibiae and patellae light orange-brown with blackish lateral streaks; femora dark orange-brown with distal, dorsal and ventral parts yellowish; trochanters brown with venter yellow-brown; coxae yellow-brown with inner sides blackish. Legs II yellow-brown with black streaks along sides of tibiae, patellae and femora; also a blackish spot on outside of coxae. Legs III and IV as in ♂. Ventral spination of legs I: metatarsi 2-2, tibiae 2-2-2, patellae 0. *Epigyne* (Fig. 11J, K): lateral pouches separate; spermathecae simple, basic figure of eight configuration; ducts relatively wide.

*Dimensions*: total length 5.30 mm, carapace length 2.32 mm. *Ratios*: AM : AL : PM : PL: 8.5 : 4 : 1 : 4.5, AL-PM-PL: 6-7, a: 1.04, b: 1.04, c: 0.37, e: 0.81 (1♀ examined).

BIOLOGY. Unknown.

DISTRIBUTION. Gabon, Kenya, Tanzania, Zaire.

MATERIAL EXAMINED. Holotype ♂, data given in synonymy. GABON: 1 ♂ (ex coll, Simon) (MNHN, Paris). KENYA: Nairobi, 1 ♂, 13.viii.1959 (*J. G. Williams*) (BMNH). TANZANIA: Kasoje, Kangwena Camp, on breakfast table, 1 ♂, 10.ix.1959 (*D. H. Eccles*) (BMNH).

REMARKS. Several unaccompanied females from Zaire, thought to belong with this species, have not been formally included in the descriptions or material examined as I still have doubts as to the identification of females (see remarks under *M. militaris*, p. 000).

*Myrmarachne lulengana* Roewer

(Figs 12G, J-L; 13A-H)

*Myrmarachne lulengana* Roewer, 1965 : 50, fig. 42, ♂. Holotype ♂, Zaire, Lulenga (MRAC, Tervuren) [Examined]. Prószyński, 1971b : 439.

DIAGNOSIS. *M. lulengana* is closely related to *M. lawrencei* Roewer and *M. militaris* Szombathy.

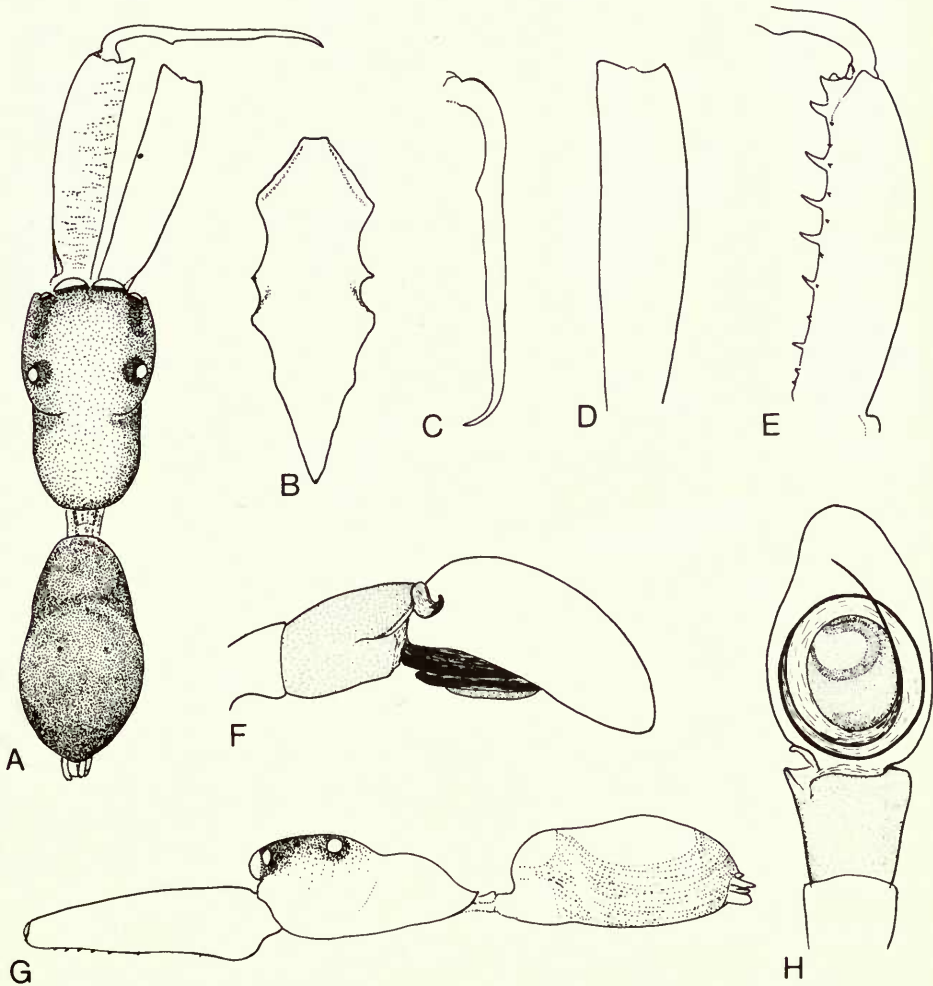

Fig. 13 *Myrmarachne lulengana* Roewer. Holotype ♂: (A) dorsal view; (B) sternum; (C) fang; (D) chelicera, dorsal view; (E) chelicera, ventral view; (F) palp, lateral view; (G) lateral view; (H) palp, ventral view.



Males are separated by the robust tibial apophysis and pronounced flange (Fig. 13F). Females are distinguished from female *militaris* and *lawrencei* by the more complex spermathecae and more slender ducts (Fig. 12J).

MALE. *Carapace* (Fig. 13A, G): punctured-reticulate with papillae on thoracic part; orange-brown to brown-black with scattered, fine white hairs and white haired wedges in constriction. *Eyes*:

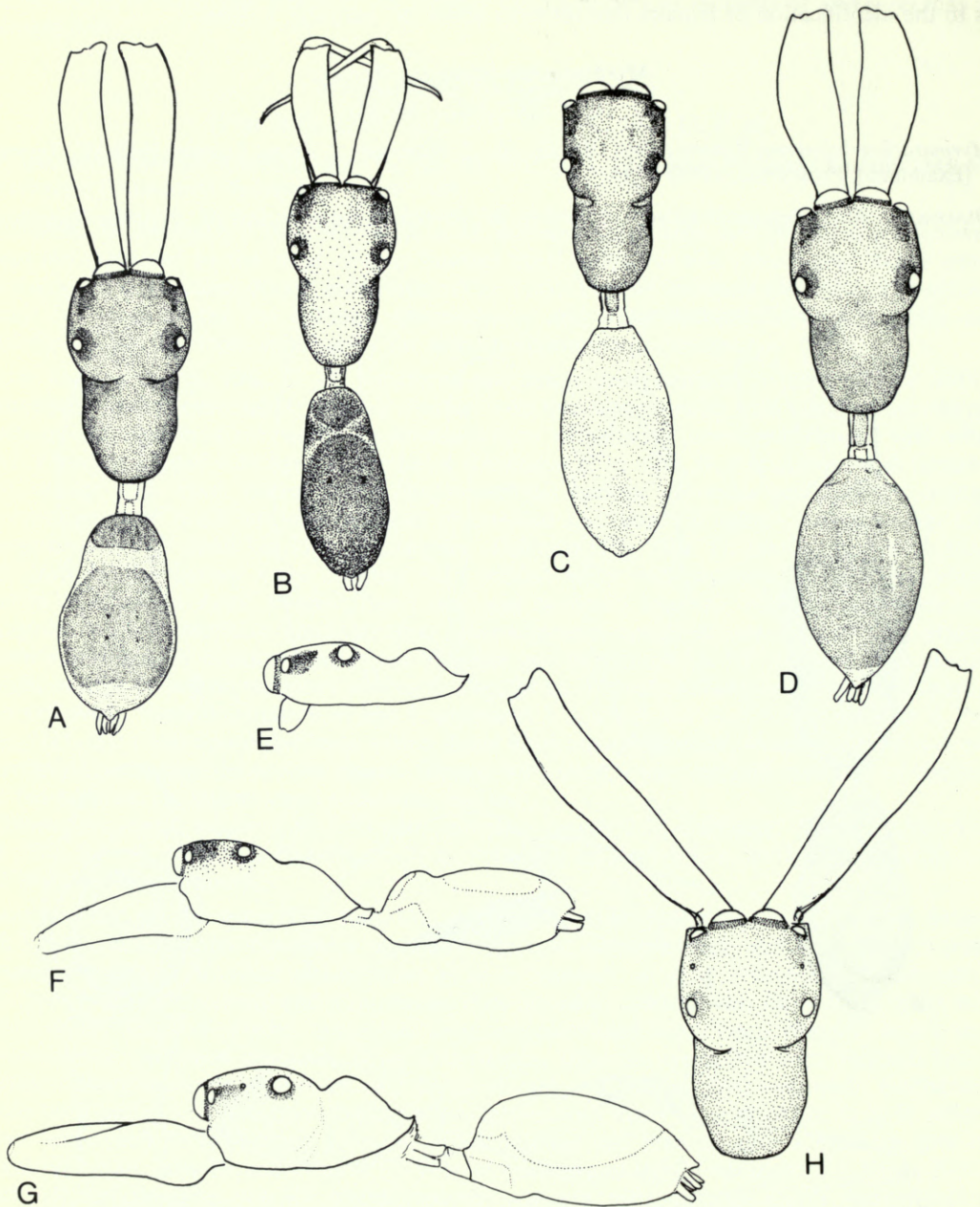

Fig. 14 (A, B, F, H) *Myrmarachne giltayi* Roewer. ♂ from Angola: (A) dorsal view. Holotype ♂: (B) dorsal view; (F) lateral view. ♂ from Zaire: (H) carapace, dorsal view. (C, D, E, G) *Myrmarachne luachimo* sp. n. Paratype ♀: (C) dorsal view; (E) carapace, lateral view. Holotype ♂: (D) dorsal view; (G) lateral view.

anteriorly subcontiguous with apices procurved, fringed with whitish hairs. *Clypeus*: fringed with long whitish hairs. *Chelicerae* (Fig. 13C–E): rugulose with furrows; orange-brown; fang apophysis present. *Maxillae and Labium*: orange-brown tinged with black but inner margin of maxillae and labial tip lighter. *Sternum* (Fig. 13B): orange-brown tinged with black with some darkening around the margins. *Abdomen* (Fig. 13A, G): blackish with dark orange-brown scuta; clothed with fine whitish hairs and scattered, whitish lanceolate setae in constriction and fore part of posterior scutum. *Legs*: slender; legs I tarsi and metatarsi yellow-brown tinged with blackish; tibiae and patellae yellow-brown with blackish lateral streaks; femora dark brownish; trochanters and coxae yellow-brown the former with blackish sides. Legs II yellow-brown but inside of tibiae, patellae and femora brown-black. Legs III dark orange-brown but distal tibiae, metatarsi and tarsi yellow-brown and trochanters and coxae orange-brown tinged with black. Legs IV dark orange-brown but trochanters, metatarsi distally and tarsi yellow-brown with yellow-brown mark on patellae. Ventral spination of legs I: metatarsi 2–2; tibiae 2–2–1–2; patellae 0. *Palp* (Fig. 13F, H): tibial apophysis robust; flange well developed; proximal depression fringed with stout setae; seminal reservoir of medium size. In small specimens there is a tendency for the tibiae to be deeper anteriorly and resemble that of *M. lawrencei*.

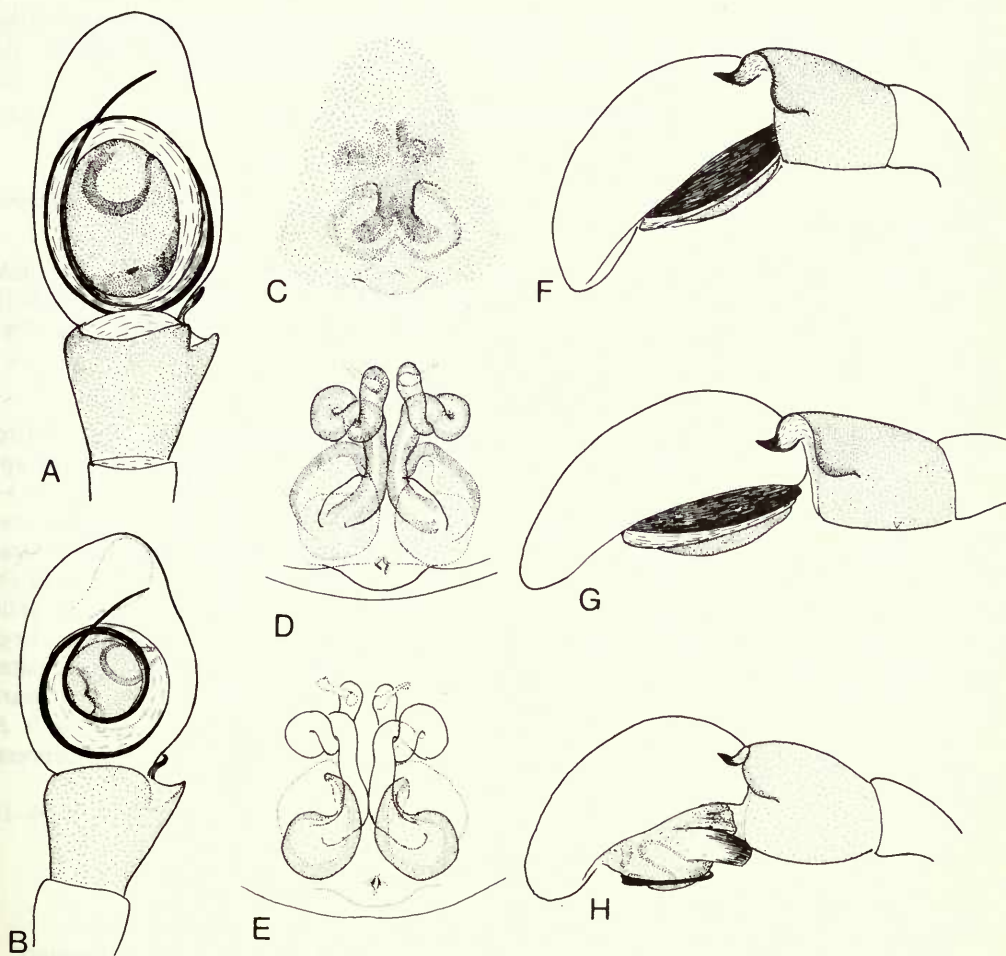

Fig. 15 (A, F, G) *Myrmarachne giltayi* Roewer. Holotype ♂: (A) palp, ventral view; (F) palp, lateral view. ♂ from Angola, (G) palp, lateral view. (B–E, H) *Myrmarachne luachimo* sp. n. Holotype ♂: (B) palp, ventral view; (H) palp, lateral view. Paratype ♀: (C) epigyne ventral view; (D) vulva, ventral view; (E) vulva, dorsal view.



*Dimensions*: total length 3.8–5.3 mm, carapace length 1.62–2.56 mm. *Ratios*: AM : AL : PM : PL : 10 : 5.2 : 2 : 6, AL–PM–PL : 7–7; a : 0.92–0.98, b : 0.97–1.0, c : 0.40–0.41, d : 0.50–1.0, e : 0.72–0.83 (4♂ examined).

**FEMALE.** *Carapace* (Fig. 12G, L): punctured-reticulate; brown-black with scattered fine white hairs and white-haired wedges in constriction. *Eyes*: more or less as in ♂. *Clypeus*: fringed with long light brown hairs. *Chelicerae*: rugulose; orange-brown; promargin with 8 teeth, retro-marginal with 7. *Maxillae and Labium*: as in ♂. *Sternum*: dark orange-brown tinged with black. *Abdomen*: blackish with a dark brownish patch anteriorly; clothed with dull whitish hairs more or less distributed as in ♂. *Legs*: as in ♂ but ventral spination of legs I: metatarsi 2–2, tibiae 1–2–1 or 2–2–2–2, patellae 0. *Epigyne* (Fig. 12J, K): lateral pouches separate; spermathecae more complex than basic figure of eight configuration.

*Dimensions*: total length 4.68–5.36 mm, carapace length 1.92–2.44 mm; *Ratios*: AM : AL : PM : PL : 7 : 3.5 : 1 : 4, AL–PM–PL : 5–7; c : 0.39–0.42, e : 0.73–0.77 (3♀ examined).

**BIOLOGY.** Unknown.

**DISTRIBUTION.** Botswana, Kenya, Zaire.

**MATERIAL EXAMINED.** Holotype ♂, data given in synonymy. **BOTSWANA**: Environs of Kewee Hills, in vehicle, 1♂, 30.iii.1976 (*A. Russell-Smith & F. Wanless*) (BMNH). **KENYA**: Lake Naivasha beaten from kei apple hedge, 2♂, 2♀, 3.viii.1974 (*J. & F. Murphy*) (BMNH). **ZAIRE**: Kivu, Nyanukuli, 1♀, 9.ii.1932 (*L. Burgeon*, MT 31286–7 part) (MRAC, Tervuren).

### *Myrmarachne giltayi* Roewer

(Figs 14A, B, F, H; 15A, F, G; 16D–F, H)

*Myrmarachne giltayi* Roewer, 1965 : 52, fig. 45, ♂. Holotype ♂, Zaire, Elizabethville (MRAC, Tervuren) [Examined]. Prószyński, 1971b : 438.

**DIAGNOSIS.** *M. giltayi* is a variable species, sympatric with *M. lulengana* Roewer and *M. luachimo* sp. n. It is closest to *luachimo* from which it is distinguished by the less bulbous tegulum (Fig. 15F, D) and lack of a distinct thoracic 'hump' (Fig. 14F); it is separated from *lulengana* by the form of the tibial apophysis (Fig. 15F, D).

**FEMALE.** Unknown.

**MALE.** *Carapace* (Fig. 14A, B, F, H): punctured-reticulate; orange-brown with fine, scattered white hairs and white-haired bands in constriction. *Eyes*: anteriors subcontiguous with apices procurved, fringed with whitish hairs. *Clypeus*: fringed with white hairs. *Chelicerae* (Fig. 16D–F): rugulose with furrows; orange-brown; fang apophysis present. *Maxillae and Labium*: orange tinged with black but inner margin of maxillae and labial tip lighter. *Sternum* (Fig. 16H): orange with darker margins. *Abdomen* (Fig. 14A, B, F): mottled yellow-brown and black with shiny orange-brown scuta, sparsely clothed with very fine hairs. *Legs*: slender; legs I tarsi yellow-brown; metatarsi blackish; remaining segments yellow-brown with sooty lateral streaks. Legs II as I but metatarsi yellow-brown. Legs III yellow-brown but coxae, trochanters, femora, patellae and sides of tibiae tinged with black. Legs IV as III but coxae, trochanters and patellae marked with light yellowish. Ventral spination of legs I: metatarsi 2–2, tibiae 2–2–2–2, patellae 0. *Palp* (Fig. 15A, F, G): tibial apophysis sigmoid and robust; flange well developed; proximal depression fringed with moderately stout setae; seminal reservoir of medium size.

*Dimensions*: total length 4.52–6.40 mm, carapace length 2.08–2.80 mm. *Ratios*: a : 0.94–1.02, b : 0.95–1.02, c : 0.39–0.41, d : 0.82–1.25, e : 0.75–0.87 (7♂ examined).

**BIOLOGY.** Unknown.

**DISTRIBUTION.** Angola, Kenya, Zaire.

**MATERIAL EXAMINED.** Holotype ♂, data given in synonymy. **ANGOLA**: Chutes Luisavo, 3♂, 23.ii.1955 (Local collector, Ang. 10018.20) (BMNH). **KENYA**: Lake Naivasha, beaten from kei apple hedge, 1♂, 3.viii.1974 (*J. & F. Murphy*) (BMNH). **ZAIRE**: Kivu, Kanyamavono Valley, Ruindi Plain, 1200 m, in dead wood, 1♂, 16.vi.1972 (*R. P. M. Lejeune*, MT 144.685); Lake Kivu, Isle Suhu, 1♂, 1.xii.1932 (*L. Burgeon*, MT 11809–10) (MRAC, Tervuren).



*Myrmarachne luachimo* sp. n.

(Figs 14C, D, E, G; 15B-E, H; 16A-C, G)

**DIAGNOSIS.** *M. luachimo* is sympatric with *M. giltayi* Roewer and *M. lulengana* Roewer. It is closely related to *giltayi* from which it is distinguished by the thoracic shape (Fig. 14E, G) and more bulbous tegulum (Fig. 15H). It is separated from *lulengana* by the shape of the thorax and the form of the tibial apophysis.

**MALE.** *Carapace* (Fig. 14D, G): punctured-reticulate; dark orange with white wedge-shaped bands in constriction. *Eyes*: anteriors more or less contiguous with apices procurved, sparsely fringed with whitish hairs. *Clypeus*: white haired. *Chelicerae* (Fig. 16A-C): rugulose with furrows; orange; fang apophysis a slight swelling. *Maxillae and Labium*: pale yellow-orange. *Sternum* (Fig. 16G): light orange. *Abdomen* (Fig. 14D, G): light yellowish with contiguous pale orange scuta. *Legs*: slender, light yellowish to pale orange. Ventral spination of legs I: metatarsi 2-2, tibiae 2-2 and 2-1, patellae 0. *Palp* (Fig. 15B, H): distal hook lacking; flange moderately developed; proximal depression fringed with moderately stout setae; tegulum bulbous.

*Dimensions*: total length 3.76 mm, carapace length 1.66 mm. *Ratios*: AM : AL : PM : PL : 8 : 3.5 : 1 : 4, AL-PM-PL: 4.5-6; a: 1.01, b: 1.0, c: 0.43, d: 0.86, e: 0.65 (1♂ examined).

**FEMALE.** *Carapace* (Fig. 14C, E): finely punctured-reticulate; dark orange, shiny with white haired bands in constriction. *Eyes*: more or less as in ♂. *Clypeus*: sparsely fringed with whitish hairs. *Chelicerae*: light orange; teeth not examined. *Maxillae and Labium*: orange-brown. *Sternum*: light orange, shiny. *Abdomen*: light yellowish tinged with grey; a scanty white haired

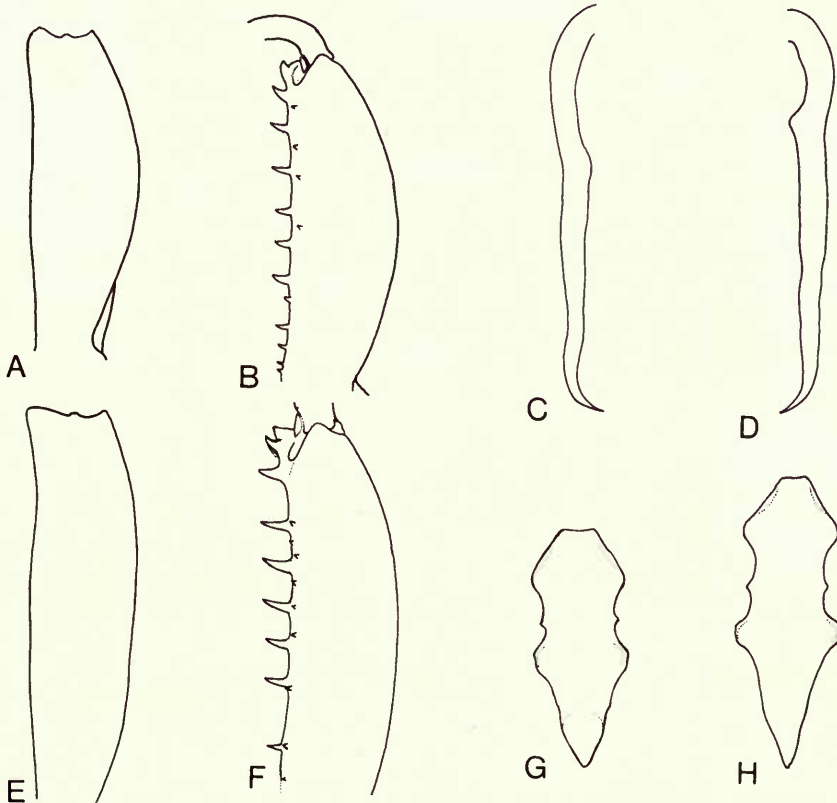

**Fig. 16** (A-C, G) *Myrmarachne luachimo* sp. n. ♂: (A) chelicera, dorsal view; (B) chelicera, ventral view; (C) fang; (G) sternum. (D-F, H) *Myrmarachne giltayi* Roewer. ♂: (D) fang; (E) chelicera, dorsal view; (F) chelicera, ventral view; (H) sternum.

band in constriction. *Legs*: slender; legs I whitish yellow with greyish streaks along inside of tibiae and patellae and on both sides of femora. Legs II as I but grey streaks on outside of femora lacking. Legs III with tarsi and metatarsi whitish yellow; tibiae whitish yellow with greyish proximally; patellae whitish yellow with grey distally; other segments yellow-brown tinged with grey. Legs IV as III but trochanters whitish. Ventral spination of legs I: metatarsi 2-2, tibiae 2-2-2, patellae 0. *Epigyne* (Fig. 15C-E): lateral pouches approximate; spermathecae simple, basic figure of eight configuration.

*Dimensions*: total length 3.76 mm, carapace length 1.56 mm. *Ratios*: AM : AL : PM : PL : 7.5 : 3.4 : 1 : 3.4, AL-PM-PL: 4.5-4; a: 1.02, b: 1.05, c: 0.41, e: 0.65 (1 ♀ examined).

*BIOLOGY*. Unknown.

*DISTRIBUTION*. Angola.

*MATERIAL EXAMINED*. Holotype ♂, ANGOLA: Dundo, forest gallery, R. Luachimo, collected with Japanese umbrella, 30.ix.1946 (*A. B. Machado*, Ang. 53.2) (MD, Dundo). Paratype ♀, Angola: forest gallery, R. Tchirimbo, in litter, 9.vii.1954 (*A. B. Machado*, Ang. 4323.49) (BMNH).

*ETYMOLOGY*. The specific name is a noun in apposition taken from the type-locality.

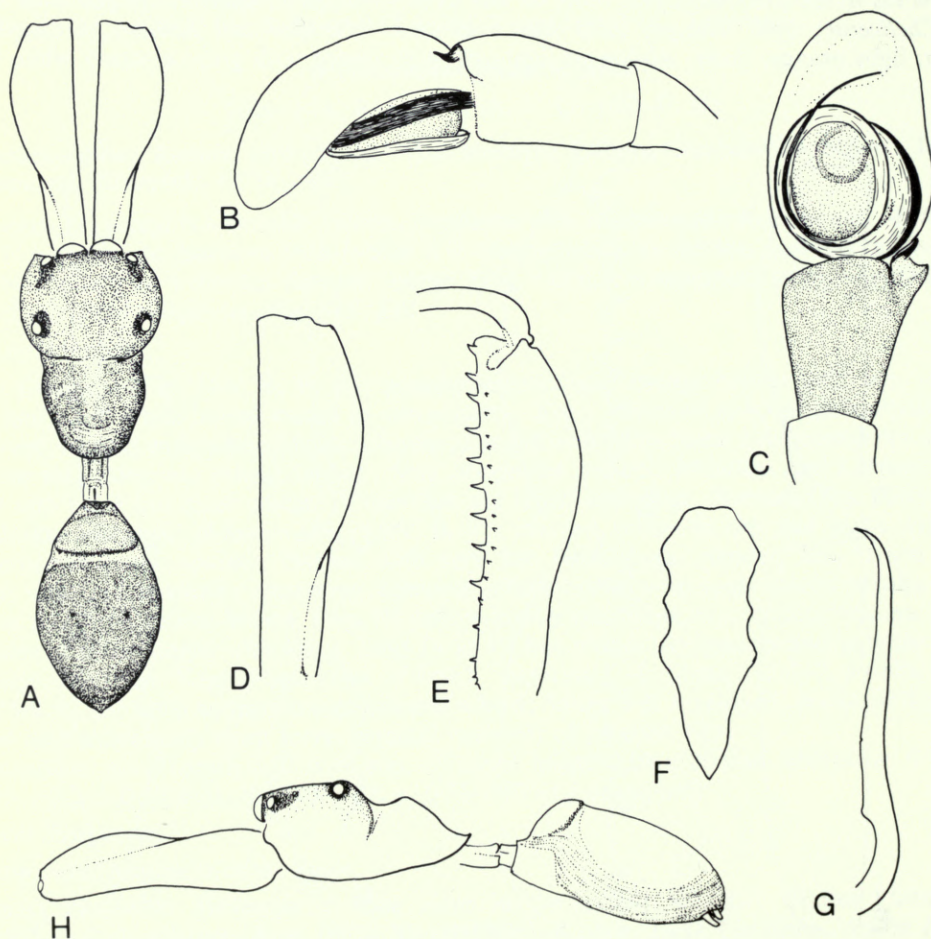

Fig. 17 *Myrmarachne eidmanni* Roewer. ♂ from Ghana: (A) dorsal view; (B) palp, lateral view; (C) palp, ventral view; (D) chelicera, dorsal view; (E) chelicera, ventral view; (F) sternum; (G) fang; (H) lateral view.

*Myrmarachne eidmanni* Roewer

(Fig. 17A-H)

*Myrmarachne eidmanni* Roewer, 1942 : 252, figs 8a, b-c, ♂ LECTOTYPE ♂ (here designated), Fernando Po, Musola (FS, Frankfurt am Main) [Examined]. Roewer, 1954 : 942; 1965 : 75, fig. 37. Prószyński, 1971b : 437.

*Myrmarachne punctata* Wanless & Clark, 1975 : 290, figs 29-35, ♂. Holotype ♂ Ivory Coast, Zepreghe, Dalao (MRAC, Tervuren) [Examined]. Syn. n.

DIAGNOSIS. *M. eidmanni* is distinguished from other species in the *tristis*-group by the combination of club-shaped chelicerae (Fig. 17A, D) and lack of a distal hook on the tibial apophysis (Fig. 17B). The form of the palp suggests that it is closely related to *M. luachimo* sp. n.

FEMALE. Unknown.

MALE. *Carapace* (Fig. 17A, H): punctured-reticulate; brown-black with a metallic sheen under some lights; sparsely clothed with whitish hairs forming very scanty, transverse bands on thoracic part with white haired bands in constriction. *Eyes*: anteriors subcontiguous with apices procurved, fringed with white hairs. *Clypeus*: white haired. *Chelicerae* (Fig. 17D, E, G): rugulose with furrows, a metallic sheen proximally; orange-brown with black lateral keels; fang apophysis small. *Maxillae and Labium*: brown-black but inner margins of maxillae and labial tip lighter. *Sternum* (Fig. 17F): orange-brown tinged with black. *Abdomen* (Fig. 17A, H): mottled yellow-brown and black with shiny, dark brownish scuta; thinly clothed with very fine whitish hairs; posterior spinnerets darkest. *Legs*: slender; legs I tarsi light yellow; metatarsi black; tibiae and patellae pale yellow-brown with black streaks along inside; femora brownish with inner sides darker; trochanters and coxae yellow-brown with darker sides. Legs II as I but metatarsi yellow-brown. Legs III with tarsi and metatarsi pale yellowish, remaining segments brownish tinged with some black. Legs IV tarsi pale yellowish; metatarsi yellowish becoming brownish proximally; tibiae and femora brown suffused with black; patellae brown marked with yellowish; trochanters and coxae yellowish with dark sides. Ventral spination of legs I: metatarsi 2-2, tibiae variable from 0 to 2-2-2, patellae 0. *Palp* (Fig. 17B, C): distal hook lacking; flange moderately developed; proximal ectal margin of cymbium slightly depressed, scantily fringed with fine setae.

*Dimensions*: total length 2.90-4.10 mm, carapace length 1.5-1.99 mm. *Ratios*: AM : AL, PM : PL: 7 : 3 : 1 : 3.6, AL-PM-PL: 6-8; a: 0.87-1.0, b: 0.93-1.0, c: 0.40-0.42, d: 0.79-1.20 e: 0.62-0.65 (9♂ examined).

BIOLOGY. Unknown but the abdominal shape suggests that this species mimics *Crematogaster* ants.

DISTRIBUTION. Fernando Po, Ghana, Ivory Coast, Zaire.

MATERIAL EXAMINED. Type data given in synonymy. GHANA: Kade, pyrethrum knockdown sample from a plot of Amelonado cocoa, 3♂, 24.ii.1971, 2♂, 10.ii.1971, 1♂, 23.ii.1972 (*J. D. Majer*) (BMNH). ZAIRE: Kivu, Muwe Valley, Ruindi Plain, 1100 m, 1♂, 22.vi.1972 (*R. P. M. Lejeune* MT 144.469) (MRAC, Tervuren).

*Myrmarachne natalica* Lessert

(Fig. 18A-E)

*Myrmarachne natalica* Lessert, 1925 : 344, fig. 11, ♀. Holotype ♀, South Africa, Natal, Amanzimtoti (NM, Pietermaritzburg) [Examined]. Roewer, 1954 : 943. Bonnet, 1957 : 3010. Roewer, 1965 : 70. Prószyński, 1971b : 439.

DIAGNOSIS. *M. natalica* is a distinctive species easily recognized by the unusually long thorax. Its affinities are uncertain but the structure of the epigyne suggests that it may be related to *M. insulana* Roewer. However, without the male, any conclusions on this species must be regarded as tentative.

MALE. Unknown.

FEMALE. *Carapace* (Fig. 18A, E): punctured-reticulate; dark brownish orange with scattered,



fine white hairs and white haired bands in constriction. *Eyes*: anterior subcontiguous with apices procurved, fringed with whitish hairs. *Clypeus*: white haired. *Chelicerae*: rugulose to smooth; orange, shiny; promargin with 6 or 7 teeth, retromargin with 8 or 9. *Maxillae and Labium*: brownish with inner distal margin of maxillae and labial tip paler. *Sternum* (Fig. 18B): dark brownish. *Pedicel*: rather long, segments subequal. *Abdomen* (Fig. 18A, E): mottled brownish black, a very scanty white haired band in constricted region. *Legs*: rather long and slender. Legs I tarsi and metatarsi yellowish; tibiae, patellae and femora light brown with black streaks along sides; trochanters and coxae whitish yellow. Legs II missing but coxae dark brown. Legs III tarsi and metatarsi yellow-brown; tibiae brownish orange; patellae brownish orange marked with yellowish; remaining segments brownish. Legs IV as III but trochanters yellowish and metatarsi orange-brown. Ventral spination of legs I: metatarsi 2-2, tibiae 2-2-2-2, patellae 0. *Epigyne* (Fig. 18C, D): lateral pouches apparently contiguous; spermathecae relatively complex.

*Dimensions*: total length 7.5 mm, carapace length 3.32 mm. *Ratios*: AM : AL : PM : PL : 11 : 5 : 1.5 : 5, AL-PM-PL: 6-7; a: 1.04, b: 1.04, c: 0.28, e: 0.98 (1 ♀ examined).

**BIOLOGY.** Unknown.

**DISTRIBUTION.** South Africa.

**MATERIAL EXAMINED.** Holotype ♀, data given in synonymy.

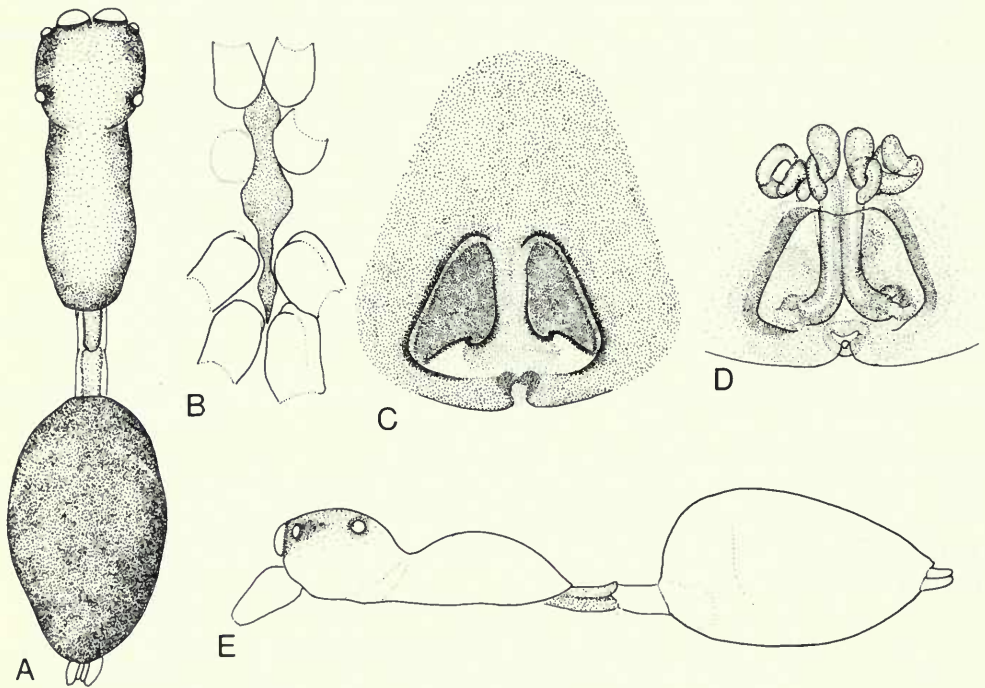

Fig. 18 *Myrmarachne natalica* Lessert. Holotype ♀: (A) dorsal view; (B) sternum; (C) epigyne, ventral view; (D) vulva, ventral view; (E) lateral view.

***Myrmarachne insulana* Roewer**

(Fig. 19A, B, C, F)

*Myrmarachne insulana* Roewer, 1942: 254, pl. 19, figs 10a-e, ♀. Holotype ♀, Fernando Po, Musola (FS, Frankfurt am Main) [Examined]. Roewer, 1954: 943; 1965: 75. Prószyński, 1971b: 438.

**DIAGNOSIS.** *Myrmarachne insulana* is a long slender species (Fig. 19A) closely related to *M. mussungue* sp. n., from which it may be distinguished by the shorter seminal ducts (Fig. 19C, F).

MALE. Unknown.

FEMALE. *Carapace* (Fig. 19A, B): finely punctured-reticulate; dark orange-brown with white haired bands in constriction. *Eyes*: anteriorly contiguous with apices procurved, fringed with white hairs. *Clypeus*: sparsely white haired. *Chelicerae*: rugulose; orange-brown, shiny; pro-marginal with 7 or 8 teeth, retromarginal with 7-10. *Maxillae and Labium*: orange-brown but inner distal margin of maxillae and labial tip paler. *Sternum*: elongate, narrow; orange-brown with a lighter central band and a dark brownish patch anteriorly. *Abdomen* (Fig. 19A): yellow-brown tinged with grey with a lighter central band and a dark brownish patch anteriorly. *Legs*: slender; legs I yellow-brown with blackish streaks on sides of metatarsi, tibiae, patellae and femora. Legs II yellow-brown. Legs III as II but outside of femora, trochanters and coxae blackish. Legs IV as III but sides of tibiae and inside of femora blackish. Ventral spination of legs I: metatarsi 2-2, tibiae 2-2-2-2, patellae 0. *Epigyne* (Fig. 19C, F): lateral pouches more or less contiguous; spermathecae complex; proximal seminal ducts moderately slender but not extending much beyond the lateral pouches.

*Dimensions*: total length 5.12-6.8 mm, carapace length 1.92-2.44 mm. *Ratios*: AM : AL : PM : PL: 8.5 : 4.5 : 1 : 4.5, AL-PM-PL: 5.5-6; a: 1.02-1.05, b: 1.02-1.05, c: 0.37-0.39, e: 0.72-0.75 (3 ♀ examined).

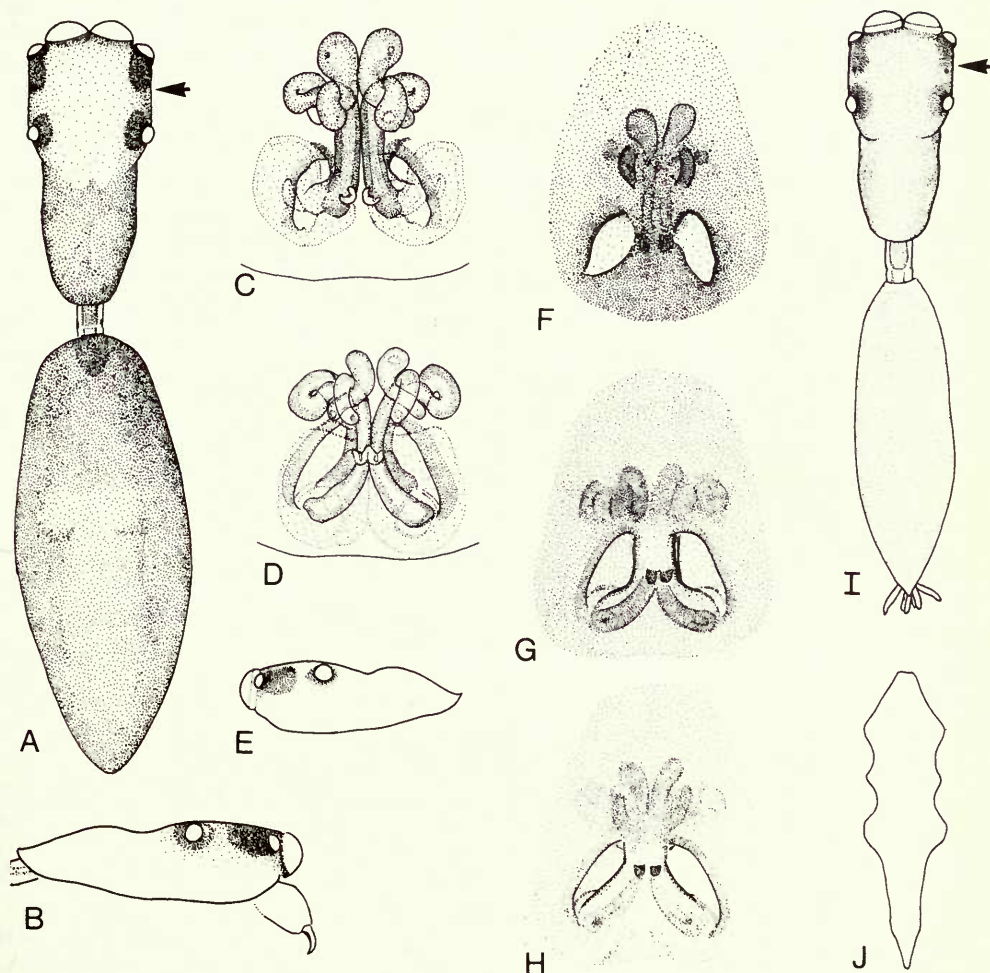

Fig. 19 (A, B, C, F) *Myrmarachne insulana* Roewer. Holotype ♀: (A) dorsal view; (B) carapace, lateral view; (C) vulva, ventral view; (F) epigyne, ventral view. (D, E, G-J) *Myrmarachne mus-sungue* sp. n. Holotype ♀: (D) vulva, ventral view; (E) carapace, lateral view; (H) epigyne, ventral view; (I) dorsal view; (J) sternum. Paratype ♀: (G) epigyne, ventral view.

BIOLOGY. Unknown but this species has been found with *Tetramorium* ants.

DISTRIBUTION. Fernando Po, Ghana.

MATERIAL EXAMINED. Holotype ♂, data given in synonymy. GHANA: Mt Atewa, primary forest with *Tetramorium* ants 1 ♀, 2.vi.1973 (*M. Edmunds*, vial 4) (BMNH); Kade, pyrethrum knock-down sample from a plot of Amelonado cocoa, 1 ♀, 21.iv.1971 (*J. D. Majer*) (BMNH).

*Myrmarachne mussungue* sp. n.

(Fig. 19D, E, G–J)

DIAGNOSIS. *Myrmarachne mussungue* is a long slender species (Fig. 19I) closely related to *M. insulana* Roewer from which it may be separated by the longer seminal ducts (Fig. 19D, G, H).

MALE. Unknown.

FEMALE. *Carapace* (Fig. 19I, E): finely punctured reticulate; light orange with white haired band in constriction. *Eyes*: anteriors contiguous with apices procurved, fringed with white hairs. *Clypeus*: sparsely fringed with light brown hairs. *Chelicerae*: finely rugulose; light orange, shiny; groove with 7 teeth on each margin. *Maxillae and Labium*: yellow-orange with inner distal margin of maxillae and labial tip paler. *Sternum* (Fig. 19J): light yellow-orange. *Abdomen* (Fig. 19I): whitish yellow with a darker streak anteriorly. *Legs*: slender, whitish yellow. Ventral spination of legs I: metatarsi 2–2, tibiae 1–2–2–2, patellae 0. *Epigyne* (Fig. 19D, G, H): lateral pouches more or less contiguous; spermathecae complex; proximal seminal duct moderately slender and clearly reaching beyond the lateral pouches.

*Dimensions*: total length 4.8–6.0 mm, carapace length 2.28–2.24 mm. *Ratios*: AM : AL : PM : PL : 10.5 : 5 : 1 : 5, AL–PM–PL : 6.5–5.6; a : 1.03–1.04, b : 1.04–1.06, c : 0.39–0.40, e : 0.80–0.84 (2 ♀ examined).

BIOLOGY. Unknown.

DISTRIBUTION. Angola.

MATERIAL EXAMINED. Holotype ♀, ANGOLA: Environs of Dundo, Source of R. Mussungue, collected with japanese umbrella, iii.1948 (*A. B. Machado*, Ang. 608.7) (MD, Dundo). Paratype ♀, Dundo 1953 (*A. B. Machado*, Ang. 11281.1) (BMNH).

ETYMOLOGY. The specific name is a noun in apposition taken from the region in which the holotype was collected.

*Myrmarachne evidens* Roewer

(Figs 20A, H, I; 21D, F, I; 22A, D)

*Myrmarachne evidens* Roewer, 1965 : 53, fig. 52, ♂. Holotype ♂, Zaire, Mauda (MRAC, Tervuren) [Examined]. Prószyński, 1971b : 437.

DIAGNOSIS. *M. evidens* is a very slender species characterized by the gentle thoracic slope (Figs 21D) and reduced flange (Fig. 22D). It is very closely related to *M. naro* sp. n. and *M. hesperia* Simon but may be distinguished by the shape and position of the flange (Fig. 22A, D).

FEMALE. Unknown.

MALE. *Carapace* (Figs 20A; 21D): finely punctured-reticulate; orange-brown with eye region lighter. *Eyes*: anteriors subcontiguous with apices procurved, fringed with whitish hairs. *Clypeus*: sparsely white haired. *Chelicerae* (Figs. 20I; 21F, I): rather slender; rugulose with furrows: orange-brown; fang apophysis present. *Maxillae and Labium*: light orange. *Sternum* (Fig. 20H): light orange. *Abdomen* (Figs 20A; 21D): yellow-brown; scuta light orange, the posterior one obscurely marked with a blackish chevron. *Legs*: slender; yellow-brown with metatarsi I brownish. Ventral spination of legs I: metatarsi 2–2, tibiae 2–2–2–2, patellae 0. *Palp* (Fig. 22A, D): tibial apophysis long and slender with distal hook; flange set midway along tibia and apparently reduced to a small lobe (i.e. in lateral view); basal ectal margin of cymbium depressed and fringed with stout setae.

*Dimensions*: total length 5.6–6.0 mm, carapace length 2.26–2.42 mm. *Ratios*: AM : AL :



PM:PL: 10.5 : 5 : 1 : 5; AL-PM-PL: 7-6.5; a: 1.05, b: 0.98, c: 0.38, d: 0.82-0.90, e: 0.80 (2♂ examined).

BIOLOGY. Unknown.

DISTRIBUTION. Zaire.

MATERIAL EXAMINED. Holotype ♂, data given in synonymy. Paratype ♂, ZAIRE, Abimva, vi.1925 (*H. Schouteden*, MT 31277) (MRAC, Tervuren).

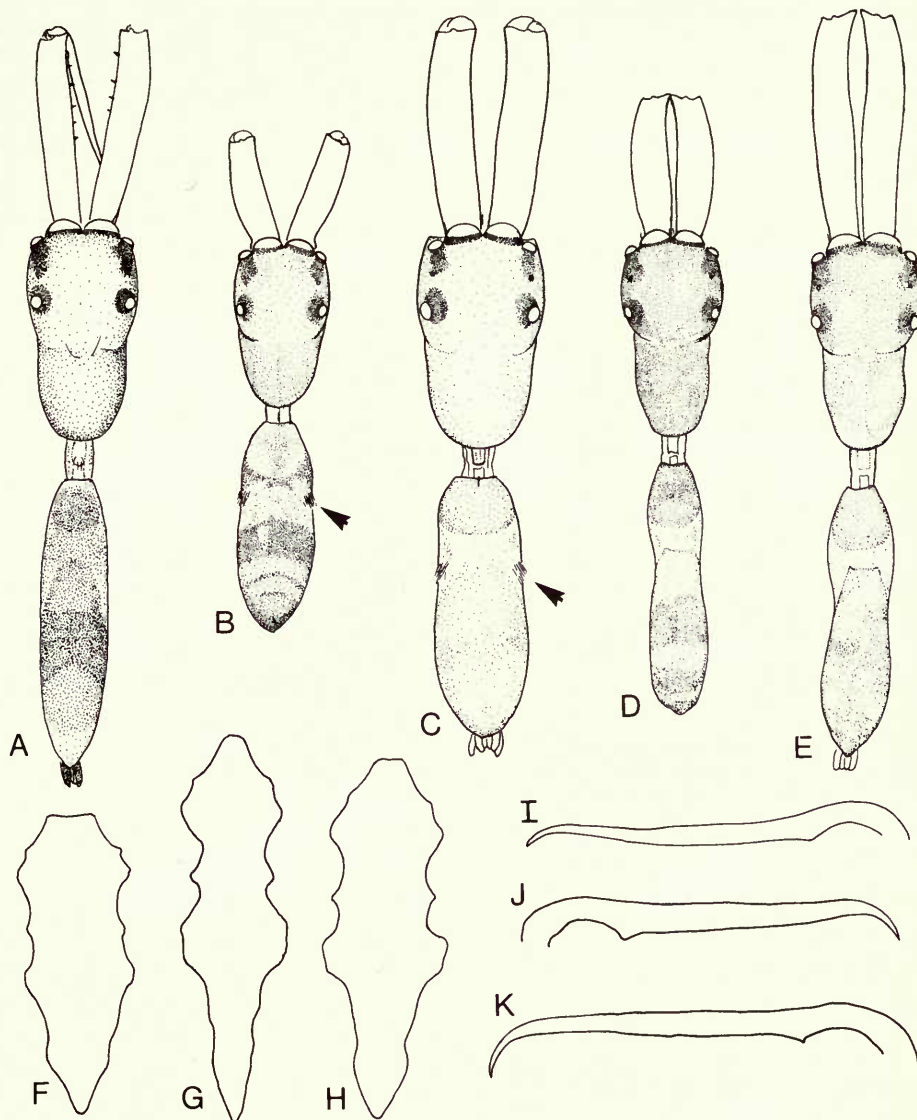

Fig. 20 (A, H, I) *Myrmarachne evidens* Roewer. Holotype ♂: (A) dorsal view; (H) sternum; (I) Fang. (B, C, F, K) *Myrmarachne nara* sp. n. Paratype ♂: (B) dorsal view. Holotype ♂: (C) dorsal view; (F) sternum; (K) fang. (D, E, G, J) *Myrmarachne hesperia* (Simon). ♂ from Ghana: (D) dorsal view; (G) sternum; (J) fang. Lectotype ♂: dorsal view.

*Myrmarachne nara* sp. n.

(Figs 20B, C, F, K; 21B, E, G, J; 22B, E, J)

DIAGNOSIS. *M. nara* is a slender species with little tufts of white hair in the abdominal constrict-

tion. It is very closely related to *M. hesperia* Simon and *M. evidens* Roewer but may be distinguished by the shape and position of the flange (Fig. 22E, G) and somewhat heavier carapace (Fig. 20B, C).

FEMALE. Unknown.

MALE. *Carapace* (Figs 20B, C; 21B, E): finely punctured-reticulate; yellowish orange with very scattered light brown hairs. *Eyes*: anteriors subcontiguous with apices procurved, fringed with whitish hairs. *Clypeus*: white haired. *Chelicerae* (Figs 20K; 21G, J): finely rugulose with furrows; yellow-brown with dark brown lateral keels, shiny; fang apophysis present. *Maxillae and Labium*: yellow-brown, shiny; labium a shade darker. *Sternum* (Fig. 20F): yellow-brown tinged with black. *Abdomen* (Figs 20B, C; 21B): yellow-brown tinged with black; scuta yellowish orange with brown-black bands; sparsely clothed with fine golden hairs with white haired tufts in constriction. *Legs*: slender; legs I tarsi light yellow-brown; metatarsi brown-black; remaining segments light yellow-brown but with blackish on sides of tibiae, patellae and femora. Legs II and III light yellow-brown. Legs IV as III but some darkening on femora, patellae and tibiae. Ventral spina-

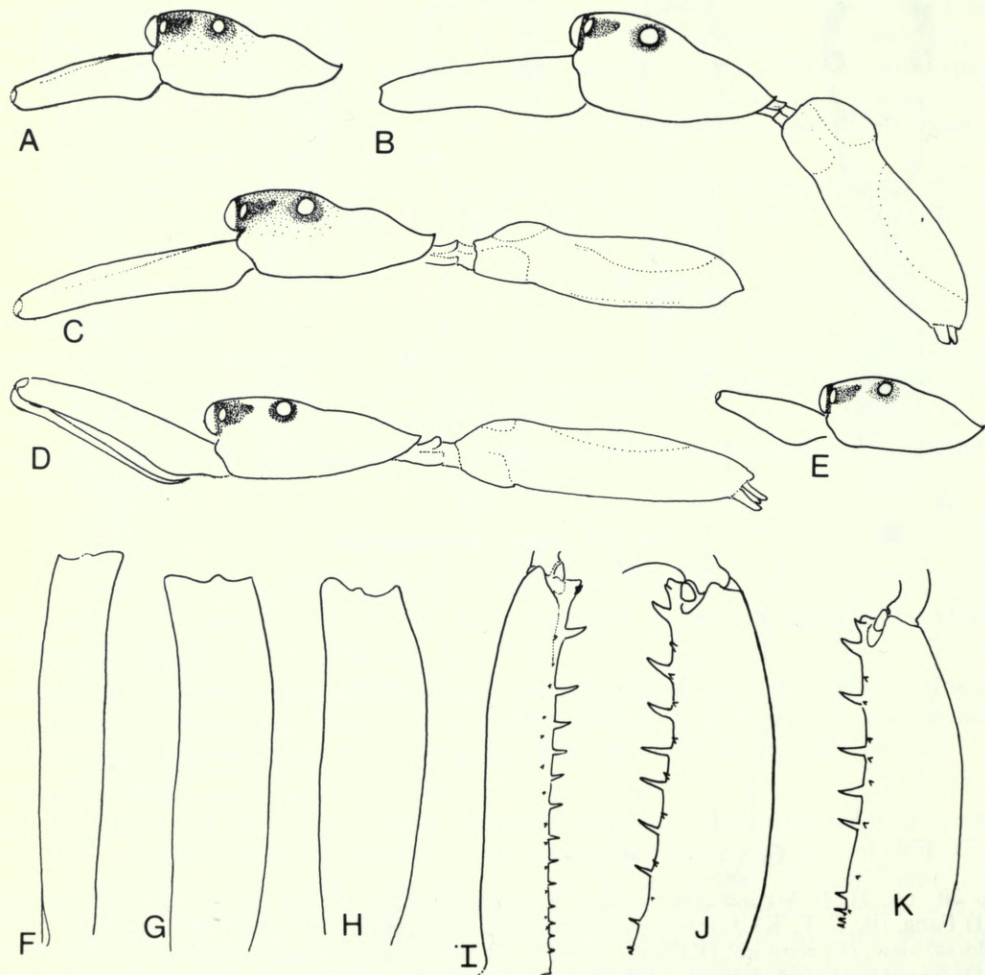

Fig. 21 (A, C, H, K) *Myrmarachne hesperia* (Simon). ♂ from Ghana: (A) carapace, lateral view; (H) chelicera, dorsal view; (K) chelicera, ventral view. Lectotype ♂: (C) lateral view. (B, E, G, J) *Myrmarachne naro* sp. n. Holotype ♂: (B) lateral view; (G) chelicera, dorsal view; (J) chelicera, ventral view. Paratype ♂: (E) carapace, lateral view. (D, F, I) *Myrmarachne evidens* Roewer. Holotype ♂: (D) lateral view; (F) chelicera dorsal view; (I) chelicera, ventral view.

tion of legs I: metatarsi 2-2, tibiae 2-2-1 or 2-2-2-2, patellae 0. *Palp* (Fig. 22B, E, G): tibial apophysis long and slender with distal hook; flange set, distally on tibiae, well developed; proximal ectal margin of cymbium depressed, fringed with stout setae.

*Dimensions*: total length 4.2-5.0 mm, carapace length 1.78-2.18 mm. *Ratios*: AM : AL : PM : PL : 7.5 : 4 : 1 : 4, AL-PM-PL : 5.5-5.5. a : 0.96-1.04, b : 1.0, c : 0.42, d : 0.61-0.97, e : 0.77-0.79 (2♂ examined).

**BIOLOGY.** Unknown.

**DISTRIBUTION.** Kenya.

**MATERIAL EXAMINED.** Holotype ♂ and paratype ♂, Kenya, Naro Moru, 2000 m, swept from bushes and vegetation by the side of the river, 17.viii.1974 (*J. & F. Murphy*, vial 4245) (BMNH, reg. no. 1977.4.21.32).

**ETYMOLOGY.** The specific name is a noun in apposition taken from the type-locality.

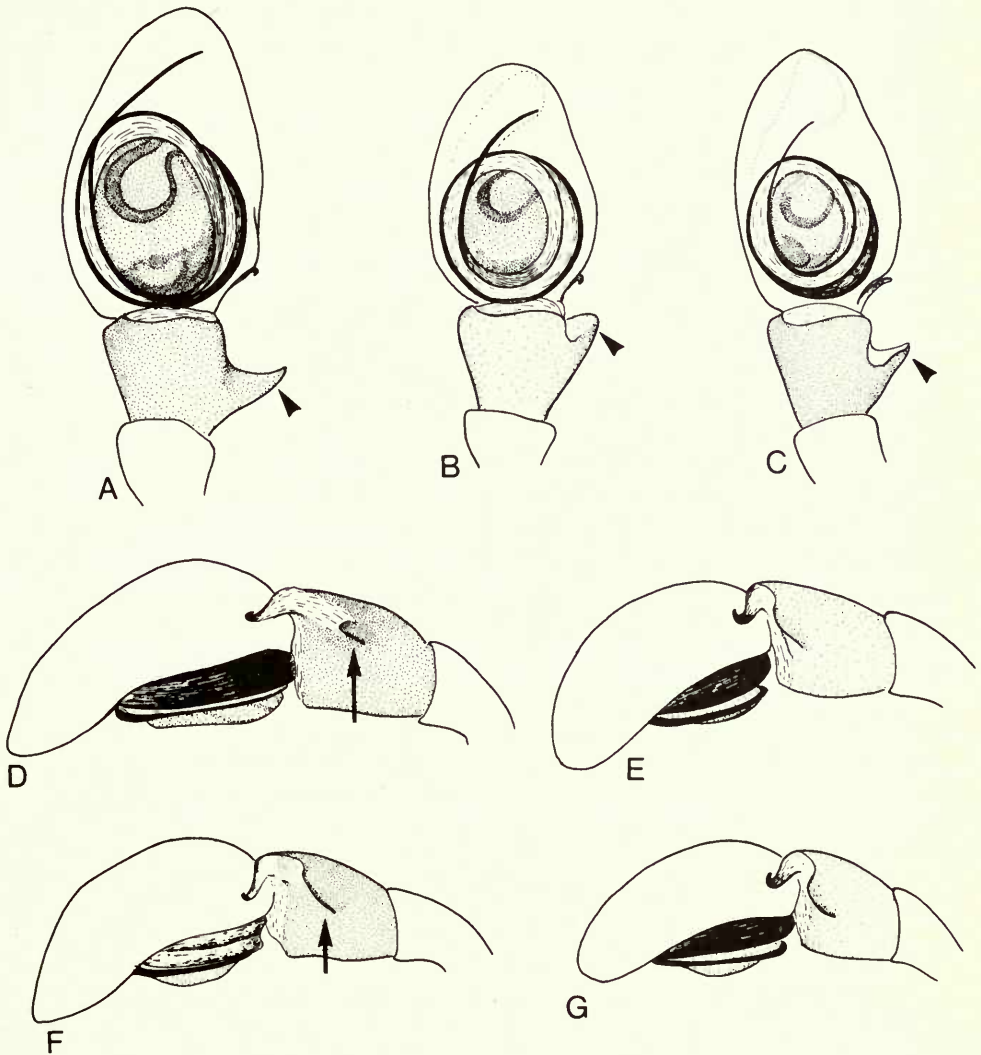

**Fig. 22** (A, D) *Myrmarachne evidens* Roewer. Holotype ♂: (A) palp, ventral view; (D) palp, lateral view. (B, E, G) *Myrmarachne naro* sp. n. Holotype ♂: (B) palp, ventral view; (E) palp, lateral view. Paratype ♂: (G) palp, lateral view. (C, F) *Myrmarachne hesperia* (Simon). ♂ from Ghana: (C) palp, ventral view; (F) palp, lateral view.



*Myrmarachne hesperia* (Simon)

(Figs 20D, E, G, J; 21A, C, H, K; 22C, F)

*Salticus hesperius* Simon, 1887 : 261, ♂. LECTOTYPE ♂ (here designated), Ivory Coast, Assinie (MNHN, Paris) [Examined].

*Myrmarachne hesperia* (Simon): Simon, 1901 : 498. Roewer, 1954 : 943. Bonnet, 1957 : 3006. Roewer, 1965 : 74, fig. 54.

[*Myrmarachne hesperius*: Fage 1927 : 636, ? Misidentification.]

*Myrmarachne chelata* Wanless & Clark, 1975 : 294, figs 36–43, ♂. Holotype ♂, Ivory Coast, Bingerville (MRAC, Tervuren) [Examined]. **Syn. n.**

From an examination of material in the Paris Museum it is apparent that Simon consistently misidentified *M. elongata* Szombathy as *M. hesperia* (Simon). Simon (1910) and Berland & Millot (1941) refer to *M. elongata* but the identity of the specimens examined by Fage (1927) is uncertain. Roewer (1965) examined the type-specimen of *M. hesperia* (Simon) but did not comment on its affinities and evidently did not make comparisons with other specimens in the Simon collection but merely listed locality records of Simon and Berland & Millot.

DIAGNOSIS. *M. hesperia* is a long, slender species, very closely related to *M. evidens* Roewer and *M. naro* sp. n. but may be distinguished by the weak, ventral scutum and position of the flange (Fig. 22F). It resembles in general body form *M. elongata* but is readily distinguished by the structure of the palp.

FEMALE. Unknown but could belong with *M. insulana* Roewer.

MALE. *Carapace* (Fig. 20D, E; 21A, C): punctured-reticulate; orange-brown; sparsely clothed with white hairs forming very scanty, transverse bands on thoracic part with white wedge-shaped bands in constriction. *Eyes*: anteriors contiguous with apices procurved, fringed with white hairs. *Clypeus*: white haired. *Chelicerae* (Figs 20J; 21H, K): rugulose with furrows; orange-brown with blackish lateral keels; fang apophysis present. *Maxillae and Labium*: orange-brown tinged with some black, labium sometimes darker. *Sternum* (Fig. 20G): light orange-brown tinged with black. *Abdomen* (Figs 20D, E; 21C): mottled yellow-brown and black; dorsal scuta dark orange-brown tinged with some black with blackish markings; ventral scutum rather weak, orange-brown. *Legs*: slender; legs I yellow-brown with metatarsi and sides of femora blackish. Legs II yellow-brown. Legs III yellow-brown but sides of femora, trochanters and coxae blackish. Legs IV as III but patellae marked with blackish. Ventral spination of legs I: metatarsi 2–2, tibiae 2–2–2–2, patellae 0. Femoral spines lacking. *Palp* (Fig. 22C, F): tibial apophysis long, slender and distally hooked; flange well developed, positioned medially; proximal depression fringed with stout setae.

*Dimensions*: total length 5.40–6.2 mm, carapace length 2.10–2.4 mm. *Ratios*: AM : AL : PM : PL : 10 : 5 : 1 : 5, AL–PM–PL : 6–6.4; a : 1.02–1.04, b : 1.0–1.04, c : 0.37–0.41, d : 0.76–0.90, e : 0.73–0.78 (5♂ examined).

BIOLOGY. Unknown.

DISTRIBUTION. Ivory Coast, Ghana.

MATERIAL EXAMINED. Type data given in synonymy. GHANA: Tafa, pyrethrum knockdown, 3♂, ix.1966 (*Gibbs*) (BMNH).

*Myrmarachne confusus* sp. n.

(Fig. 23A–H)

The holotype of this species was labelled '*Myrmarachne nexilis*' by Simon and it is possibly the paralectotype of that species.

DIAGNOSIS. *Myrmarachne confusus* clearly shows affinities with *M. evidens* Roewer and *M. hesperia* (Simon) but is easily distinguished by the club-shaped chelicerae (Fig. 23C).

FEMALE. Unknown.

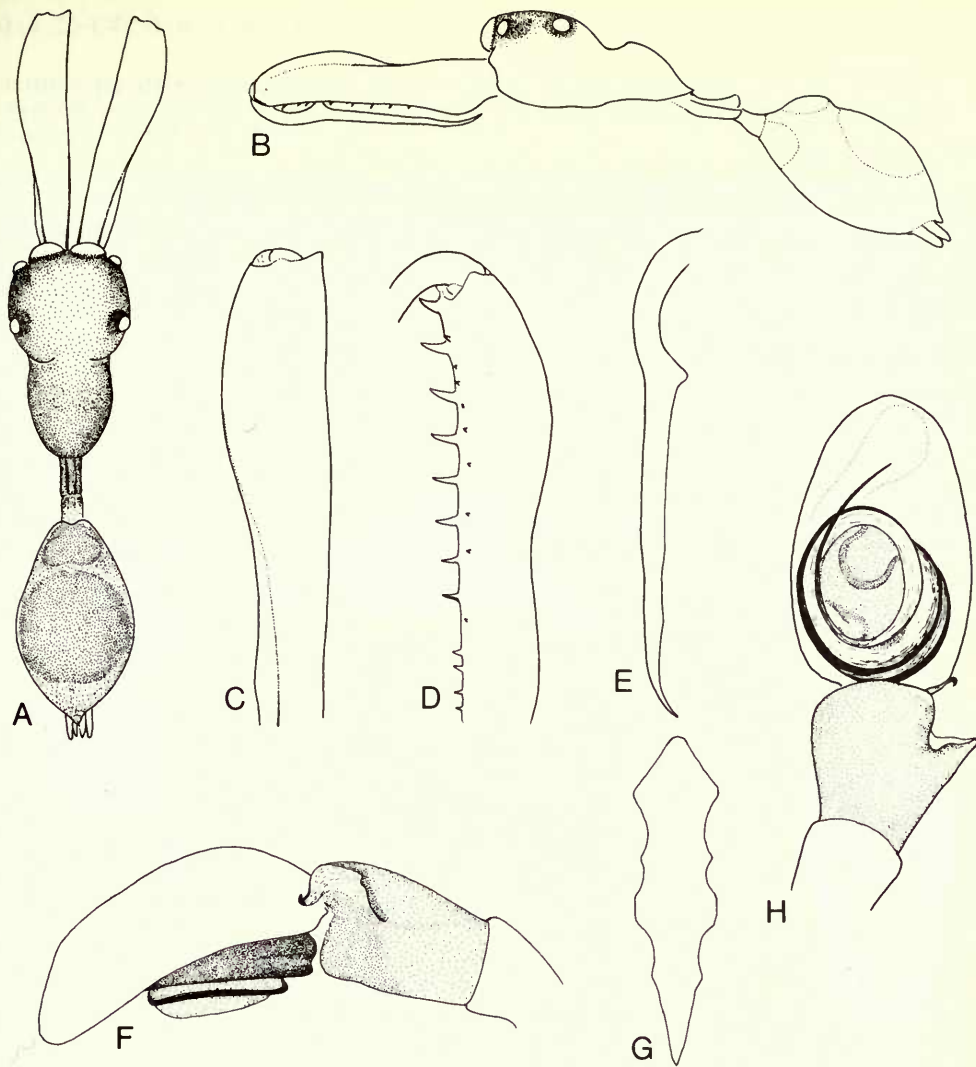

**Fig. 23** *Myrmarachne confusus* sp. n. Holotype ♂: (A) dorsal view; (B) lateral view; (C) chelicera, dorsal view; (D) chelicera, ventral view; (E) fang; (F) palp, lateral view; (G) sternum; (H) palp, ventral view.

**MALE.** *Carapace* (Fig. 23A, B): punctured-reticulate; orange-brown with white, wedge-shaped bands in constriction and very scanty, transverse, white haired bands on thoracic part. *Eyes*: anteriors subcontiguous with apices procurved, fringed with white hairs. *Clypeus*: white haired. *Chelicerae* (Fig. 23C, D, E): rugulose with furrows; dark reddish brown; fang apophysis present. *Maxillae and Labium*: orange-brown, labium darker. *Sternum* (Fig. 23G): orange-brown. *Abdomen* (Fig. 23A, B): mottled yellow-brown and black; scuta orange-brown tinged with black, shiny with fine scattered hairs. *Legs*: slender; legs I tarsi yellow-brown; metatarsi yellow-brown tinged with black; tibiae, patellae femora and trochanters yellow-brown with blackish sides; coxae orange-brown. Legs II yellow-brown but inside of femora blackish and coxae orange-brown. Legs III orange-brown grading to yellow-brown on distal segments. Legs IV as III but patellae, trochanters and coxae marked with yellowish. Ventral spination of legs I: metatarsi 2-2, tibiae 2-2-2-2, patellae 0. *Palp* (Fig. 23F, H): slightly variable and not distinguishable with certainty from *M. hesperia*.

*Dimensions*: total length 4.76-4.9 mm, carapace length 1.96-2.2 mm. *Ratios*: AM : AL :

PM : PL : 11 : 5 : 1 : 5, AL-PM-PL: 5.5-5.5; a: 1.03, b: 1.02, c: 0.38-0.39, d: 0.64-1.01, e: 0.71-0.74 (2♂ examined).

A male from Angola has a more slender body form the chelicera are relatively shorter (i.e. ratio d) and the flange is set slightly further back on the tibiae.

BIOLOGY. Unknown.

DISTRIBUTION. Angola, São Thomé.

MATERIAL EXAMINED. Holotype ♂, SÃO THOMÉ (MNHN, Paris). Paratype ♂, ANGOLA Parque Carrisso, 10.ix.1960 (A. B. Machado, Ang. 15655) (BMNH).

ETYMOLOGY. The specific name refers to the fact that the holotype was formally confused with *M. nexilis* in the Simon collection, Paris (see *B. nexilis* p. 9).

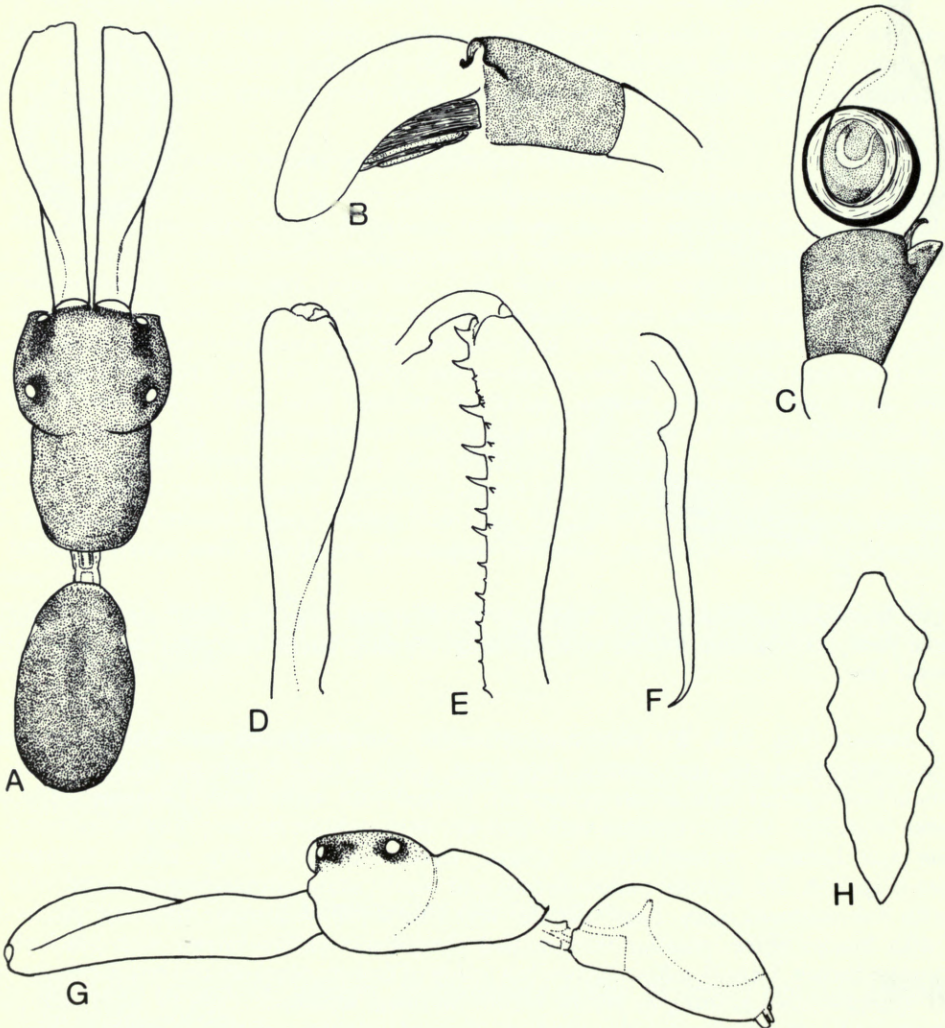

Fig. 24 *Myrmarachne collarti* Roewer. Holotype ♂: (A) dorsal view; (B) palp, lateral view; (C) palp, ventral view; (D) chelicera dorsal view; (E) chelicera ventral view; (F) fang; (G) lateral view; (H) sternum.



*Myrmarachne collarti* Roewer

(Fig. 24A-H)

*Myrmarachne collarti* Roewer, 1965 : 54, fig. 55, ♂. Holotype ♂, Zaire, Stanleyville (MRAC, Tervuren) [Examined]. Prószynski, 1971b : 437.

**DIAGNOSIS.** *Myrmarachne collarti* is a species of uncertain affinities. It resembles *M. confusus* sp. n. in body form and cheliceral shape but can be readily separated by the structure of the palp (Fig. 24B, C).

**FEMALE.** Unknown.

**MALE.** *Carapace* (Fig. 24A, G): punctured-reticulate; brown-black with a violet sheen and whitish, wedge-shaped bands in constriction; sparsely clothed with fine whitish hairs. *Eyes*: anterior subcontiguous with apices procurved, fringed with white hairs. *Clypeus*: white haired. *Chelicerae* (Fig. 24D, E, F): finely rugulose with furrows; brown-black; fang apophysis present. *Maxillae and Labium*: brown-black but inner margin of maxillae and labial tip paler. *Sternum* (Fig. 24H): dark orange-brown. *Abdomen* (Fig. 24A, G): mottled orange-brown and black; scuta contiguous, dark mahogany, sparsely clothed with fine whitish hairs. *Legs*: slender; legs I tarsi and metatarsi dark brownish orange; tibiae and patellae light orange-brown with blackish sides; remaining segments dark brownish orange. Legs II similar to I but tarsi and metatarsi light orange-brown. Legs III tarsi and metatarsi light orange-brown; other segments orange-brown. Legs IV as III but trochanters and patellae marked with yellow-brown. Ventral spination

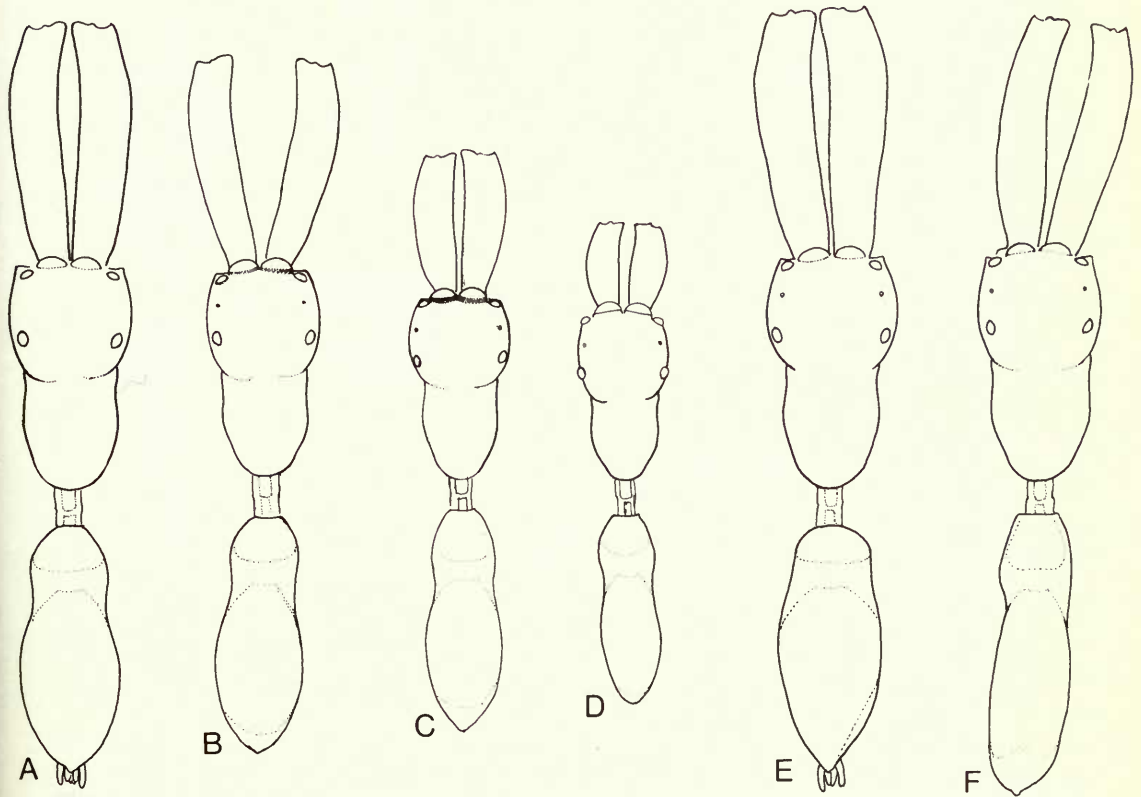

**Fig. 25** *Myrmarachne elongata* Szombathy, drawn to scale. (A-D) 4 males, showing allometric growth, from a series of 11 males from Sierra Leone. (E) ♂ from Ivory Coast misidentified as *M. hesperia* (Simon) by Berland & Millot (1941 : 407). (F) holotype ♂ of *M. coppeti* Berland & Millot.

of legs I: metatarsi 2-2, tibiae 2-2-2-2, patellae 0. *Palp* (Fig. 24B, C): tibial apophysis slender, distally hooked; flange relatively small; proximal depression fringed with stout setae.

*Dimensions*: total length 5.4 mm (abdomen of holotype missing), carapace length 2.24-2.68 mm. *Ratios*: AM : AL : PM : PL : 10 : 5 : 2 : 5; a: 0.82-0.93, b: 0.92-1.0, c: 0.38-0.40, d: 1.10-1.26, e: 0.74 (2♂ examined).

**BIOLOGY.** The holotype was accompanied by an ant *Odontomachus troglodytes* Santschi, an open woodland and savanna species, widespread in West and Central Africa.

**DISTRIBUTION.** Uganda, Zaire.

**MATERIAL EXAMINED.** Holotype ♂, data given in synonymy. UGANDA: Bugalla Isle, Lake Victoria 1♂, xii.1912 (*G. D. H. Carpenter*) (BMNH).

*Myrmarachne elongata* Szombathy

(Figs 25A-F; 26A-H; 27A-I; 28A-I)

[*Myrmarachne hesperius* (Simon): Simon, 1910 : 414, unjustified emendation. Misidentification.]

*Myrmarachne elongata* Szombathy, 1915 : 475, fig. 6, ♂. LECTOTYPE ♂ (here designated), Uganda, Mujenji (TM, Budapest) [Examined]. Roewer, 1954 : 942. Bonnet, 1957 : 3001. Roewer, 1965 : 45, fig. 34. Prószyński, 1971b : 437.

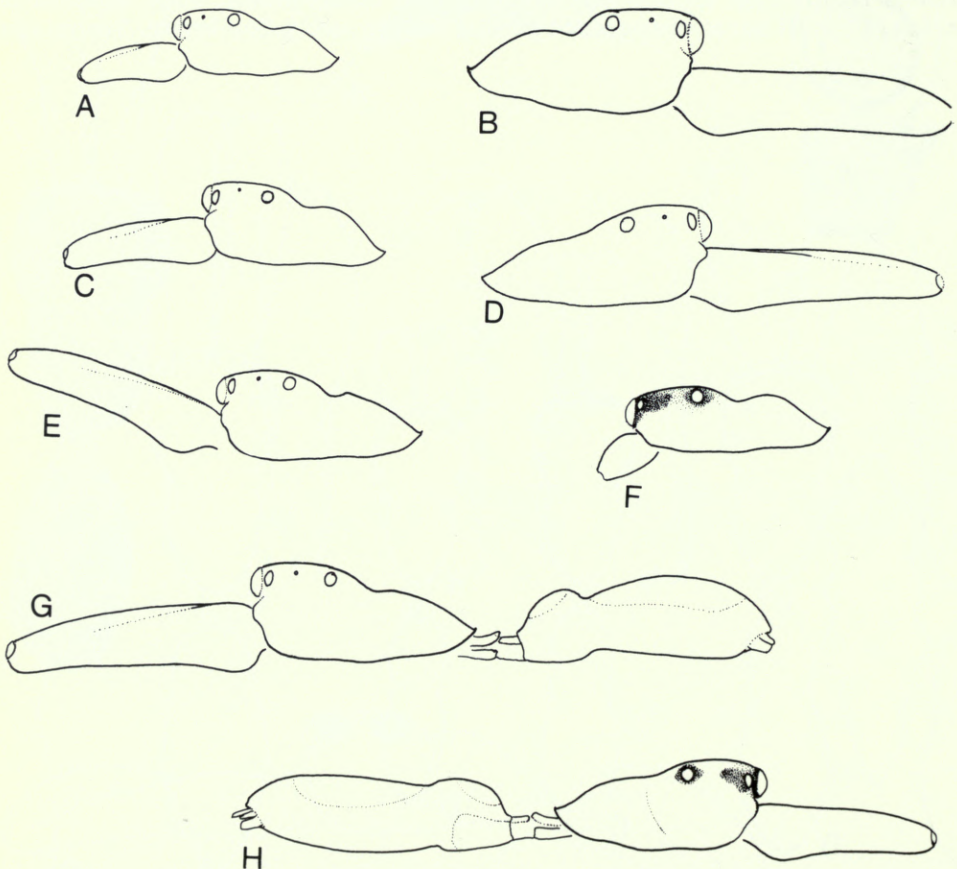

**Fig. 26** *Myrmarachne elongata* Szombathy, drawn to scale. (A, C, E, G) 4 males, showing allometric growth, from a series of 11 males from Sierra Leone. (B) ♂ from Ivory Coast, misidentified as *M. hesperia* (Simon) by Berland & Millot (1941 : 407). (D) holotype ♂ of *M. coppeti* Berland & Millot. ♀ from Ibadan: (F) carapace, lateral view. Lectotype ♂: (G) lateral view. Lectotype ♂: (H) lateral view.

*Myrmarachne coppeti* Berland & Millot, 1941 : 405, figs 95, 101, ♂. Holotype ♂, Senegal, Dakar (MNHN, Paris) [Examined]. Roewer, 1954 : 942; 1695 : 73, fig. 53. **Syn. n.**  
 [Myrmarachne hesperia (Simon): Berland & Millot, 1941 : 407, fig. 97. Misidentification.]  
*Myrmarachne faradjensis* Roewer, 1965 : 48, fig. 36, ♂. Holotype ♂, Zaire, Faradje (MRAC, Tervuren) [Examined]. Prószyński, 1971b : 437. **Syn. n.**  
*Myrmarachne atra* Roewer, 1965 : 50, fig. 40, ♂. Holotype ♂, Zaire, Tembwe (MRAC, Tervuren) [Examined]. Prószyński, 1971b : 436. **Syn. n.**  
*Myrmarachne abimvai* Roewer, 1965 : 58, figs 61, 61a, ♂, ♀. Holotype ♂, Zaire, Abimva (MRAC, Tervuren) [Examined]. Prószyński, 1971b : 436. **Syn. n.**  
*Myrmarachne dartavellei* Roewer, 1965 : 58, fig. 62, ♂. Holotype ♂, Zaire, Matadi (MRAC, Tervuren) [Examined]. Prószyński, 1971b : 438. **Syn. n.**  
*Myrmarachne kasaia* Roewer, 1965 : 60, fig. 64, ♂. Holotype ♂, Zaire, Kasai S., Tshisika (MRAC, Tervuren) [Examined]. Prószyński, 1971b : 438. **Syn. n.**  
*Myrmarachne moto* Roewer, 1965 : 60, fig. 65, 65a, ♂, ♀. Holotype ♂, Zaire, Moto (MRAC, Tervuren) [Examined]. Prószyński, 1971b : 439. **Syn. n.**

*Myrmarachne elongata* Szombathy is the first available name for this variable and widespread species. Judging from material in the Paris Museum, Simon consistently misidentified *M. elongata* Szombathy as *M. hesperia* (Simon), a morphologically similar but nevertheless distinct species.

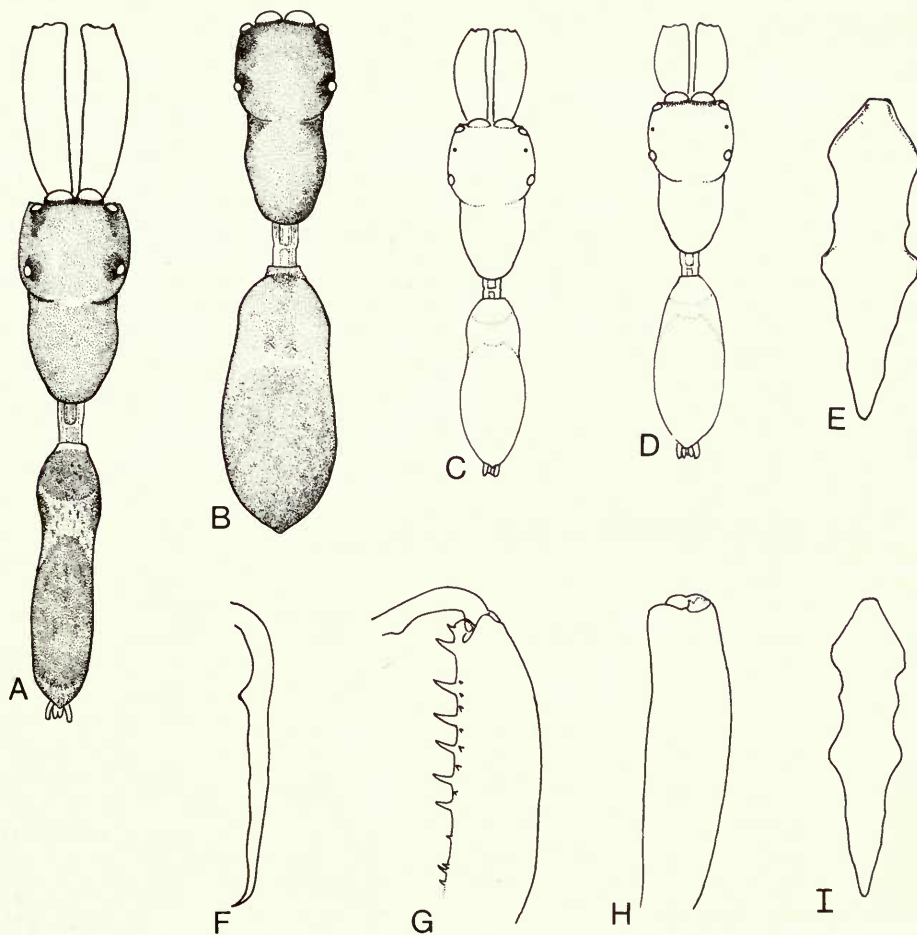

**Fig. 27** *Myrmarachne elongata* Szombathy. Lectotype ♂: (A) dorsal view; (E) sternum; (F) fang; (G) chelicera, ventral view; (H) chelicera, dorsal view. ♀ from Ibadan: (B) dorsal view; (I) sternum. (C, D) dwarf males from Ghana, collected on different dates but from the same locality (i.e. tree).



Evidently Berland & Millot (1941) did not examine the type of *hesperia* because they too misidentified this species.

Roewer (1965) did not see the type of *elongata* but he proposed 6 new species which were separated by trivial characters (i.e. cheliceral length, state of abdominal constriction and number of ventral tibial spines on legs I) that are variable and of unreliable diagnostic value. Some of the male holotypes are in poor condition but all 6 species are considered to be conspecific with *elongata*. The paratype female of *M. abimva* Roewer certainly represents a new taxon but it is in poor condition and not described in this paper. Of two paratype females described under *M. moto* Roewer, one is conspecific with *elongata* and the other with *M. kiboschensis* Lessert.

**DIAGNOSIS.** *M. elongata* is a slender, elongate species which shows wide variations in size. It is distinguished from most other elongate species (i.e. *M. evidens* Roewer, *M. hesperia* (Simon) and *M. insulana* Roewer by the genitalia (Fig. 28A–I) and from the yellowish orange *M. ichneumon* (Simon) by its brown-black colour. It is closely related to *M. lulengensis* Roewer from which it is doubtfully separated by the palpal tibia (Fig. 28B–E) and by having the posterior part of the thorax more attenuate. Very small specimens (i.e. dwarf forms) may be confused with other, less slender, species which also exhibit dwarfism (i.e. *M. marshalli* Peckham & Peckham and *M. legon* sp. n.). However, *elongata* is separated by the more slender abdomen, scattered white hairs on the thorax, the three light-coloured spots on the cephalic part and dorsal femoral spines.

**MALE.** *Carapace* (Figs 25A–F; 26A–E, G, H; 27A, C, D): punctured-reticulate brown-black, usually with three light orange patches in constriction; sparsely clothed with white hairs with white, wedge-shaped bands in constriction. *Eyes*: anterior subcontiguous with apices procurved, fringed with white hairs. *Clypeus*: white haired. *Chelicerae* (Fig. 27F, H): rugulose with furrows; orange-brown with blackish lateral keels; fang apophysis pronounced but less well developed in small specimens. *Maxillae and Labium*: yellow-brown suffused with black, labium sometimes darker. *Sternum* (Fig. 27E): orange-brown tinged with black. *Abdomen* (Figs 25A–F; 26G, H; 27A): mottled yellow-brown and black; scuta dark orange suffused with black; sparsely fringed with fine, whitish hairs. *Legs*: slender, legs I yellow-brown but tarsi and metatarsi tinged with black, with sooty streaks on sides of tibiae and patellae and on insides of femora, trochanters and coxae. Legs II similar to I but tarsi and metatarsi yellow-brown with sooty markings on outside of trochanters and coxae. Legs III orange-brown suffused with black but tibiae, metatarsi and tarsi yellow-brown. Legs IV as III but coxae, trochanters and patellae marked with light yellowish. Ventral spination of legs I: metatarsi 2–2, tibiae, usually 2–2–2–2, patellae 0. Femora usually with one or two dorsal or dorsolateral spines. *Palp* (Fig. 28A–E): tibiae variable in shape; tibial apophysis distally hooked. Flange moderately well developed; proximal depression fringed with stout setae.

*Dimensions*: total length 3.84–6.08 mm, carapace length 1.76–2.58 mm. *Ratios*: AM : AL : PM : PL : 9 : 4 : 1.2 : 4.5, AL–PM–PL: 5.5–7.5; a: 0.90–1.02, b: 0.92–1.02, c: 0.36–0.39, d: 0.47–1.12, e: 0.59–0.74 (10♂ examined).

**FEMALE.** *Carapace* (Figs 26F; 27B): punctured-reticulate; brown-black with scattered white hairs and white, wedge-shaped bands in constriction. *Eyes*: more or less as in ♂. *Clypeus*: fringed with light brownish hairs. *Chelicerae*: rugulose; light orange, shiny; promargin with 6 or 7 teeth, retromargin with 7 or 8. *Maxillae and Labium*: as in ♂. *Sternum*: as in ♂. *Abdomen* (Fig. 27B): yellow-brown suffused with black with a brownish patch anteriorly; clothed with fine, light brownish hairs with oblique, yellowish bands on the sides. *Legs*: slender; legs I tarsi and metatarsi yellow-brown tinged with black; tibiae and patellae yellow-brown with black streaks along the sides; femora light yellowish with black streaks outside and proximal streaks inside; trochanters and coxae light yellowish but with black streaks inside. Legs II as I but tarsi and metatarsi yellow-brown, femora with black distal streak only; trochanters and coxae light yellow but with blackish spot on coxae (sometimes lacking). Legs III orange-brown tinged with black but tarsi and metatarsi yellow-brown. Legs IV as III but metatarsi orange-brown, patellae and trochanters marked with yellowish. Ventral spination of legs I as in ♂ but femoral spines lacking. *Epigyne* (Fig. 28F–I): usually indistinct; lateral pouches small and separate; spermathecae simple,

basic figure eight configuration but orientation slightly variable and configuration not always obvious.

*Dimensions*: total length 5.16–5.8 mm, carapace length 2.24–2.42 mm. *Ratios*: AM : AL : PM : PL : 8 : 4 : 1 : 4, AL-PM-PL : 5.5–6.5; a : 1.02, b : 1.02–1.04, c : 0.35–0.37, e : 0.66–0.71 (10 ♀ examined).

Allometric growth is particularly well marked in males of this species, larger individuals having relatively larger chelicerae (Figs 25A–F; 26A–E, G, H) and lower values for ratios a and b. A series of males from Ghana shows individual variation in cheliceral shape (Fig. 27C, D) but the extent of individual variation among specimens of equal size cannot be adequately demonstrated from the samples at hand, although the forms described as *M. coppeti* Berland & Millot and *M. hesperia* (Simon) sensu Berland & Millot (1941) suggest that considerable variation in carapace shape will occur (Fig. 26B, D).

**BIOLOGY.** In Nigeria, frequent on shrubs and trees in fallow bush and secondary forest. Females are sometimes found spun-up in a small silken retreat in the fold of a leaf (A. Russell-Smith, pers. comm.).

Immatures and females are preyed upon by sphecid wasps. A sphecid nest of several cells collected in Ibadan, Nigeria, contained 26 immature specimens and 3 females of *M. elongata*.

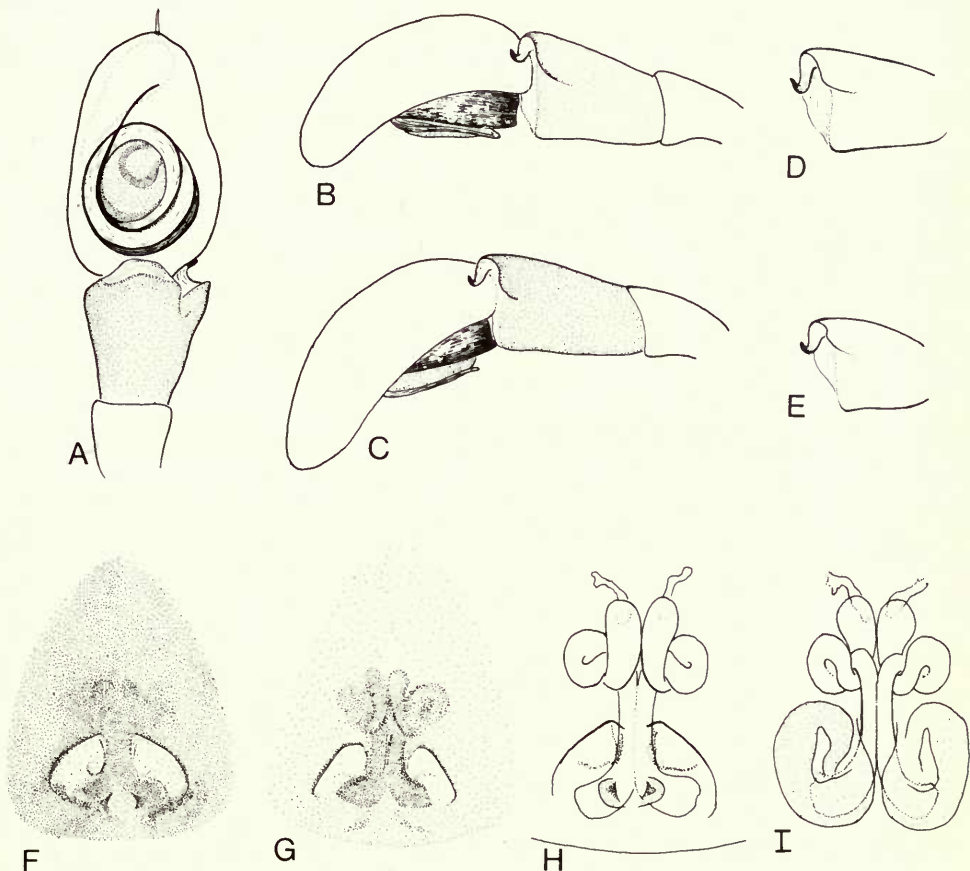

**Fig. 28** *Myrmarachne elongata* Szombathy. Lectotype ♂: (A) palp, ventral view; (B) palp, lateral view. Holotype ♂ of *M. coppeti* Berland & Millot: (C) palp, lateral view. Males from Sierra Leone: (D) palpal tibiae from large ♂; (E) palpal tibiae from small ♂, drawn to scale. Females from Ibadan: (F) epigyne, ventral view; (G) epigyne of another specimen; (H) vulva, ventral view; (I) vulva, dorsal view.

Provisional studies on numerous *Pison* cells, collected by M. Edmunds in Ghana, shows that immatures and female *elongata* are heavily preyed upon, as most cells contained numerous specimens. Other genera also represented in the *Pison* nests included *Pseudicus*, *Telamonia* and *Cosmophasis*.

DISTRIBUTION. Angola, Ghana, Ivory Coast, Nigeria, São Thomé, Senegal, Sierra Leone, Uganda, Zaire.

MATERIAL EXAMINED. Type-data given in synonymy. ANGOLA: Dundo, in house at night time, 1♂, x.1948 (*A. B. Machado*, Ang. 1218); 1♂, x.1962 (*A. B. Machado*, Ang. 18155); Alto Cuflo, R. Cavuembal, with Japanese umbrella, 1♀, 4.vi.1954 (*A. B. Machado*, Ang. 4100.11) (BMNH). GHANA: Tafa, pyrethrum knockdown, 4♂, 5-9.ix.1966 (*Gibbs*); Bibiani, 1♂ (*H. Spurrell*); Legon, 1♂, 1973 (*M. Edmunds*, vial 3); Legon, with *Tetraponera anthracina* Santschi, 3♂, xi-i.1972/73 (*M. Edmunds*, vial 39) (BMNH). IVORY COAST: Danane, 1♂, viii.1937 (*J. Millot*); Man, 1♂ (*Berland & Millot*) (MNHN, Paris). NIGERIA: Ibadan, International Institute of Tropical Agriculture, Centre for Overseas Pest Research site (*A. Russell-Smith*), 2♀, 9.vi.71; 2♀, 18.iii.1974; 1♀, 13.vi.1973; fallow bush, 2♂, 28.viii.1974, 1♂, 3.ii.1974; secondary forest, 2♂, 10.xi.1974; in sphecid nest, 4♀, 22 immatures, 3.vi.1974 (BMNH). SÃO THOMÉ: North Coast, litter in savanna with baobab trees, 1♂, 8-10.x.1973 (*G. Schmitz*, MT 146337); Ecole Mesquita, 10 km from São Thomé, 100 m, 1♀, 10.xi.1973 (*G. Schmitz*, MT 146336) (MRAC, Tervuren). SIERRA LEONE: Freetown, 2♀, 11♂ (*A. Mocqueries*) (MNHN, Paris). UGANDA: Kampala, 1♂, 5.xii.1922 (BMNH). ZAIRE: Basongo, 1♂, vii.1927 (*H. Schouteden*, MT 31258); Bas-Congo, Singa-Kazu, 1♂, 26.ii.1924 (*J. Collart*, MT 130.767); Kasongo, 1♂, viii.1959 (*P. L. G. Benoit*, MT 114985) (MRAC, Tervuren).

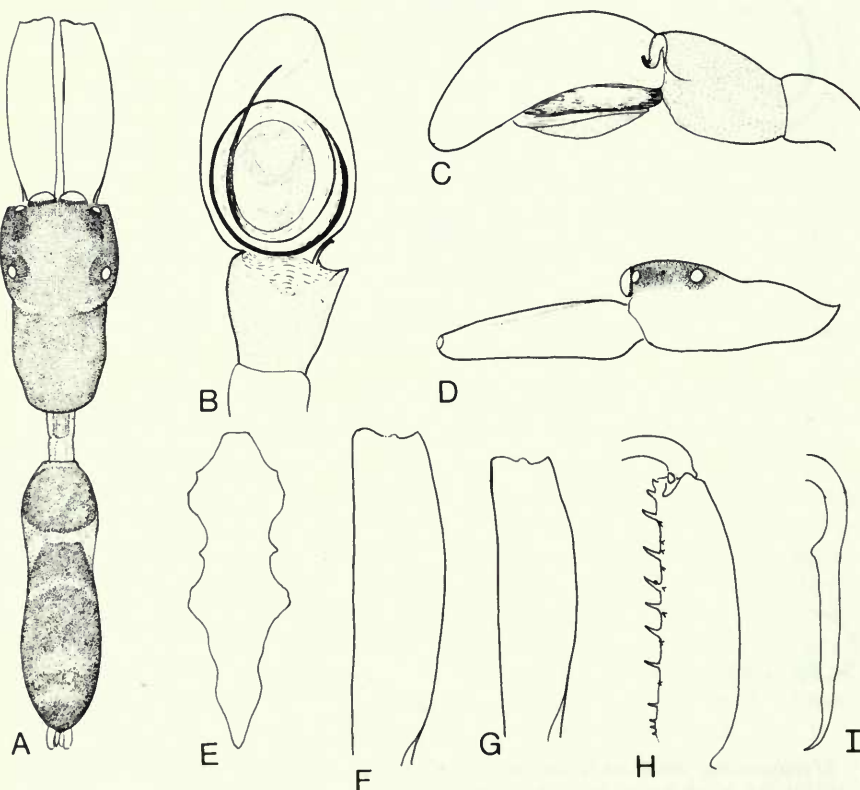

Fig. 29 *Myrmarachne lulengensis* Roewer. Holotype ♂: (A) dorsal view; (B) palp, ventral view; (C) palp, lateral view; (D) lateral view; (E) sternum; (G) chelicera, dorsal view; (H) chelicera ventral view; (I) fang. Holotype ♂ of *M. caheni* Roewer: (F) chelicera, dorsal view.



*Myrmarachne lulengensis* Roewer

(Fig. 29A-I)

*Myrmarachne lulengensis* Roewer, 1965 : 49, fig. 39, ♂. Holotype ♂, Zaire, Lulenga (MRAC, Tervuren) [Examined]. Prószyński, 1971b : 439.

*Myrmarachne caheni* Roewer, 1965 : 61, fig. 67, ♂. Holotype ♂, Zaire, Boma (MRAC, Tervuren) [Examined]. Prószyński, 1971b : 437. Syn. n.

The type-specimens of *M. lulengensis* and *M. caheni* are in poor condition, the abdomen of *lulengensis* is damaged and that of *caheni* is missing. A female abdomen in with the holotype of *caheni* belongs to *M. foenisex* Simon. Two other males from Zaire also have distorted abdomens and it is possible that the abdomen is broader than I have indicated in Fig. 29A.

DIAGNOSIS. *M. lulengensis* closely resembles *M. elongata* but the posterior part of the carapace is slightly more truncate and the inner keels of the chelicerae are straighter (Fig. 29F, G). The tibiae of the palps, when compared with equal-sized palps of *elongata*, are relatively shorter with the dorsal and ventral surfaces more curved; also the diameter of the tegulum and embolus is greater in relation to the cymbium (Fig. 29B). The distinction is, however, less evident when a comparison is made with the palps from smaller specimens of *elongata*. *M. lulengensis* appears to be a good species but it could equally well be a variant of *elongata*. Further collections from Zaire are needed to reach a satisfactory conclusion.

FEMALE. Unknown.

MALE. *Carapace* (Fig. 29A, D): punctured-reticulate; blackish orange with three light orange patches in constriction; sparsely clothed with whitish hairs with white, wedge-shaped bands in constriction. *Eyes*: subcontiguous with apices procurved, fringed with white hairs. *Clypeus*: white haired. *Chelicerae* (Fig. 29F-I): rugulose with furrows; orange-brown with blackish lateral keels; fang apophysis present. *Maxillae and Labium*: orange-brown tinged with black but inner margins of maxillae lighter; labium sometimes darker with paler tip. *Sternum* (Fig. 29E): orange-brown tinged with black. *Abdomen* (Fig. 29A): mottled yellow-brown and black with shiny dark red-brown scuta; behind constriction a scanty, transverse, white-haired band. *Legs*: slender; legs I light orange-brown with dark brown metatarsi and sooty streaks along inside of tibiae and patellae. Legs II orange-brown. Legs III light orange-brown tinged with blackish. Legs IV as III but trochanters and patellae marked with yellowish. Ventral spination of legs I: metatarsi 2-2, tibiae 2-2-2, patellae 0 or 1. Femora with one or two dorsal or dorsolateral spines. *Palp* (Fig. 29B, C): tibial apophysis distally hooked; flange moderately well developed; proximal depression fringed with slender setae.

*Dimensions*: total length 6.0-6.4 mm, carapace length 2.28-2.72 mm. *Ratios*: AM : AL : PM : PL: 8.5 : 4 : 1 : 4.2, AL-PM-PL: 6.5-7; a: 0.84-0.90, b: 0.93-0.96, c: 0.36-0.38, d: 0.69-0.92, e: 0.66-0.71 (4♂ examined).

BIOLOGY. Unknown.

DISTRIBUTION. Zaire.

MATERIAL EXAMINED. Type-data given in synonymy. ZAIRE: Nioka, 2♂, xii.1952 (*J. Hecq*, MT 74474-5) (MRAC, Tervuren).

*Myrmarachne rufisquei* Berland & Millot

(Fig. 30A-C)

*Myrmarachne rufisquei* Berland & Millot, 1941 : 411, figs 100, 101, ♂. Holotype ♂, Senegal, near Dakar (MNHN, Paris) [Examined, in part]. Roewer, 1954 : 944; 1965 : 72, fig. 49.

All that remains of the holotype is the left palp and the description given below is based on the original given by Berland & Millot (1941).

DIAGNOSIS. *M. rufisquei* is a distinctive species closely related to *M. elongata* Szombathy but can be readily separated by the dark submarginal bands on the thorax (Fig. 30A).

FEMALE. Unknown.

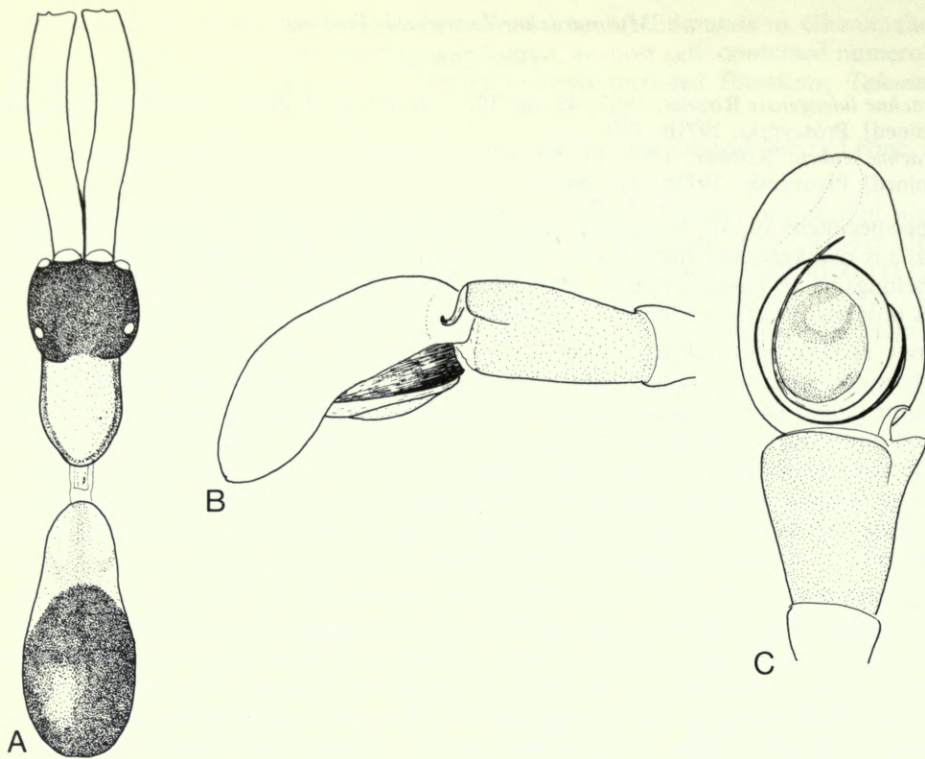

Fig. 30 *Myrmarachne rufisquei* Berland & Millot. Holotype ♂: (A) dorsal view (after Berland & Millot, 1941); (B) palp, lateral view; (C) palp, ventral view.

MALE. *Carapace* (Fig. 30A): fawnish red with top of head distinctly black, a brown submarginal band on the sides of the thorax; cuticle almost smooth (? pubescence lacking) with white wedge-shaped bands in constriction. *Chelicerae* (Fig. 30A): brownish orange with apex clear fawn; fangs olivaceous, fawnish clear at tip. *Abdomen*: dorsally with a grey stripe in its anterior third, the remainder deeper mouse grey; venter testaceous; spinnerets testaceous. *Legs*: pale yellow, the tarsus grey, a grey streak on the sides of some segments, notably the patellae, tibiae and metatarsi I (there also being grey below); femora and trochanters IV on anterior surface only; apices of patellae IV and base of tibiae IV grey. Ventral spination of tibiae I: 2-2-2. *Palp* (Fig. 30B, C): tibial apophysis long, distally hooked; flange well developed; proximal depression fringed with stout setae.

*Dimensions*: total length 8.7 mm, carapace length 2.6 mm. Ratio d: > 1.0.

BIOLOGY. Unknown.

DISTRIBUTION. Senegal.

MATERIAL EXAMINED. Left palp of holotype (the rest of the specimen is presumed lost), data given in synonymy.

### *Myrmarachne ichneumon* (Simon)

(Figs 31A-G; 32A-I)

*Salticus ichneumon* Simon, 1886: 387, ♂. LECTOTYPE ♂ (here designated), Tanzania (Zanzibar) (MNHN, Paris) [Examined]. Peckham & Peckham, 1892: 17, pl. 1, figs 7, 7a, 7b.

*Myrmarachne ichneumon* (Simon): Simon, 1901: 498. Peckham & Peckham, 1903: 250. Roewer, 1954: 943. Bonnet, 1957: 3007. Roewer, 1965: 47, figs 38, 38a. Prószyński, 1971b: 438.



**DIAGNOSIS.** *M. ichneumon* is a fairly distinctive species characterized by its orange colour and elongate body form. It is closely related to *M. elongata* Szombathy and *M. lulengensis* Roewer but can be separated by colour and also the ventral abdominal scutum in larger males. The genitalia are rather similar but the epigyne (Fig. 31D) of *ichneumon* is usually distinct with approximate lateral pouches.

*M. ichneumon* closely resembles *M. foreli* Lessert in body form and colour but can be readily distinguished by the presence of a distal hook on the tibial apophysis (Fig. 32B–D). *M. foreli* lacks a distal hook and is a member of the *formicaria*-group.

**MALE.** *Carapace* (Fig. 31A, B, G): finely punctured-reticulate; orange with yellowish guanin in eye region and white wedge-shaped band in constriction. *Eyes*: anteriors subcontiguous with apices procurved, fringed with fine white hairs. *Clypeus*: white haired. *Chelicerae* (Fig. 32E–G, I): rugulose with furrows; orange with orange-brown lateral keels; fang apophysis present. *Maxillae and Labium*: light orange, labium sometimes darker. *Sternum* (Fig. 32I): orange with darker margins. *Abdomen* (Fig. 31A, B, G): yellowish tinged with grey; dorsal scuta contiguous, orange but sometimes with darker markings; ventral scutum orange, apparently lacking in small specimens; very sparsely clothed with light orange hairs with very scanty white-haired bands in

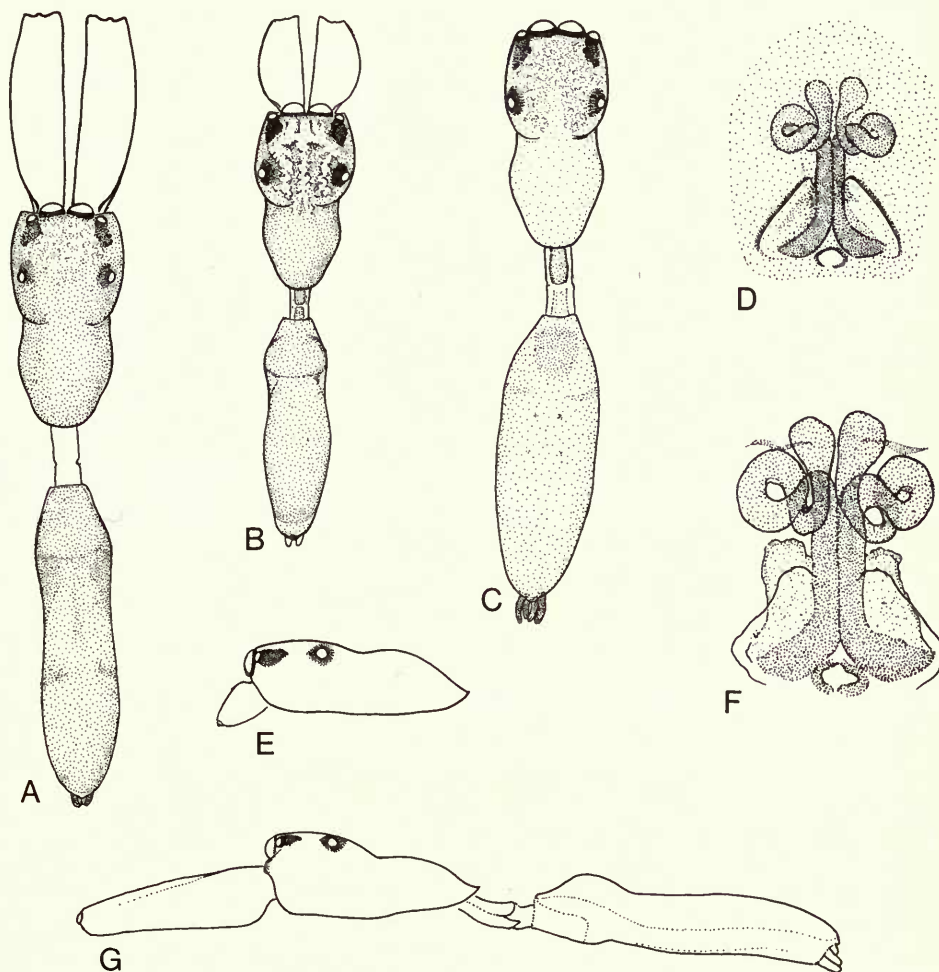

**Fig. 31** *Myrmarachne ichneumon* (Simon). Lectotype ♂: (A) dorsal view; (G) lateral view. ♂ from Kenya: (B) dorsal view. ♀ from Kenya: (C) dorsal view; (D) epigyne, ventral view; (E) carapace lateral view; (F) vulva, ventral view.



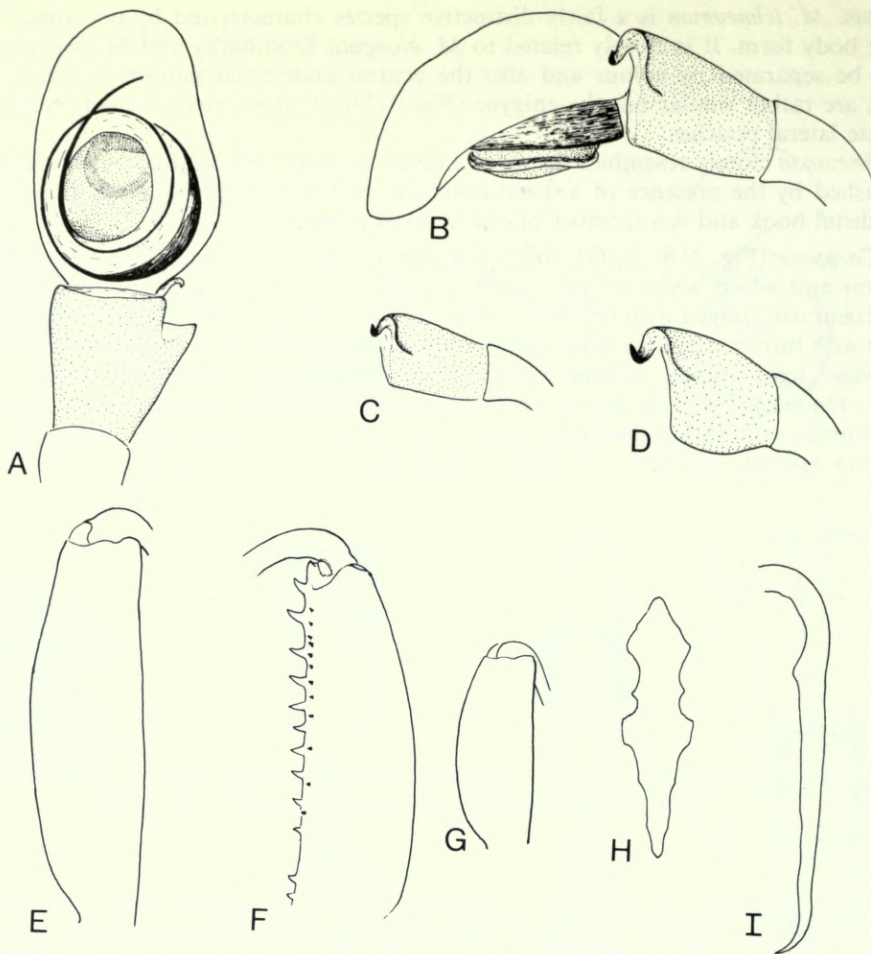

Fig. 32 *Myrmarachne ichneumon* (Simon). Lectotype ♂: (A) palp, ventral view; (B) palp, lateral view; (E) chelicera, dorsal view; (F) chelicera, ventral view; (H) sternum; (I) fang. ♂ from Kenya: (C) palpal tibia. ♂ from Durban: (D) palpal tibia. ♂ from Port Natal: (G) chelicera, dorsal view.

constriction; spinnerets dark orange-brown, sometimes blackish. *Legs*: slender, yellowish orange to orange with tarsi I brown-black and with black streaks on inside of tibiae I and patellae I. Ventral spination of legs I: metatarsi 2-2, tibiae usually 2-2-2, patellae 0. Femora with one or two dorsal or dorsolateral spines, lacking in small specimens. *Palp* (Fig. 32A-D): tibiae variable in shape; tibial apophysis distally hooked; flange moderately well developed; proximal depression fringed with slender setae.

*Dimensions*: total length 4.8-7.96 mm, carapace length 2.04-2.96 mm. *Ratios*: AM : AL : PM : PL: 10 : 5 : 1 : 5, AL-PM-PL: 6-10; a: 0.80-0.92, b: 0.88-1.0, c: 0.34-0.38, d: 0.52-0.79, e: 0.65-0.68 (7 ♂ examined).

**FEMALE.** *Carapace* (Fig. 31C, E): as in ♂. *Eyes*: more or less as in ♂. *Clypeus*: grey haired. *Chelicerae*: rugulose, light orange, shiny; promargin with 7 teeth, retromargin with 8. *Maxillae and Labium*: as in ♂. *Sternum*: yellow-orange. *Abdomen* (Fig. 31C): pale yellowish with a brownish orange patch anteriorly, an obscure brownish band in constriction with an incomplete blackish ring around the spinnerets; sparsely clothed with fine greyish hairs. *Legs*: more or less as in ♂ but tibiae and patellae I-II with black streaks inside. Ventral spination of legs I as in ♂ but

tibiae with 2-1 spines. *Epigyne* (Fig. 31D, F): usually distinct; lateral pouches approximate; spermathecae simple, basic figure eight configuration.

*Dimensions*: total length 6.52-7.98 mm, carapace length 2.52-2.86 mm. *Ratios*: AM : AL : PM : PL : 8 : 3.5 : 1 : 4, AL-PM-PL: 6-8.5; a: 1.0-1.02, b: 1.0-1.02, c: 0.34-0.35, e: 0.62-0.66 (6♀ examined).

Differences between individual males of this species are analogous with the variation found in male *M. elongata*. A small male from Kenya (accompanied by a female) has the carapace and chelicerae differently shaped (Fig. 31B) and appears to lack the ventral abdominal scutum. The tibiae of the palps are similar but clearly smaller than those of the holotype (Fig. 32C). A Durban specimen, the same size as the holotype, has the palpal tibiae differently shaped (Fig. 32D) with the dorsal and ventral surfaces more curved.

**BIOLOGY.** Unknown.

**DISTRIBUTION.** Kenya, South Africa, Tanzania.

**MATERIAL EXAMINED.** Lectotype ♂, data given in synonymy. **KENYA**: Kilifi, swept from low bushes and shrubs in a hot, dry sandy garden, 1♂, 1♀, 11.viii.1974 (*J. & F. Murphy*, vial 4049) (BMNH).

**SOUTH AFRICA**: Port Natal, 1♂, 2♀; Durban, 1♂ (*G. P. Staunton*); Durban, 1♂ (*J. F. Quekett*)

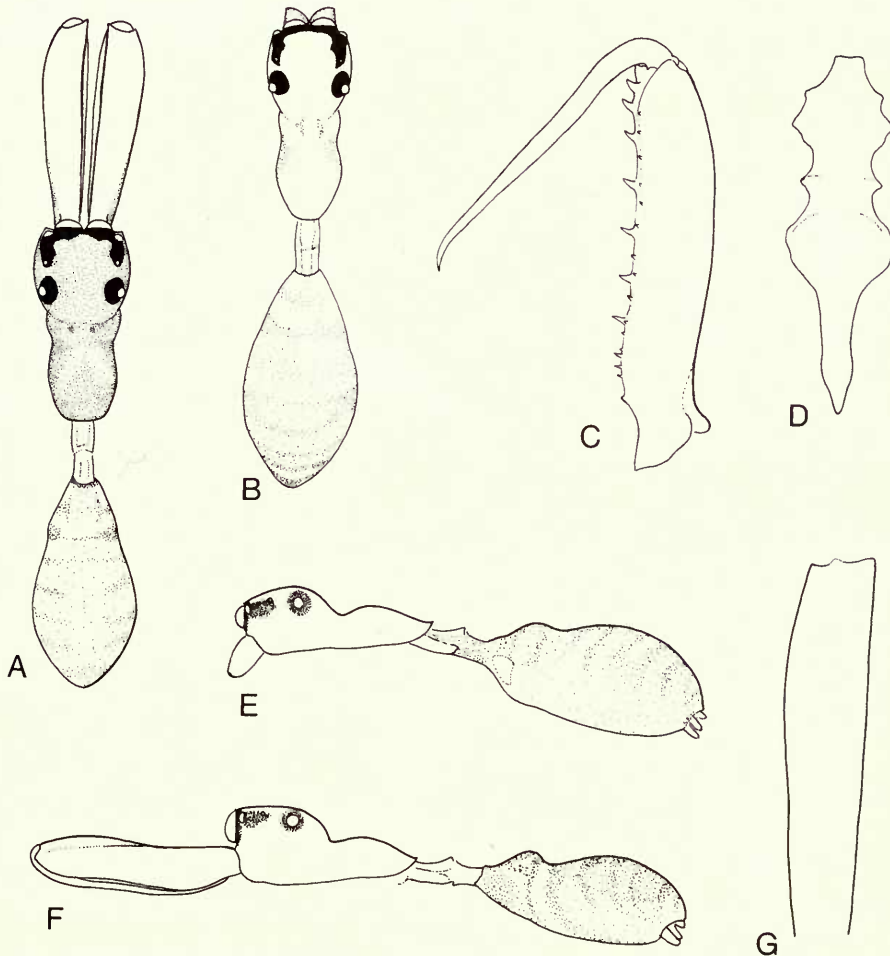

**Fig. 33** *Myrmarachne foenisex* Simon. ♂: (A) dorsal view; (C) chelicera, ventral view; (D) sternum; (F) lateral view; (G) chelicera dorsal view. ♀: (B) dorsal view; (E) lateral view.



(BMNH), Umkomaas, 1 ♀, 30.iv.1965 (A. L. Capener, NM 9493); Scottsville, Pietermaritzburg, 1 ♀, xi.1947 (R. F. Lawrence, NM 5255) (NM, Pietermaritzburg). TANZANIA: Mts Uluguru, Kiroka forest, 1 ♂, 27–31.v.1971 (L. Berger, N. Leleup, J. Debecker, MT 141075) (MRAC, Tervuren).

*Myrmarachne foenisex* Simon

(Figs 33A–G; 34A–E; Pls 1h; 2a; 3e, f)

*Myrmarachne foenisex* Simon, 1910 : 415, ♂. LECTOTYPE ♂ (here designated), Gabon, Fernand Vaz (MNHN, Paris) [Examined]. Giltay, 1929 : 25, figs 3, 4. Collart, 1929a : 147; 1929b : 117; 1941 : 1. Berland & Millot, 1941 : 406, fig. 96a, b, c. Lessert, 1942 : 10, fig. 5. Roewer, 1954 : 942. Bonnet, 1957 : 3002. Roewer, 1965 : 39, figs 28a, b, c, 43. Prószyński, 1971b : 437.

DIAGNOSIS. *M. foenisex* is a distinctive species readily separated from other members of the *tristis*-group by its characteristic body form and colour (Fig. 33A, B). Its affinities are uncertain but it is fairly close to *M. richardsi* sp. n.

MALE. *Carapace* (Fig. 33A–F; Pls 1h; 2a; 3e, f): generally punctured-reticulate; light orange, orange-brown or dark brownish with darker markings in constriction; sparsely clothed with fine, light orange hairs in eye region and posterior part of thorax with white hairs elsewhere, sometimes forming scanty, transverse bands on the thorax. *Eye*: anteriors subcontiguous with apices pro-curved, fringed with whitish hairs. *Clypeus*: fringed with long whitish hairs. *Chelicerae* (Fig.

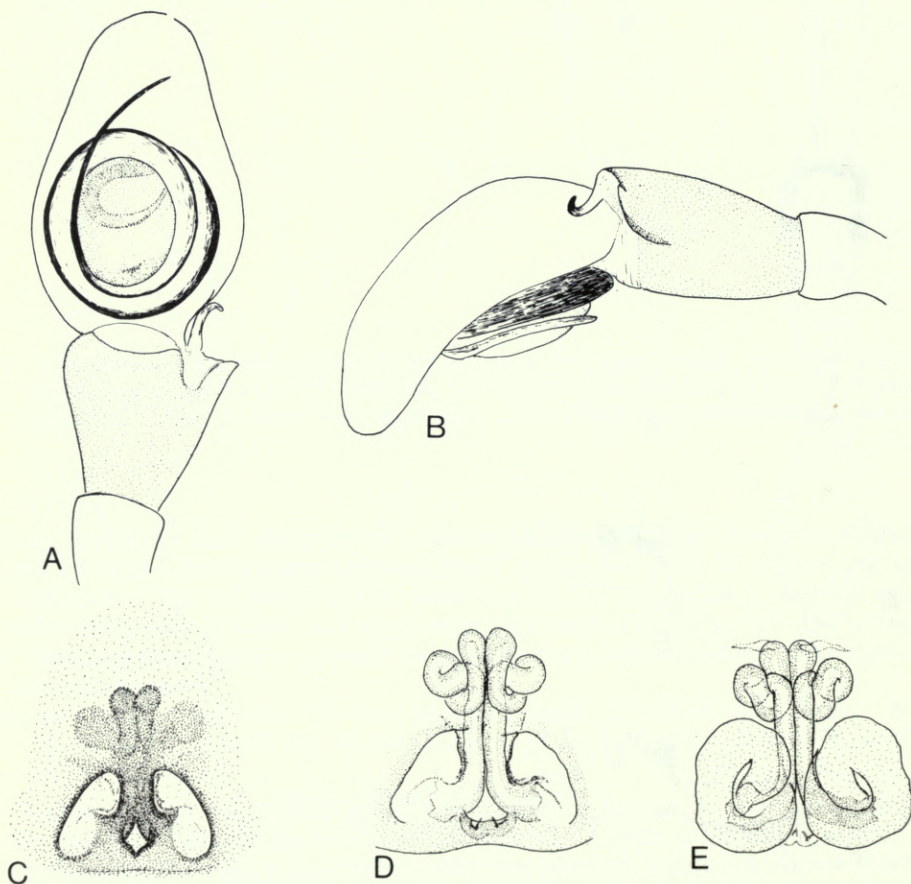

Fig. 34 *Myrmarachne foenisex* Simon. ♂: (A) palp, ventral view; (B) palp, lateral view. ♀: (C) epigyne, ventral view; (D) vulva ventral view; (E) vulva, dorsal view.



33C, G): rugulose, furrows scarcely evident; orange with blackish lateral keels; fang apophysis normally lacking but present in some Angola specimens (Ang. 11238.1, 22090). *Maxillae and Labium*: light orange. *Sternum* (Fig. 33D): light orange with darker margins. *Abdomen* (Fig. 33A, F): yellowish with faint blackish mottling; dorsal scuta orange or orange-brown, sometimes with a series of faint blackish bands; ventral scutum weak, light orange; clothed with fine, light orange-brown hairs. *Legs*: slender, legs I tarsi yellow-brown; metatarsi orange-brown; tibiae and patellae yellow-brown with blackish streaks externally; other segments yellow-brown with blackish sides. Legs II as I but metatarsi, trochanters and coxae yellow-brown. Legs III brownish orange to light orange-brown distally. Legs IV as III but trochanters and coxae light yellowish. Ventral spination of legs I: metatarsi 2-2-2, tibiae usually 2-2-2-2, patellae 0. *Palp* (Fig. 34A, B): tibial apophysis distally hooked; flange well developed; proximal depression fringed with stout, black setae.

*Dimensions*: total length 5.2-7.5 mm, carapace length 2.28-3.24 mm. *Ratios*: AM : AL : PM : PL : 11 : 5 : 1.5 : 6, AL-PM-PL: 8-10; a: 0.94-1.02, b: 1.0-1.02, c: 0.36-0.39; d: 0.47-1.06 e: 1.03-1.05 (10♂ examined).

FEMALE. *Carapace* (Fig. 33B, E): as in ♂. *Eyes*: more or less as in ♂. *Chelicerae*: rugulose; yellowish orange, shiny; promargin with 7 or 8 teeth, retromargin with 10 or 11. *Maxillae and Labium*: as in ♂. *Sternum*: as in ♂. *Abdomen* (Fig. 33B, E): as in ♂ but scuta lacking. *Legs*: more or less as in ♂. Ventral spination as in ♂. *Epigyne* (Fig. 34C-E): sometimes indistinct; lateral pouches apparently contiguous; spermathecae simple, basic figure of eight configuration.

*Dimensions*: total length 5.68-7.92 mm, carapace length 2.52-3.12 mm. *Ratios*: AM : AL : PM : PL : 10.5 : 5 : 1 : 6, AL-PM-PL: 7-9; a: 1.02-1.04, b: 1.02-1.04, c: 0.35-0.38, e: 0.98-1.01 (7♀ examined).

BIOLOGY. Some aspects have been described by Collart (1929a, 1929b, 1941). *M. foenisex* mimics the weaver ant *Oecophylla longinoda* (Latreille) in colour, form and behaviour. It is always found in close proximity to the ant nests which are arboreal and consist of several leaves bound together by silk emitted from the ant larva (Pl. 6a, b). The spider avoids direct contact with the ants, but nevertheless often occurs in the nest. It will feed on small insects and will apparently milk coccids. There is no courtship and at the time of egg laying females are gregarious. They normally lay about 25 eggs in two batches so that eggs and developing embryos may be found in the same nest.

Mr B. Bolton (pers. comm.) has examined the contents of many *longinoda* nests in Western Nigeria and has found *foenisex* actually inside the stitched leaves of cocoa trees (see also Material examined). In some nests the spiders were seen with an ant larva in their jaws. From these observations it would seem reasonable to assume that *foenisex* feeds on ant larvae but as Bolton pointed out it is also possible that the spiders were mimicking ant behaviour as they too take hold of larvae when the nest is disturbed (Pl. 7).

DISTRIBUTION. Angola, Gabon, Ghana, Guinea, Nigeria, Senegal, Zaire.

MATERIAL EXAMINED. Lectotype ♂, data given in synonymy. ANGOLA: Dundo, with egg-sac, within dried sheet of *Chaetocarpus africanus*, 1♀, 3.ii.1949 (A. B. Machado, Ang. 1317.1); 1♂, 1956 (A. B. Machado, Ang. 11238.1); inside nest of *O. longinoda*, with egg-sac, 1♀, 26.v.1962 (E. Carvalho, Ang. 1703.4); 1♂, 6.xi.1969 (E. Carvalho, Ang. 22090) (BMNH). GHANA: Legon, from inside *O. longinoda* nests, 27.iv.1976 (J. Lee), 2♂, 1♀, 1 immature nest ON 70, 2♀ nest ON 71, 1♀ nest ON 73; Legon, 1♂, xi.1969 (*M. Edmunds*); Legon, 1♀, iii.1969 (*M. Edmunds*); Legon, 3♂, 2♀, xii-i.1973/74 (*M. Edmunds*, vial 39); Mt Atewa, 2♂, 1.viii.1973 (*M. Edmunds*, vial 9); Kade, 1♂, 1♀, 1.ix.1971 (J. D. Majer) (BMNH). GUINEA: Kindia, 1♀, 1937 (L. Berland & J. Millot) (MNHN, Paris). NIGERIA: 1♂, 16.xii.1941 (F. D. Golding) (BMNH). SENEGAL: Dakar, 1♂, ix.1937 (L. Berland & J. Millot) (MNHN, Paris). ZAIRE: Tkenge, 1♀, 17.ix.1912 (R. Mayne, MT 70869); Makala Ntete, 1♂, 23.iii.1922 (H. Schouteden, MT 130758.1) (MRAC, Tervuren).

### *Myrmarachne richardsi* sp. n.

(Fig. 35A-H)

DIAGNOSIS. *M. richardsi* is a fairly distinctive species distinguished from other members of the

*tristis*-group by the shape of the carapace (Fig. 35A, G). It is closely related to *M. foenisex* Simon but can be readily separated by its brown-black colour. *M. richardsi* is very similar in body form to *M. vanessae* sp. n. but can be distinguished by its colour and presence of the hooked tibial apophysis (Fig. 35F).

FEMALE. Unknown.

MALE. *Carapace* (Fig. 35A, G): punctured-reticulate; brown-black with lower part of constriction orange-brown; sparsely clothed with whitish hairs in eye region. *Eyes*: anteriors subcontiguous with apices procurved, fringed with whitish hairs. *Clypeus*: white haired. *Chelicerae* (Fig. 35C-E): rugulose with furrows; orange-brown, shiny, with blackish lateral keels; fang apophysis present. *Maxillae and Labium*: brown-black with inner margins of maxillae and labial tip yellow-brown. *Sternum* (Fig. 35H): brownish. *Abdomen* (Fig. 35A, G): mottled brownish black with glossy, brown scuta; very sparsely clothed with light brownish hairs. *Legs*: slender, legs I tarsi yellow-brown; metatarsi brownish black; tibiae, patellae and femora yellow-brown with blackish sides; trochanters and coxae brownish black. Legs II as I but metatarsi yellow-brown. Legs III as II but femora brownish black. Legs IV brownish black but tarsi yellowish,

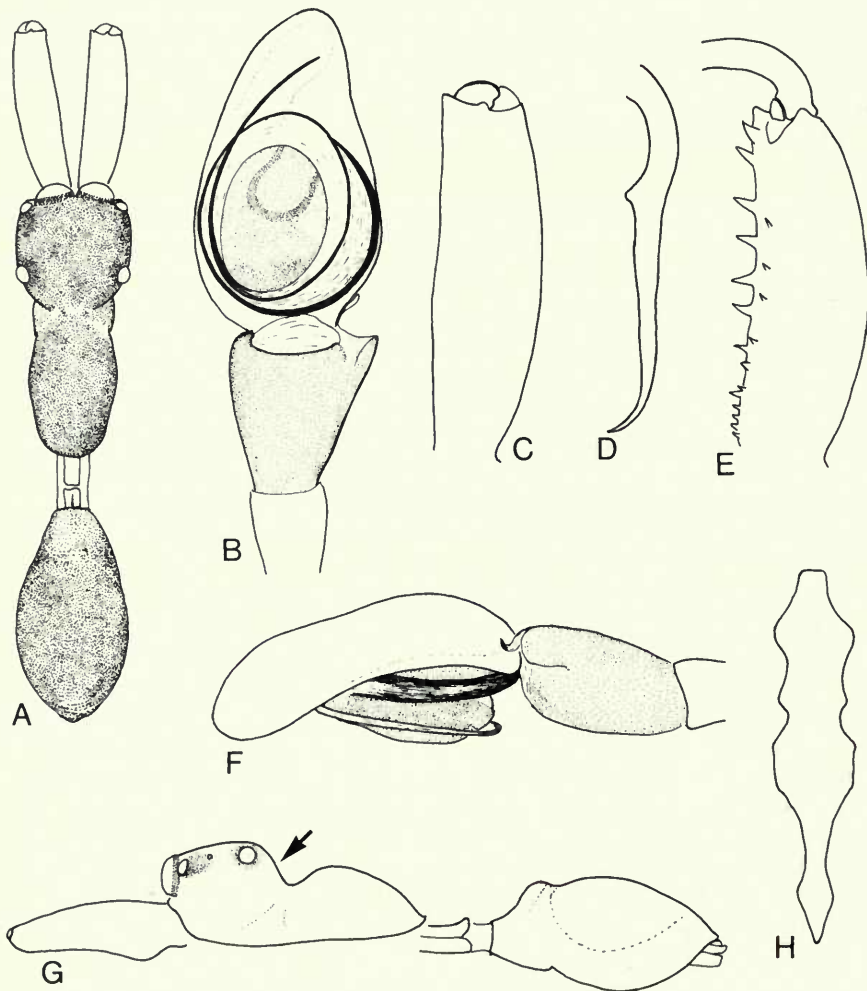

Fig. 35 *Myrmarachne richardsi* sp. n. Holotype ♂: (A) dorsal view; (B) palp, ventral view; (C) chelicera, dorsal view; (D) fang; (E) chelicera ventral view; (F) palp, lateral view; (G) lateral view; (H) sternum.

with yellowish marks on trochanters and patellae. Ventral spination of legs I: metatarsi 2-2, tibiae 2-2-2-2, patellae 0. *Palp* (Fig. 35B, F): tibial apophysis hooked; flange relatively small; proximal depression extends to mid-length, fringed with slender setae.

*Dimensions*: total length 4.6 mm, carapace length 2.4 mm. *Ratios*: AM : AL : PM : PL : 8.5 : 4.5 : 1 : 4.5, AL-PM-PL: 4.5-6; a: 1.02, b: 1.02, c: 0.33, d: 0.58, e: 0.93 (1 ♂ examined).

**BIOLOGY.** Unknown.

**DISTRIBUTION.** Ghana.

**MATERIAL EXAMINED.** Holotype ♂, GHANA: Legon, in wasp cell, No. 81, *Pison* species; 14.iii.69 (O. W. Richards) (BMNH, reg. no. 1977.4.21.33).

**ETYMOLOGY.** The species is named after the wasp specialist and collector Professor O. W. Richards.

***Myrmarachne tristis* (Simon)**

(Figs 36A-H; 37A-E)

*Salticus tristis* Simon, 1882 : 212, ♀. **LECTOTYPE** ♀ (here designated), Yemen (MCSN, Genoa) [Examined]. Simon, 1890 : 115. Peckham & Peckham, 1892 : 22, pl. III, figs 2, 2a, 2b.

*Salticus tristis* var. *rufula* Peckham & Peckham, 1892 : 22, pl. III, figs 2c, 2d, ♂. **LECTOTYPE** ♂ (here designated), Aden (MCZ, Harvard) [Examined]. Denis, 1966 : 113.

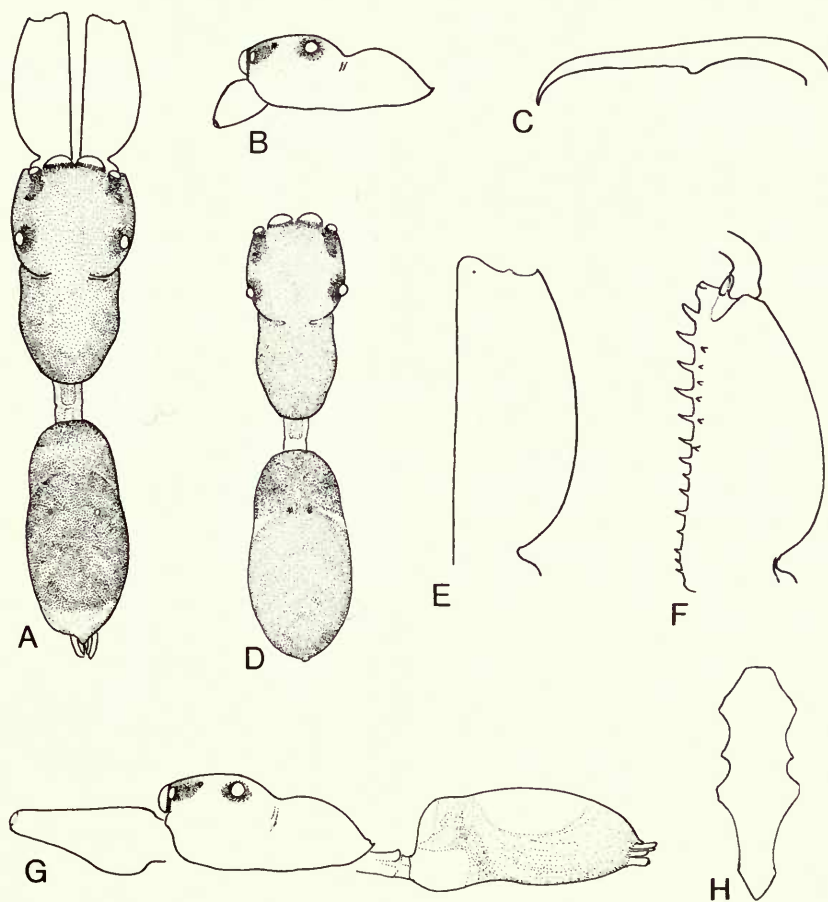

**Fig. 36** *Myrmarachne tristis* (Simon). ♂ from Yemen: (A) dorsal view; (C) fang; (E) chelicera, dorsal view; (F) chelicera, ventral view; (G) lateral view; (H) sternum. ♀: (B) carapace, lateral view; (D) dorsal view.



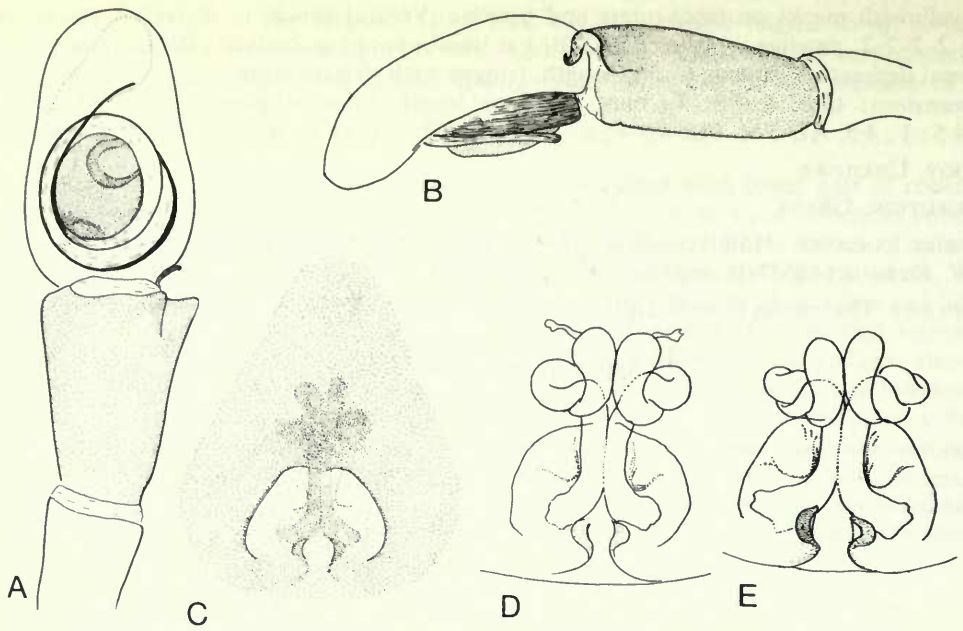

**Fig. 37** *Myrmarachne tristis* (Simon). ♂ from Yemen: (A) palp, ventral view; (B) palp, lateral view. ♀ from Yemen: (D) vulva, ventral view; (E) vulva, ventral view of another specimen showing more complex spermathecae.

*Myrmarachne tristis* (Simon): Simon, 1901 : 501, 503. Narayan, 1915 : 397, pl. XXXII, fig. 3. Caporiacco, 1933 : 333. Roewer, 1954 : 944. Bonnet, 1957 : 3014. Roewer, 1965 : 42, figs 35, 35a. Denis, 1966 : 112, fig. 13. Prószyński, 1971b : 440.

*Myrmarachne tristis* var. *diversipes* Denis, 1966 : 113, ♂. Libya, environs of lake Tadem'ka (MNHN, Paris) [Not examined, presumed lost].

**DIAGNOSIS.** *M. tristis* closely resembles *M. marshalli* Peckham & Peckham and *M. legon* sp. n. but may be separated by the presence of only two trichobothria in the mid-dorsal region of the postocular constriction; males may also be distinguished by the well-developed flange (Fig. 37B) and relatively broad chelicerae (Fig. 36A, E), and females sometimes with difficulty by the more or less distinct epigyne (Fig. 37C) and relatively large lateral pouches.

**MALE.** *Carapace* (Fig. 36A, G): punctured-reticulate; light orange-brown or dark orange-brown with fine, scattered white hairs, and white wedge-shaped bands in constriction. *Eyes*: anteriors subcontiguous with apices procurved, fringed with whitish hairs. *Clypeus*: white haired, *Chelicerae* (Fig. 36C, E, F): rugulose with furrows; orange-brown with blackish lateral keels; fang apophysis present. *Maxillae and Labium*: orange-brown but inner margins of maxillae and labial tip lighter. *Sternum* (Fig. 36H): orange or orange-brown, margins sometimes darker. *Abdomen* (Fig. 36A, G): mottled yellow-brown and black; scuta orange-brown; clothed with yellowish hairs with whitish ones in constriction. *Legs*: slender; legs I orange-brown but tibiae and patellae a shade lighter with blackish streaks inside. Legs II similar to I but with blackish streaks along inside of femora. Legs III orange-brown but tarsi and metatarsi lighter. Legs IV as III but patellae and trocha trochanters marked with yellowish. Ventral spination of legs I: metatarsi 2-2, tibiae rather variable, between 2-2-2 and 2-1, patellae 0. *Palp* (Fig. 37A, B): tibial apophysis distally hooked; flange well developed; proximal depression fringed with slender setae.

*Dimensions*: total length 4.04-6.44 mm, carapace length 1.92-3.04 mm. *Ratios*: AM : AL : PM : PL: 10 : 5 : 1.2 : 6, AL-PM-PL: 7-10; a: 0.83-0.96, b: 0.91-1.01, c: 0.38-0.42, d: 0.52-0.65, e: 0.74-0.95 (10 ♂ examined).

FEMALE. *Carapace* (Fig. 36B, D): more or less as in ♂. *Eyes*: as in ♂. *Clypeus*: fringed with light brown hairs. *Chelicerae*: rugulose; orange; promargin with 6–8 teeth, retromargin with 4 or 5. *Maxillae and Labium*: as in ♂. *Sternum*: as in ♂. *Abdomen* (Fig. 36B–D): light orange-brown with blackish mottling; clothed with light yellowish hairs with whitish ones in constriction. *Legs*: slender, legs I tarsi and metatarsi orange-brown; tibiae and patellae yellow-brown with blackish streaks along the sides; femora orange-brown with distal sides yellowish; trochanters and coxae yellowish. Legs II yellow-brown with blackish lateral streaks on tibiae, patellae and femora and on outside of trochanters and coxae. Legs III orange-brown grading to yellow-brown on metatarsi and tarsi. Legs IV orange-brown but trochanters and patellae marked with yellowish. Ventral spination of legs I more or less as in ♂. *Epigyne* (Fig. 37C–E): usually distinct with fairly large lateral lobes that sometimes have distinctly curved lower margins; spermathecae rather variable, configuration simple or relatively complex.

*Dimensions*: total length 4.8–5.7 mm, carapace 2.0–2.5 mm. *Ratios*: AM : AL : PM : PL : 9 : 5 : 1.2 : 5.5, AL–PM–PL: 7–8.5; a: 1.02, b: 1.02, c: 0.38–0.40, e: 0.68–0.83 (10 ♀ examined).

**BIOLOGY.** Unknown but Simon (1890) states that in Yemen, *M. tristis* is extremely common, principally on *Acacia*.

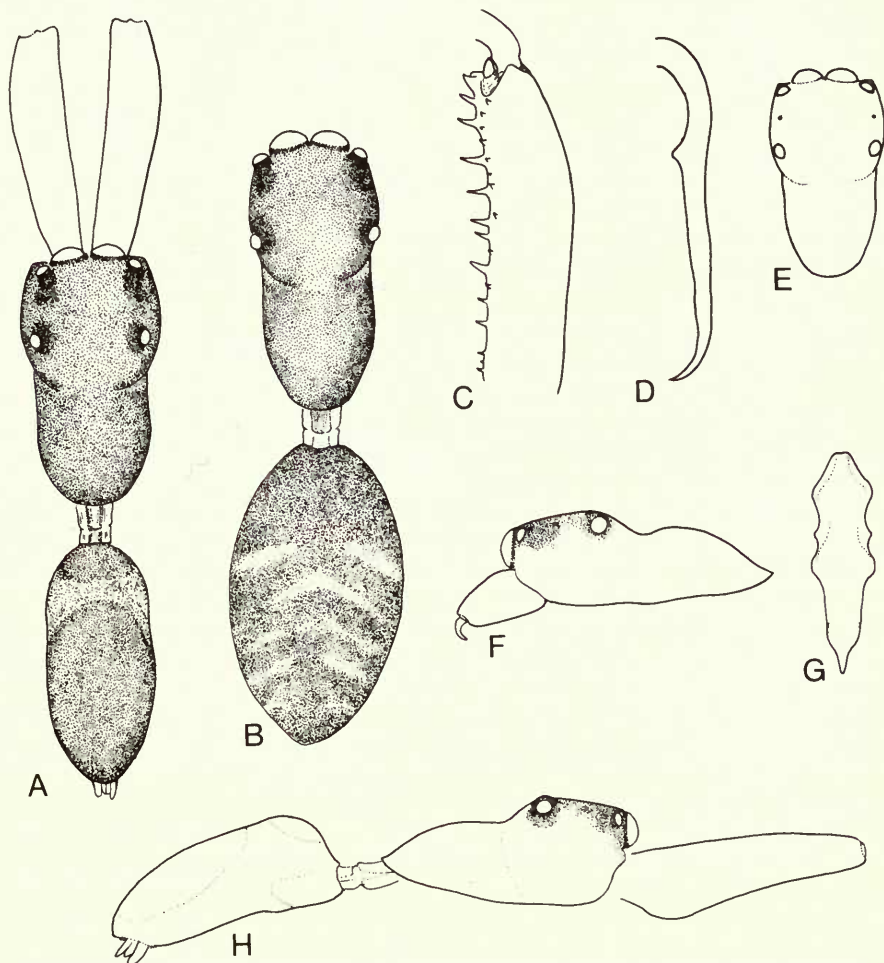

**Fig. 38** *Myrmarachne marshalli* Peckham & Peckham. Lectotype ♂: (A) dorsal view; (C) chelicera, ventral view; (D) fang; (H) lateral view. Paralectotype ♀: (B) dorsal view; (F) lateral view; (G) sternum. Lectotype ♂ of *M. akermani* Lawrence: (E) carapace, dorsal view.

DISTRIBUTION. Egypt, Libya, Soudan, Yemen.

MATERIAL EXAMINED. Type data given in synonymy. EGYPT: 1 ♂, 1901 (*L. A. Jägerskiöld*) (MNHN, Paris). LIBYA: Environs of Lake Tadem'ka, 1 ♂, 28.iii.1944 (MNHN, Paris). SOUDAN: Khartoum, 1 ♀, 1962/63 (*J. L. Cloudsley-Thompson*, MT 123050) (MRAC, Tervuren). YEMEN: 13 ♂, 30 ♀ (*E. Simon*), 3 ♂, 12 ♀ (*E. Simon*) (MNHN, Paris); 1 ♂, 2 ♀ (*E. Simon*) (MCZ, Harvard).

REMARKS. The Indian records given by Narayan (1915) are possibly in error as there exists in India, Sri Lanka and Iran a species of *Myrmarachne* very close to *M. tristis* in body form but differing in genital structure.

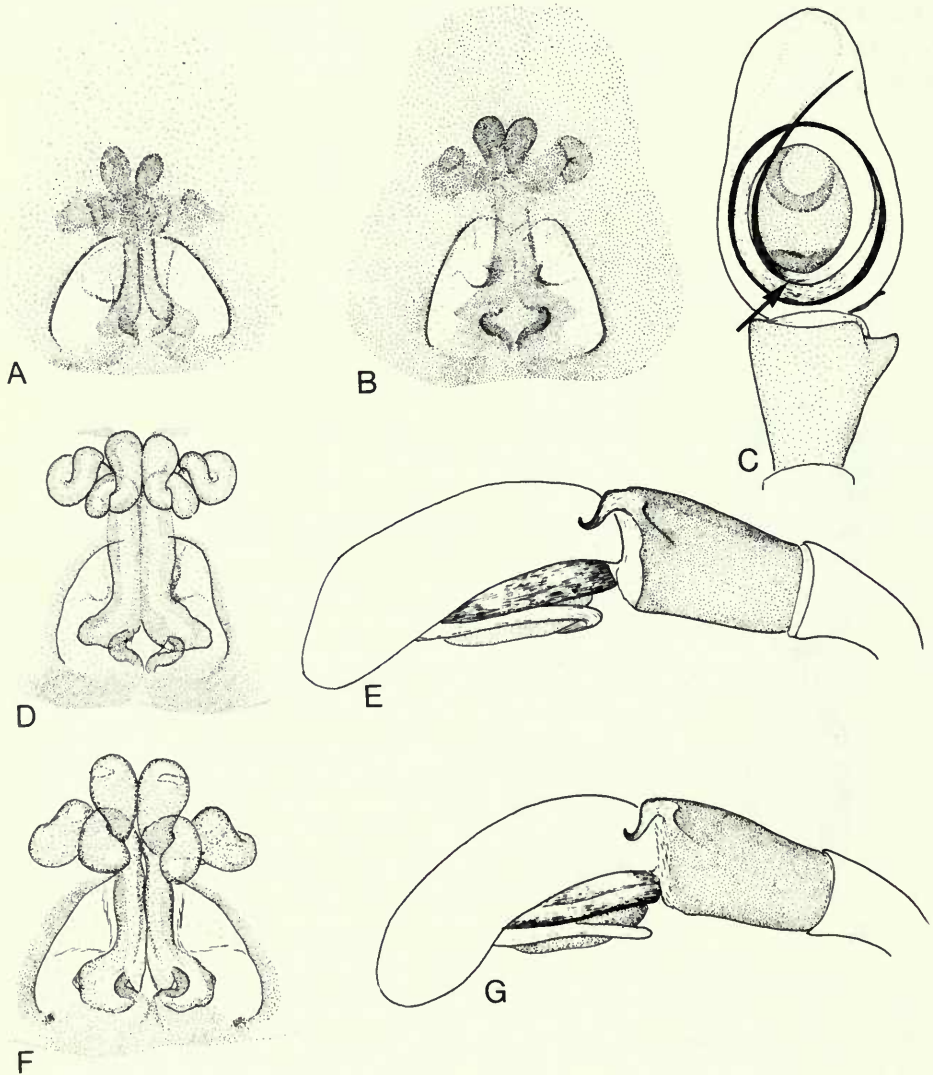

Fig. 39 *Myrmarachne marshalli* Peckham & Peckham. Paralectotype ♀: (A) epigyne, ventral view; (F) vulva, ventral view. Paralectotype ♀ of *M. akermani* Lawrence: (B) epigyne, ventral view; (D) vulva, ventral view. Lectotype ♂: (C) palp, ventral view; (G) palp, lateral view. ♂ holotype of *M. riveti* Berland & Millot, (E) palp, lateral view.



*Myrmarachne marshalli* Peckham & Peckham

(Figs 38A–H; 39A–G; 40A–K; Pl. 4a, c, e)

*Myrmarachne marshalli* Peckham & Peckham, 1903 : 249, pl. 24, figs 6, 6a, 6b, ♂, ♀. LECTOTYPE ♂ (here designated), South Africa, Mashonaland (MCZ, Harvard) [Examined]. Lawrence, 1941 : 184. Roewer, 1954 : 943. Bonnet, 1957 : 3009. Roewer, 1965 : 62, fig. 68. Prószyński, 1971b : 439.

*Myrmarachne riveti* Berland & Millot, 1941 : 410, fig. 99, ♂. Holotype ♂, Guinea, Kinda (MNHN, Paris) [Examined]. Roewer, 1954 : 943; 1965 : 71, fig. 69. **Syn. n.**

*Myrmarachne akermani* Lawrence, 1941 : 181, figs 28, 29, ♂, ♀. LECTOTYPE ♂ (here designated), South Africa, Winklespruit, Natal (NM, Pietermaritzburg) [Examined]. Roewer, 1954 : 941; 1965 : 68. Prószyński, 1971b : 68. **Syn. n.**

*Myrmarachne burgeoni* Roewer, 1965 : 54, figs 56, 56a, ♂, ♀. Holotype ♂, Zaire, Ngoma (MRAC, Tervuren) [Examined]. Prószyński, 1971b : 437. **Syn. n.**

*Myrmarachne bredoi* Roewer, 1965 : 55, fig. 57, ♂. Holotype ♂, Zaire, Kasenyi (MRAC, Tervuren) [Examined]. Prószyński, 1971b : 437. **Syn. n.**

*Myrmarachne benoiti* Roewer, 1965 : 57, fig. 60, ♂. Holotype ♂, Zaire, Isle Idjwi (Lake Kivu) (MRAC, Tervuren) [Examined]. Prószyński, 1971b : 436. **Syn. n.**

*Myrmarachne mulungu* Roewer, 1965 : 59, fig. 63, ♂. Holotype ♂, Zaire, Mulungu (MRAC, Tervuren) [Examined]. Prószyński, 1971b : 439. **Syn. n.**

Vial MT 11775 labelled *Myrmarachne burgeoni*, holotype ♂, allotype ♀, contains 2♂ and 1♀. One of the males agrees more or less with the description of Roewer (1965) and is presumed to be the holotype. The other male, and the female, appear to be conspecific with *M. lawrencei* Roewer.

**DIAGNOSIS.** *M. marshalli* is a very variable species closely related to *M. legon* sp. n. and *M. tristis* (Simon) but may be distinguished by the four trichobothria in the mid-dorsal region of the postocular constriction, and the longitudinal fringe of white hairs on the thorax (Pl. 4a). Rubbed specimens are separated by the relatively narrow chelicerae (Fig. 40A–K), poorly developed flange and relatively large tegulum (Fig. 39C, E, G). Females are separated with difficulty by the structure of the poorly defined epigyne (Fig. 39A, B, D, F).

**MALE.** *Carapace* (Fig. 38A, E, H; Pl. 4a, c, e): punctured-reticulate with papillae on thoracic part; reddish brown or brown-black with scattered white hairs forming an ill-defined, longitudinal fringe on thoracic part, and white wedged-shaped bands in constriction. *Eyes*: anterior subcontiguous with apices procurved; fringed with white hairs. *Clypeus*: white haired. *Chelicerae* (Fig. 40A–K): rugulose with furrows; orange or yellow-orange, sometimes reddish, with blackish lateral keels; sparsely clothed with long whitish hairs proximally; tibial apophysis present. *Maxillae and Labium*: orange-brown with inner margins of maxillae and labial tip lighter. *Sternum*: elongate, orange-brown with darker margins. *Abdomen* (Fig. 38A, H): mottled brownish black with dark orange-brown scuta; clothed with whitish hairs. *Legs*: legs I tarsi brown; metatarsi yellow-brown; tibiae and patellae yellow-brown with blackish lateral streaks; femora orange-brown with darker sides; trochanters and coxae yellow-brown. Legs II yellow-brown with blackish lateral streaks on tibiae, patellae and femora. Legs III tarsi, metatarsi and tibiae yellow-brown the latter with darker sides; other segments orange-brown. Legs IV orange-brown but coxae, trochanters and patellae marked with yellowish. Ventral spination of legs I variable, metatarsi 2–2, tibiae usually 2–2–2–2, patellae 0. *Palp* (Fig. 39C, E, G): tibial apophysis distally hooked; flange poorly developed at least in lateral view; proximal depression fringed with stout setae.

*Dimensions*: total length 4.5–6.7 mm, carapace length 2.12–3.2 mm. *Ratios*: AM : AL : PM : PL : 11 : 5 : 1.5 : 6, AL–PM–PL : 7–8.5; a : 0.88–1.02, b : 0.88–1.0, c : 0.36–0.41, d : 0.64–1.02, e : 0.88–1.10 (10♂ examined).

**FEMALE.** *Carapace* (Fig. 38B, F): more or less as in ♂. *Eyes*: as in ♂. *Clypeus*: fringed with brownish hairs. *Chelicerae*: rugulose; orange-brown tinged with blackish, shiny; promargin with 6 or 7 teeth, retromargin with 7 or 8. *Maxillae and Labium*: as in ♂. *Sternum*: as in ♂. *Abdomen* (Fig. 38B): mottled yellow-brown and black with a golden sheen and a poorly defined series of chevrons composed of whitish hairs; sometimes a brownish patch anteriorly; in constriction a band of

whitish hairs extending and broadening posteriorly to sides of venter. *Legs*: legs I tarsi brownish; other segments yellow-brown to light yellowish with black streaks on both sides excepting coxae. Legs II tarsi, metatarsi and tibiae yellow-brown, the latter with proximal lateral stripes; other segments light yellow-brown but with a black spot on coxae and black streaks inside of femora and on both sides of patellae and trochanters. Legs III tarsi, metatarsi and tibiae yellow-brown the latter with proximal stripes externally; remaining segments dark orange-brown. Legs IV as III but metatarsi orange-brown; patellae marked with yellowish; trochanters and coxae light yellow with blackish sides. Ventral spination of legs I as in ♂. *Epigyne* (Fig. 39A, B, D, F): often poorly defined and rather variable in appearance; lateral pouches approximate; spermathecae relatively complex.

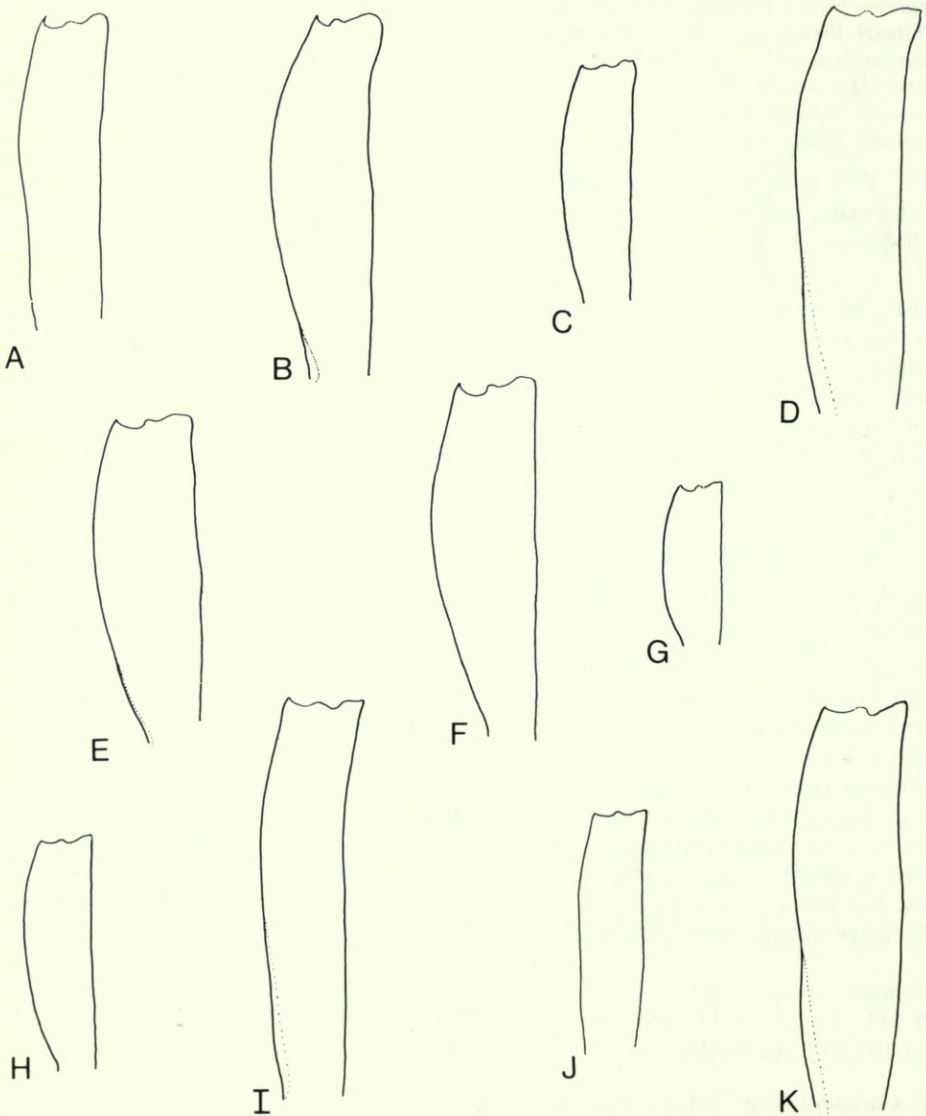

**Fig. 40** *Myrmarachne marshalli* Peckham & Peckham. ♂ chelicera showing variation in size and shape (drawn to scale): (A) lectotype of *M. marshalli* Peckham & Peckham; (B) holotype of *M. burgeoni* Roewer; (C) holotype of *M. mulungu* Roewer; (D, F, G, K) males from S. Africa; (E) holotype of *M. riveti* Berland & Millot; (H-J) males from Zaire.



*Dimensions*: total length 4.44–7.04 mm, carapace length 2.14–3.12 mm; *Ratios*: AM : AL : PM : PL : 9 : 4 : 1 : 5; AL–PM–PL: 6.5–7; a: 1.02–1.04, b: 1.02–1.04, c: 0.36–0.39, e: 0.92–1.01 (8 ♀ examined).

Male chelicerae (Fig. 40A–K) show allometric variation with a trend towards the development of a distal boss in larger specimens. Small males sometimes have the carapace more attenuate posteriorly with ratios a and b close to 1.0 (Fig. 38E). The palps vary slightly in the relative length of the tibiae (Fig. 39E, G) and in the angle subtended by the tibial apophysis also a minute ‘tooth’ at the point where the pars pendula joins the embolus is not always apparent and may be an artifact (location arrowed in Fig. 39C).

**BIOLOGY.** *M. marshalli* mimics at least 2 species of *Camponotus* ant and has been found in association with human habitations. It has also been collected from silken cells spun over the midrib of palm scrub in Botswana (A. Russell-Smith and F. Wanless, unpublished observations).

**DISTRIBUTION.** Angola, Botswana, Guinea, Kenya, Nigeria, South Africa, Tanzania, Zaire.

**MATERIAL EXAMINED.** Type data given in synonymy. ANGOLA: Lake Calundo, Hiemilignosa, in ant’s nest in *Cubitermes* termitarium, 1 ♂, 19.i.1955 (*Luna de Carvalho*, Ang. 4735.4); Cazombo river, Nhá-Bica, affl. Zambeze, with japanese umbrella, 1 ♀, 18.ii.1955 (*A. B. Machado*, Ang. 4977.4) (BMNH). BOTSWANA: Boro river, Dandridge House, nr Maun, on walls with *Camponotus* ants, 3 ♀, 29.ii.1976 (*A. Russell-Smith, F. Wanless*); Manxunyane lagoon, nr Maun: grassland, net sweeping, 1 ♂, 4.iii.1976, palm scrub, 3 ♀, 1.iv.1976 (*A. Russell-Smith, F. Wanless*) (BMNH). KENYA: Nairobi, Muthaiga golf course, from tree trunks, 1 ♂, 1 ♀, 15.vii.1974 (*J. & F. Murphy*, vial 3538); Kakamega forest, beaten from shrubs at the edge of a path through the rain forest, 1 ♂, 12.viii.1972 (*J. & F. Murphy*, vial 1898) (BMNH); Takaungu, 2 ♂ (*B. Percivil*) (BMNH). NIGERIA: Ibadan, 1 ♂, 28.iii.1973 (*A. Russell-Smith*) (BMNH). SOUTH AFRICA: Natal, Pietermaritzburg, with *Camponotus* ants: 1 ♂, viii.1910 (*C. Akerman*, NM. 1695); 1 ♀, x.1942 (*C. Akerman*, NM. 3817); 1 ♂, 2 ♀, xii.1943 (*R. A. Holliday*, NM. 4218, 4226, 4230); Pietermaritzburg, 1 ♂, ii.1933 (*O. Harwin*, NM. 1733); 1 ♂, ix.1942 (*R. A. Holliday*, NM. 3814); 1 ♀, xi.1961 (*M. Delvin*, NM. 8097); Natal, Winklespruit, 1 ♂ (*C. Akerman*, NM. 1735); Umhlali, North Coast, Natal, 1 ♂, 11.1940 (*R. F. Lawrence*, NM. 20138) (NM, Pietermaritzburg); Natal, 1 ♂ (*C. Martin*) (MNHN, Paris); 2 ♂, 2 ♀, Transvaal, Pretoria (MNHN, Paris). TANZANIA: Arusha, on walls, 2 ♂, 1 ♀, xiii.1968 (BMNH). ZAIRE: Uvira, in hymenopteran nest, 1 ♂, 7.ix.1959 (*G. Marlier*, MT 116276); Uvira, in house, 1 ♂, 2.xii.1954 (*G. Marlier*, MT 85440); Kinshasa, with *Camponotus* ants, 2 ♂, xi.1972 (*J. van Ryn-Tormel*, MT 146090); Kinshasa, Meyen Congo, Ndjili, 1 ♂, 5.iii.1968 (*J. van Ryn-Tormel*, MT 135900); Kivu, Plaine de la Rusisi, with *Camponotus* ant, 2 ♂, 4 ♀, 17.ii.1967 (*S. Nadani*, MT 133745); Leopoldville, 1 ♂, 1942 (*A. Lyrer-sonne*, MT 58100–33) (MRAC, Tervuren).

### *Myrmarachne legon* sp. n.

(Figs 41A–C; 42A–K; Pl. 4b, d, f)

**DIAGNOSIS.** *Myrmarachne legon* is a very variable species closely related to *M. bamakoi* Berland & Millot, *M. tristis* (Simon) and *M. marshalli* Peckham & Peckham. It is separated from *bamakoi* by the shape of the carapace (Fig. 41A–C) and from *tristis* by the presence of four trichobothria in the mid-dorsal region of the postocular constriction, the finer abdominal pubescence, the poorly developed flange (Fig. 42J), indistinct epigyne and rather small lateral pouches (Fig. 42H, K). From *marshalli* it is separated by the abdominal pubescence and absence of a longitudinal fringe of whitish hairs on the thorax (Pl. 4b); the palp is relatively small and in larger specimens the tegulum is small relative to the cymbium (Fig. 42G); the epigyne is distinguished by its smaller size and simpler spermatheca.

**MALE.** *Carapace* (Figs 41A–C; 42A, I; Pl. 4b, d, f): punctured-reticulate with papillae on thoracic part; brown-black with very fine scattered white hairs and white wedge-shaped bands in constriction. *Eyes*: anteriors subcontiguous with apices procurved, fringed with white hairs. *Clypeus*: grey haired. *Chelicerae* (Fig. 42E, F): rugulose with furrows; orange-brown tinged with black with blackish lateral keels; fang apophysis present. *Maxillae and Labium*: brown-black with



inner margins of maxillae and labial tip orange-brown. *Sternum* (Fig. 42D): orange tinged with black. *Abdomen* (Figs 41A–C; 42A, I): mottled brownish black; scuta mahogany brown tinged with black, shiny; very thinly clothed with very fine brownish hairs. *Legs*: legs I tarsi and metatarsi brown-black; tibiae and patellae yellow-brown with black lateral streaks; other segments dark brownish orange. Legs II as I but tarsi and metatarsi yellow-brown. Legs III dark brownish orange with tarsi and metatarsi lighter. Legs IV as III but patellae and trochanters marked with yellowish. Ventral spination of legs I: metatarsi 2–2, tibiae usually 2–2–2, patellae 0. *Palp* (Fig. 42G, J): tibial apophysis distally hooked; flange poorly developed, at least in lateral view; proximal depression fringed with stout setae; tegulum relatively small in moderate-sized specimens but less distinctive in dwarfs.

*Dimensions*: total length 3.16–6.24 mm, carapace length 1.48–2.84 mm. *Ratios*: AM : AL : PM : PL: 9.5 : 4.5 : 1.5 : 5, AL–PM–PL: 6–8, a: 0.84–1.02, b: 0.97–1.02, c: 0.38–0.40, d: 0.45–0.87, e: 0.80–1.0 (10 ♂ examined).

**FEMALE.** *Carapace* (Fig. 42C, B): punctured-reticulate; brown-black with very scattered, fine brownish hairs in eye region and fine whitish ones on thoracic part with white wedge-shaped bands in constriction. *Eyes*: more or less as in ♂. *Clypeus*: as in ♂. *Chelicerae*: rugulose; orange to orange-brown, shiny; promargin with 7 or 8 teeth, retromargin with 7–9. *Maxillae and Labium*: as in ♂. *Sternum*: as in ♂. *Abdomen* (Fig. 42C): mottled brownish black with brown patch anteriorly; clothed with fine, brownish hairs with whitish bands in constriction. *Legs*: leg I tarsi and metatarsi brown black; tibia, patellae and femora yellow-brown with black lateral streaks; trochanters and coxae yellow-brown. Legs II yellow-brown with black lateral streaks on tibiae and patellae, and inside femora with a blackish spot on coxae. Legs III dark brown but tarsi and metatarsi yellow-brown. Legs IV as III but tarsi and metatarsi dark brown, patellae and trochanters marked with yellowish. Ventral spination of legs I: as in ♂. *Epigyne* (Fig. 42H, K):

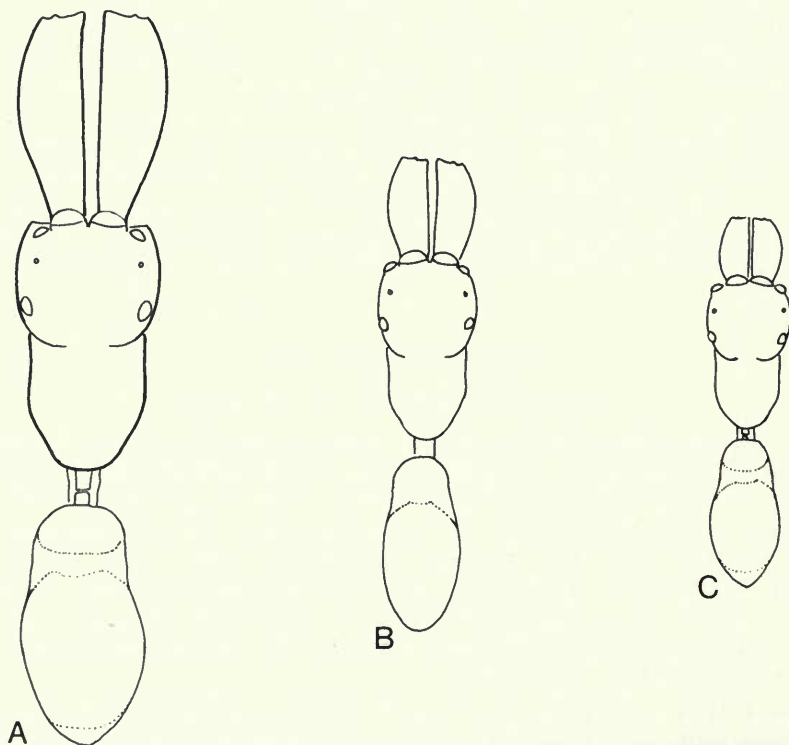
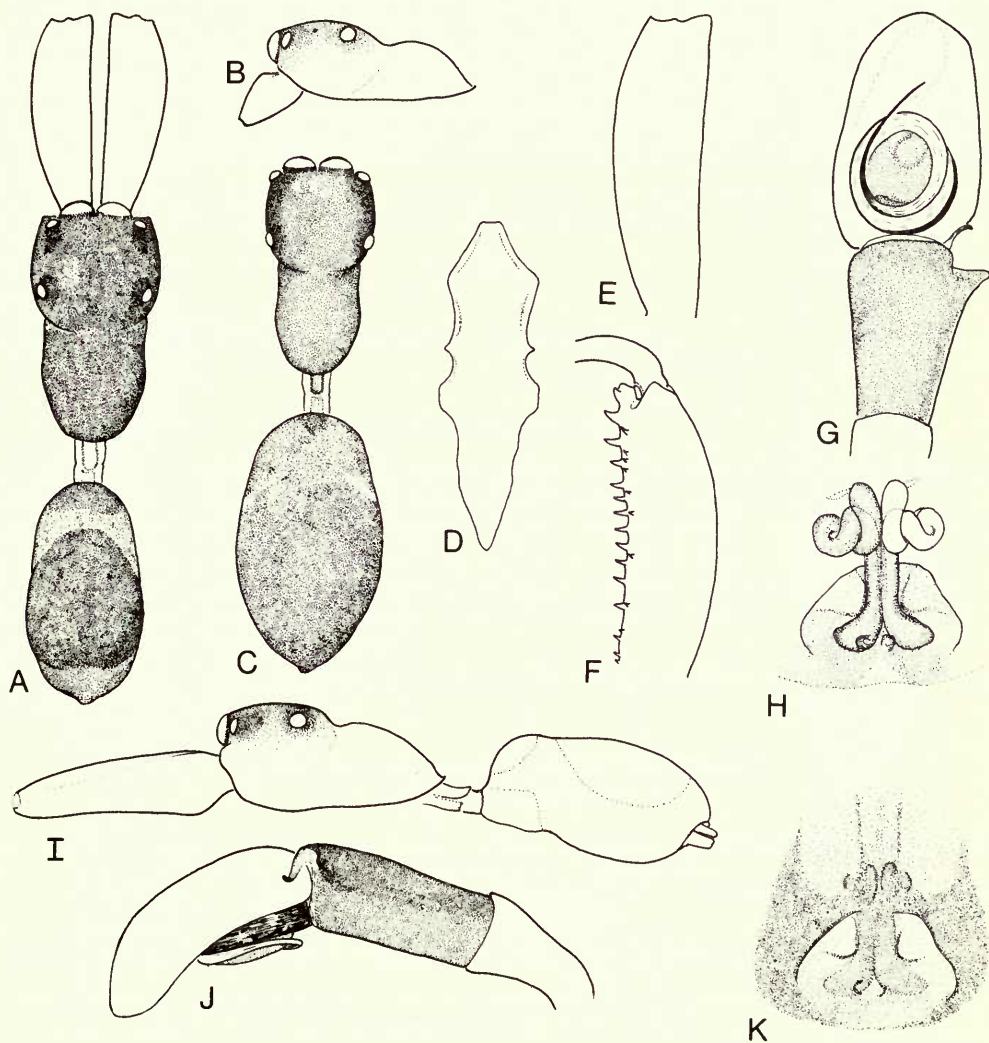

**Fig. 41** *Myrmarachne legon* sp. n. Paratype males from Lamto Field Station, Ivory Coast, drawn to scale. (A, B, C) 3 males showing allometric growth from a series of 4 males which were observed in *copula* (M J. L. Ledroux).

small, usually ill-defined; lateral pouches small, spermathecae relatively simple but configuration a little variable.

*Dimensions*: total length 4.48–6.0 mm, carapace length 2.16–2.6 mm. *Ratios*: AM:AL:PM:PL: 9.5:5:1:5, AL-PM-PL: 6.5–6.5; a: 1.02, b: 1.02–1.04, c: 0.36–0.40, e: 0.83–0.90 (8 ♀ examined).

**BIOLOGY.** *M. legon* has been found in association with *Crematogaster* ants and with *Camponotus acvapimensis* Mayr in Ghana and is preyed upon by *Pison* wasps (M. Edmunds, pers. comm.). Courtship behaviour has been studied by J. C. Ledroux at Lamto field station in the Ivory Coast (pers. comm.). The male advances softly, tapping the ground with legs I held in front and the consenting female advances a little and flattens herself to the ground. The male passes over her and with the thorax close to the abdomen, he leans to one side and inserts the palp. After insertion the male leans over to the other side and inserts the other palp. When the female is less consenting she faces the male and flees. If she is not receptive she approaches the male with chelicerae and



**Fig. 42** *Myrmarachne legon* sp. n. Holotype ♂: (A) dorsal view; (D) sternum; (E) chelicera dorsal view; (F) chelicera, ventral view; (G) palp, ventral view; (I) lateral view; (J) palp, lateral view. Paratype ♀: (B) carapace, lateral view; (C) dorsal view; (H) vulva, ventral view; (K) epigyne, ventral view.

fangs spread out and simulates a jump towards the male (advancing and recoiling immediately in the same gesture). The male normally flees but if the female is too aggressive the male in its turn becomes aggressive and simulates attack by opening and closing the chelicerae and fangs; the menacing position lasting for several seconds.

*M. legon* made no attempt to mate with female *M. foenisex* which were immediately aggressive.

DISTRIBUTION. Ghana, Ivory Coast.

MATERIAL EXAMINED. Holotype ♂, GHANA: Legon, on tree with *Crematogaster* ants, vii.1973 (*M. Edmunds*, vial 31) (BMNH, reg. no. 1975.1.31.40). Paratypes. GHANA: same data as holotype 2 ♀; Legon, with *Camponotus acvapimensis*, 1 ♂, 1972 (*M. Edmunds*, vial 26), 4 ♂, 2 ♀ (*M. Edmunds*, vial 38), 1 ♂, 8.iii.1970 (*M. Edmunds*); Legon, from wasp cells, 2 ♀, 13.i.1971 (*M. Edmunds*, vial 1); Legon, from 5 wasp cells, 4 ♀, 23 immatures (various instars), 11.ii.1971 (*M. Edmunds*); Accra, on *Calotropis procera*, 1 ♀, 12.x.1971 (*M. Edmunds*, vial 25) (BMNH). IVORY COAST: Nr Bandama, Lamto Field Station, 4 ♂, 3 ♀, between 10 and 18.i.1975 (*J. L. Ledroux*) (MNHN, Paris).

ETYMOLOGY. The specific name is a noun in apposition after the type-locality.

REMARKS. In his studies on courtship behaviour M J. L. Ledroux paired 3 males and 3 females in the following combinations: ♀2 with ♂1 (twice), ♂3 and ♂4; ♀5 with ♂4 and ♂7; ♀6 with ♂4. One of the females (♀6) differs from the rest by having distinctive coarse white hairs on the thorax, but it is in all other respects similar, and there can be little doubt that it is conspecific with *M. legon*. The specimen could be aberrant or even represent a polymorphic form.

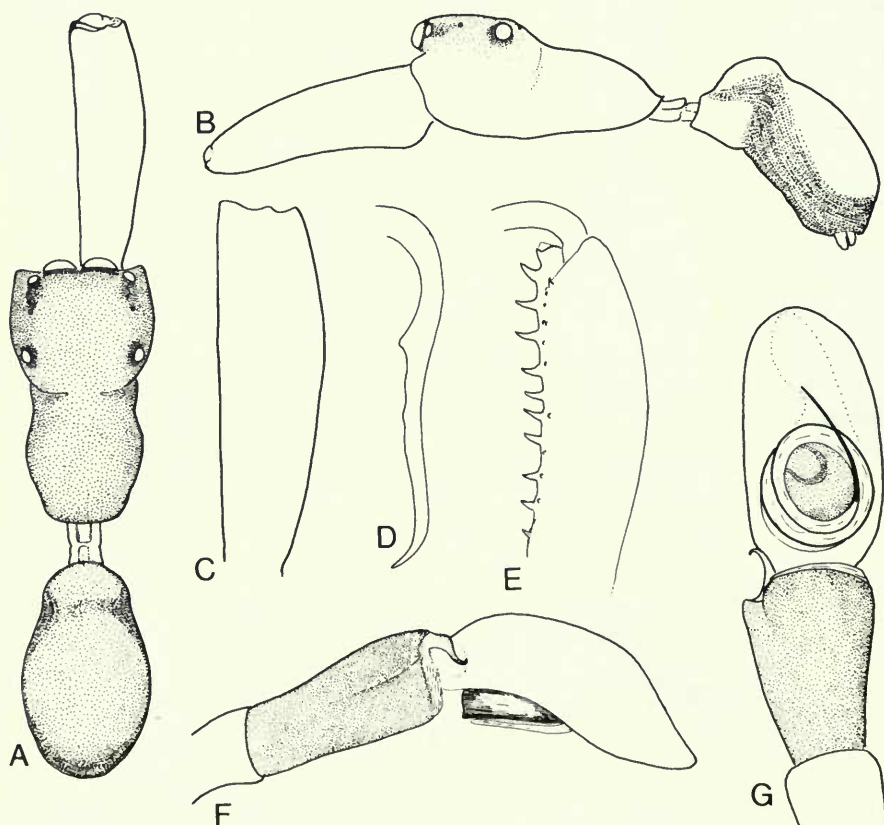

Fig. 43 *Myrmarachne bamakoi* Berland & Millot. Holotype ♂: (A) dorsal view; (B) lateral view; (C) chelicera, dorsal view; (D) fang; (E) chelicera, ventral view; (F) palp, lateral view; (G) palp, ventral view.



*Myrmarachne bamakoi* Berland & Millot

(Fig. 43A–G)

*Myrmarachne bamakoi* Berland & Millot, 1941 : 404, fig. 94, ♂. Holotype ♂, Mali, Bamako (MNHN, Paris) [Examined]. Roewer, 1954 : 942; 1965 : 72, fig. 58.

**DIAGNOSIS.** *Myrmarachne bamakoi* is a distinctive species readily distinguished from other species in the *tristis*-group by the shape of the carapace (Fig. 43A). Its affinities are uncertain but it is probably related to *M. dundoensis* sp. n. a member of the *formicaria*-group.

**FEMALE.** Unknown.

**MALE.** *Carapace* (Fig. 43A, B): finely punctured-reticulate; orange-brown with scattered light brown hairs and white haired in constriction. *Eyes*: anteriors subcontiguous with apices slightly procurved, fringed with whitish hairs. *Clypeus*: fringed with light brownish hairs. *Chelicerae* (Fig. 43C–E): finely rugulose; yellow-brown; fang apophysis present. *Maxillae and Labium*, yellow-brown tinged with black, but inner distal margin and labial tip lighter. *Sternum*: elongate, narrow; yellow-brown. *Abdomen* (Fig. 43A, B): mottled yellow-brown and black with yellow-brown scuta; sparsely clothed with light orange-brown hairs. *Legs*: slender; light brown tinged with black but tarsi and metatarsi II whitish. Ventral spination of legs I: metatarsi 2–2, tibiae 2–2–2–2, patellae 0. *Palp* (Fig. 43F, G): tibial apophysis relatively long and slender with distal hook; flange poorly developed; proximal ectal margin of cymbium depressed, fringed with moderately stout setae.

*Dimensions*: total length 5.7 mm, carapace length 2.9 mm. *Ratios*: AM : AL : PM : PL : 10.5 : 5 : 1.3 : 5.5, AL–PM–PL : 8–9.5; a : 0.82, b : 0.96, c : 0.37, d : 0.96, e : 1.03 (1 ♂ examined).

**BIOLOGY.** Unknown.

**DISTRIBUTION.** Mali.

**MATERIAL EXAMINED.** Holotype ♂, data given in synonymy.

**The *formicaria*-group**

This group takes its name from a European species *M. formicaria* (DeGeer) and may be distinguished by the following characters. Males: tibial apophysis more or less sinuous (Fig. 47C); flange poorly developed or lacking in most Ethiopian species but well developed in *M. formicaria* and in some individuals of *M. dundoensis* sp. n. (Pl. 5); proximal ectal margin of cymbium not depressed or protuberant; seminal reservoir medium to small, not marginate (Figs 59C; 57L). Females: median subtriangular pouch present; spermathecae looped or twisted (Fig. 46J); proximal seminal ducts poorly defined.

One Madagascan and 12 African species belong to this group which is also known to occur in the Palaearctic and Oriental regions.

*Myrmarachne cowanii* (Peckham & Peckham)

(Figs 44A–E; 45A–G)

[*Salticus augustus* Peckham & Peckham, 1892 (in part) ♂ variety with long falces, p. 24, pl. 1, figs 5a, 5b, 5c, Madagascar (MCZ, Harvard). Misidentification.] [Examined.]

*Iola cowanii* Peckham & Peckham, 1892 : 75, pl. 6, figs 3, 3a, 3b, 3c, ♀. LECTOTYPE ♀ (here designated), Madagascar (MCZ, Harvard) [Examined]. Roewer, 1954 : 942.

*Myrmarachne cowani*: Bonnet, 1957 : 3001. Roewer, 1965 : 65. Prószyński, 1971b : 437.

The specimen regarded here as the male of this species was originally described by Peckham & Peckham as a variety of *Salticus augustus* Peckham & Peckham.

**DIAGNOSIS.** *M. cowanii* is a fairly distinctive species separated from other species in the *formicaria*-group by its elongate body (Figs 44A, E; 45A, G), proximally arched fang (Fig. 45C) and the form of the spermathecae (Fig. 44D). It is also the only species of this group known to occur in Madagascar.

FEMALE. *Carapace* (Fig. 44A, E): dark brownish orange with white, wedge-shaped bands in constriction. *Eyes*: anteriors subcontiguous with apices procurved, sparsely fringed with whitish hairs. *Chelicerae*: missing but originally described as 'rather long and stout, vertical, parallel'. *Sternum* (Fig. 44B): orange-brown. *Abdomen* (Fig. 44A, E): mottled brownish black with a pair of white spots on either side of constriction. *Legs*: missing but I and II originally described as light brown with legs III and IV dark brown. *Epigyne* (Fig. 44C, D): very pale and small; the convolutions of the spermathecae are not altogether characteristic of this group.

*Dimensions*: total length 5.1 mm, carapace length 1.88 mm. *Ratios*: AM : AL : PM : PL: 7.5 : 3.5 : 1 : 3, AL-PM-PL: 5-6; a: 1.0, b: 1.0, c: 0.38 (1 ♀ examined).

MALE. *Carapace* (Fig. 45A, C): punctured-reticulate in eye region; dark reddish orange with white, wedge-shaped bands in constriction. *Eyes*: as in ♀. *Clypeus*: white haired. *Chelicerae* (Fig. 45B-D): finely rugulose; orange; fang strongly arched proximally; apophysis present. *Sternum*: similar to ♂; orange with poorly defined margins. *Abdomen* (Fig. 45A, G): mottled brownish orange and black; scuta ill-defined, dark reddish tinged with black; a pair of white spots in constriction (originally a band). *Legs*: mostly detached but those which remain are generally orange-brown with femora III and IV darker. *Palp* (Fig. 45E, F).

*Dimensions*: total length 4.9 mm, carapace length 1.96 mm. *Ratios*: AM : AL : PM : PL: 8 : 4 : 1 : 4, AL-PM-PL: 5-6.5; a: 0.96, b: 0.98, c: 0.38, d: 1.28 (1 ♂ examined).

In the female the carapace and abdomen were originally described as black with a white band around the abdominal constriction. The epigyne has probably faded and may look quite different in fresh specimens.

BIOLOGY. Unknown.

DISTRIBUTION. Madagascar.

MATERIAL EXAMINED. Lectotype ♂, data given in synonymy. MADAGASCAR: 1 ♂ (MCZ, Harvard).

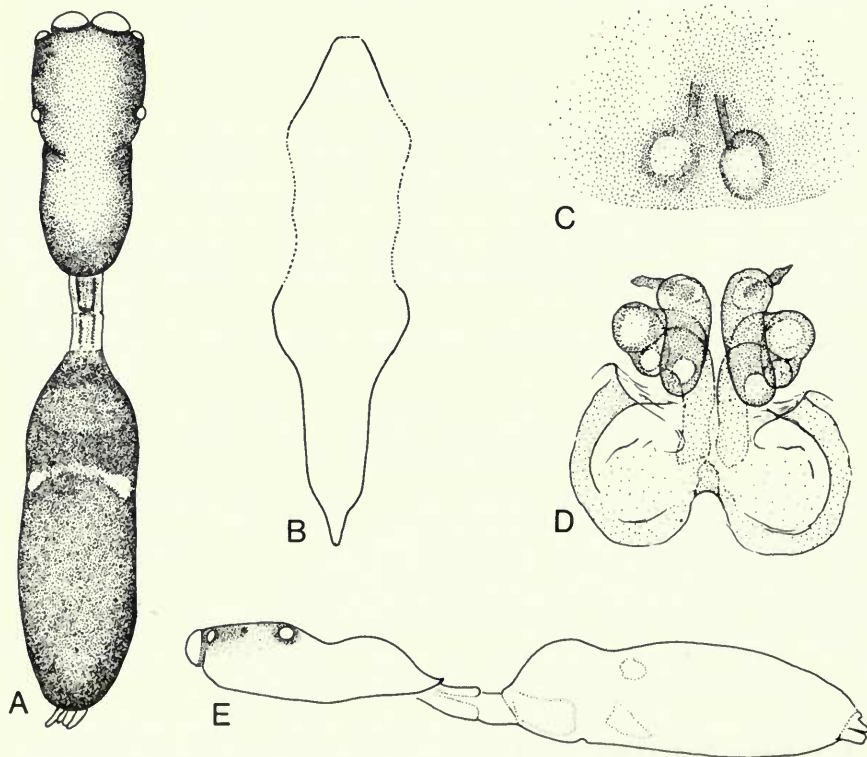

Fig. 44 *Myrmarachne cowanii* (Peckham & Peckham). Lectotype ♀: (A) dorsal view; (B) sternum; (C) epigyne, ventral view; (D) vulva, ventral view; (E) lateral view.

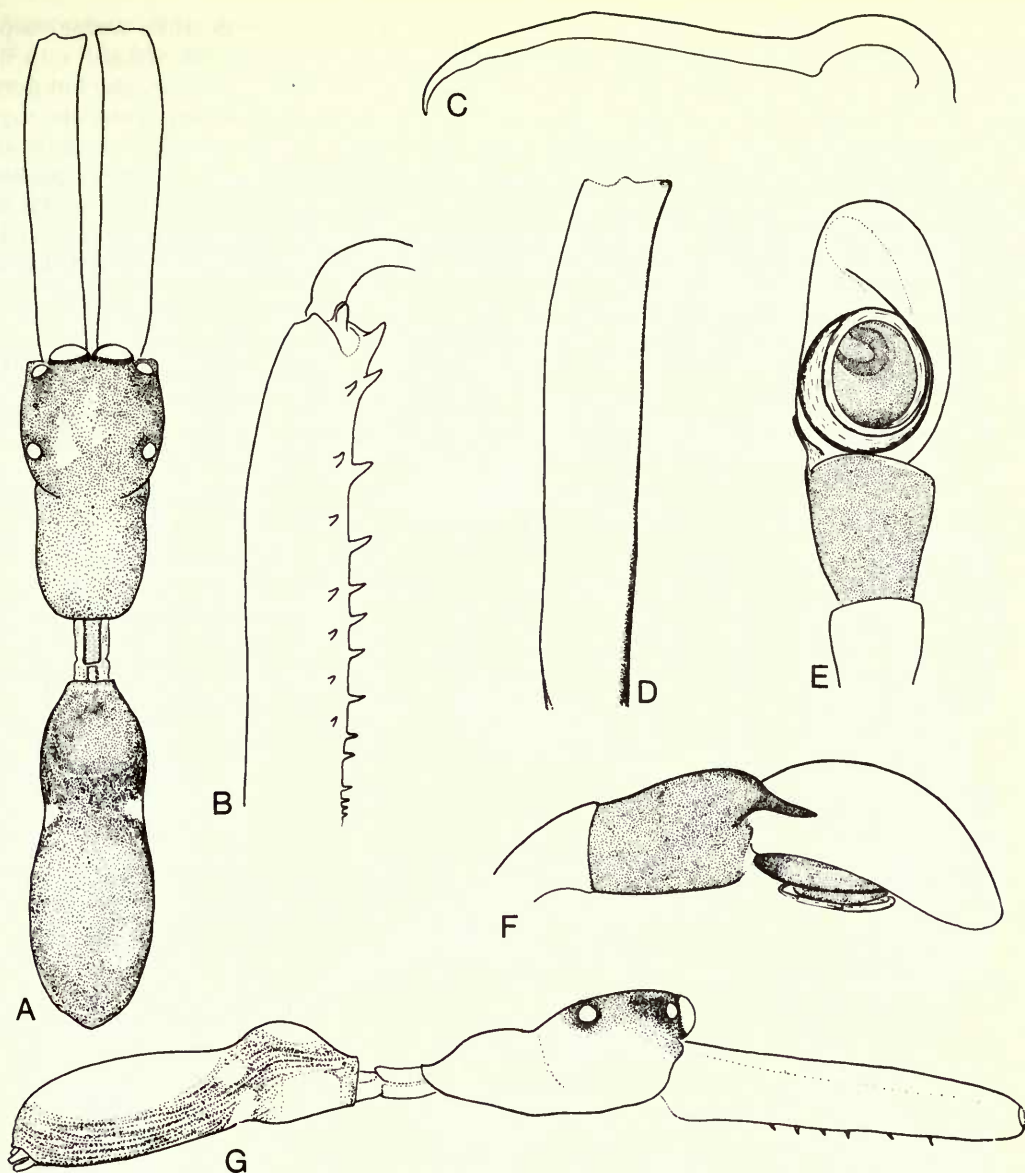

Fig. 45 *Myrmarachne cowanii* (Peckham & Peckham). ♂: (A) dorsal view; (B) chelicera, ventral view; (C) fang; (D) chelicera, dorsal view; (E) palp, ventral view; (F) palp, lateral view; (G) lateral view.

*Myrmarachne solitaria* Peckham & Peckham

(Fig. 46A-L)

*Myrmarachne solitaria* Peckham & Peckham, 1903 : 250, pl. 29, figs 5, 5a, ♂♀. LECTOTYPE ♂ (here designated), South Africa, Devil's Mountain, Cape Colony (MCZ, Harvard) [Examined].

*Myrmarachne solitaria*: Roewer, 1954 : 944. Bonnet, 1957 : 3013. Roewer, 1965 : 71. Prószyński, 1971b : 440.

DIAGNOSIS. *Myrmarachne solitaria* is closely related to *M. kiboschensis* Lessert, *M. leleupi* sp. n. and *M. uelensis* sp. n., but may be distinguished by the lack of fang apophyses (Fig. 46E) and looped spermathecae (Fig. 46J).



MALE. *Carapace* (Fig. 46A, H): punctured reticulate; orange-brown with white wedge-shaped bands in constriction. *Eyes*: anterior subcontiguous with apices procurved, fringed with fine white hairs. *Clypeus*: white haired. *Chelicerae* (Fig. 46E, F, K): more or less horizontal but dorsal surface with a marked inward slope; rugulose with furrows; orange-brown; fang apophysis lacking. *Abdomen* (Fig. 46A, H): mottled brownish black with shiny orange-brown scuta and scattered white hairs in constriction. *Legs*: femora I slightly enlarged. Legs I with tarsi, patellae, trochanters and coxae yellow-brown; other segments light brown. Legs II yellow-brown but femora pale brown. Legs III–IV light brown with oblique yellow-brown markings on patellae IV. Ventral spination of legs I: metatarsi 2–2, tibiae 2–2–2–1–2, patellae 1. *Palp* (Fig. 46B, L): the tegulum has a very slight distal cleft.

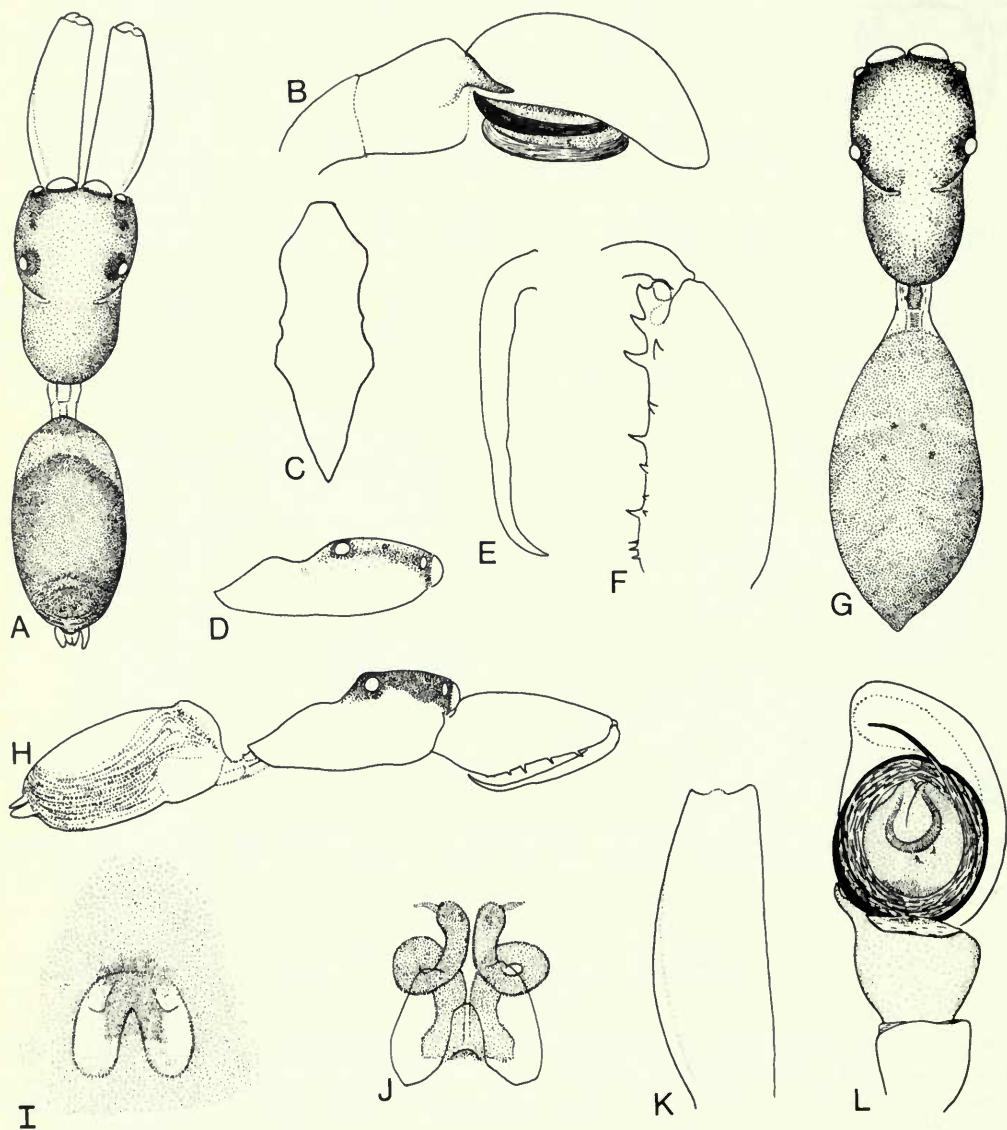

Fig. 46 *Myrmarachne solitaria* Peckham & Peckham. Lectotype ♂: (A) dorsal view; (B) palp, lateral view; (C) sternum; (E) fang; (F) chelicera, ventral view; (H) lateral view; (K) chelicera dorsal view; (L) palp, ventral view. Paralectotype ♀: (D) carapace, lateral view; (G) dorsal view; (I) epigyne, ventral view; (J) vulva, ventral view.

*Dimensions*: total length 4.0 mm, carapace length 1.86 mm. *Ratios*: AM : AL : PM : PL: 7 : 4 : 1 : 4.2, AL-PM-PL: 6-6; a: 0.93, b: 0.98, c: 0.41, d: 0.75, e: 0.88 (1 ♂ examined).

**FEMALE.** *Carapace* (Fig. 46D, G): orange-brown but dorsal margins of constriction darker. *Eyes*: more or less as in ♂. *Clypeus*: as in ♂. *Chelicerae*: rugulose; light orange, shiny; promargin with 6 teeth, retromargin with 5 or 6. *Sternum*: yellow brown. *Abdomen* (Fig. 46G): greyish brown with whitish hairs in area of constriction. *Legs*: legs I yellow-brown with blackish sides excepting tarsi and coxae. Legs II light yellowish with black streaks on sides of tibiae and patellae and inside of femora. Legs III tarsi and metatarsi yellow-brown; tibiae yellow-brown with black sides; patellae black-brown dorsally, yellowish ventrally; other segments brownish black. Legs IV tarsi and metatarsi distally yellow-brown; metatarsi proximally and femora brown-black; patellae brown-black marked with yellowish; coxae and trochanters light yellowish with darker apices. Ventral spination of legs I as in ♂ but tibiae with 2-2-2 spines. *Epigyne* (Fig. 46I, J): small and pale, the spermathecae simply looped.

*Dimensions*: total length 4.40 mm, carapace length 1.72 mm. *Ratios*: AM : AL : PM : PL: 8 : 4 : 1 : 4, AL-PM-PL: 6-6; a: 1.02, b: 1.02, c: 0.43, e: 0.72 (1 ♀ examined).

**BIOLOGY.** Unknown.

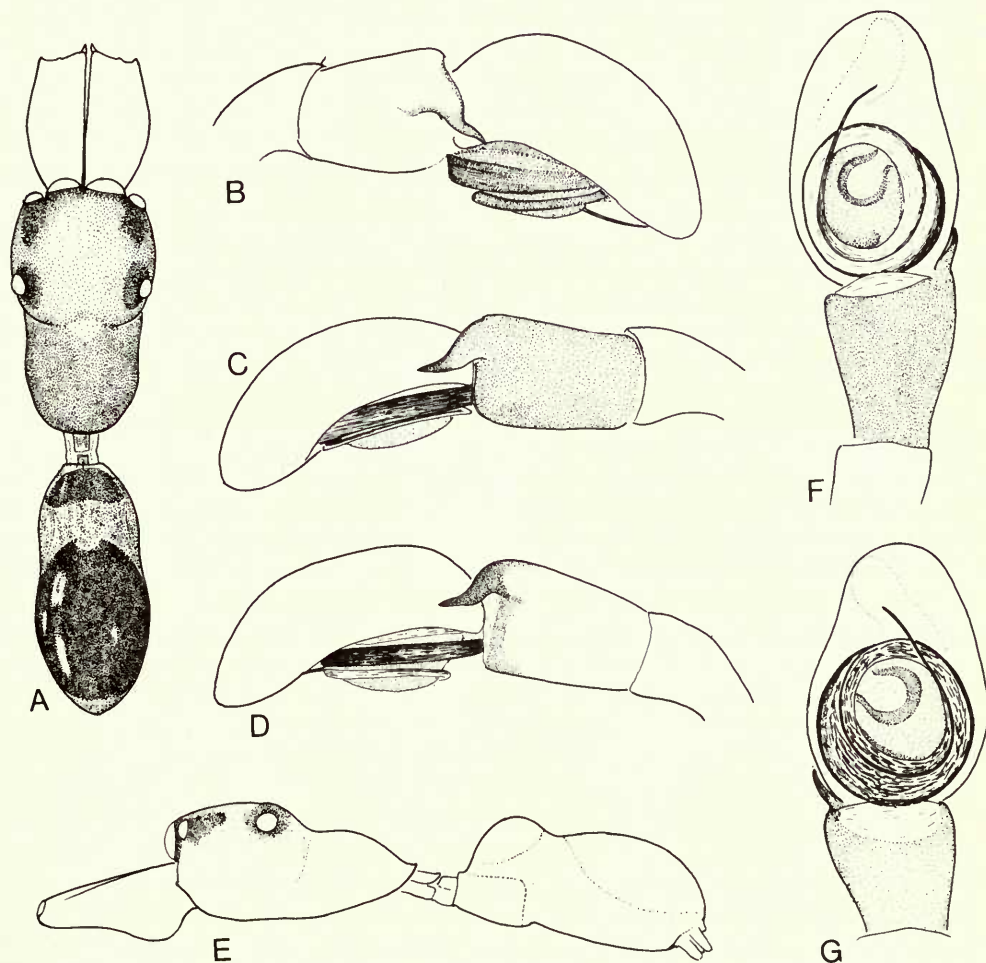

**Fig. 47** *Myrmarachne kiboschensis* Lessert. Lectotype ♂: (B) palp, lateral view; (G) palp, ventral view. ♂ from Botswana: (A) dorsal view; (C) palp, lateral view; (F) palp, ventral view; (E) lateral view. ♂ from Sudan, (D) palp, lateral view.



DISTRIBUTION. South Africa.

MATERIAL EXAMINED. Lectotype ♂, data given in synonymy. Paralectotype: SOUTH AFRICA: Retreat Flats, Cape Colony, 1 ♀ (MCZ, Harvard).

*Myrmarachne kiboschensis* Lessert

(Fig. 47A-G; 48A-K)

*Myrmarachne kiboschensis* Lessert, 1925a : 441, figs 18-22, ♂♀. LECTOTYPE ♂ (here designated), Tanzania, Kiboscho (NR, Stockholm) [Examined]. Roewer, 1954 : 943. Bonnet, 1957 : 3007. Roewer, 1965 : 43, fig. 50. Prószyński, 1971b : 438.

*Myrmarachne diversicoxis* Caporiacco, 1947 : 227, pl. 2, fig. 62, ♀. Holotype ♀, Tanzania, Moshi (TM, Budapest) [Examined]. Roewer, 1954 : 942; 1965 : 44. Syn. n.

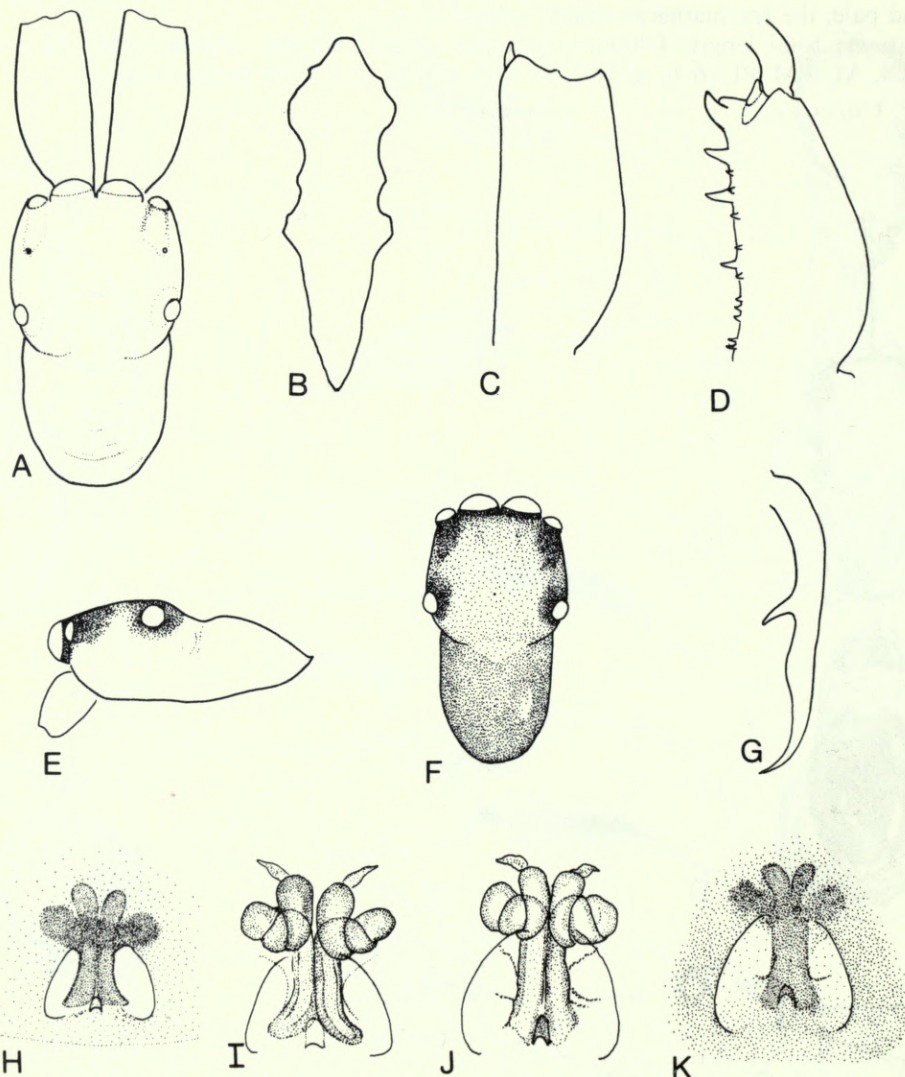

Fig. 48 *Myrmarachne kiboschensis* Lessert. ♂ from Sudan: (A) carapace, dorsal view; (B) sternum; (C) chelicera, dorsal view; (D) chelicera, ventral view; (G) fang. Paralectotype ♀: (E) carapace, lateral view; (F) carapace, dorsal view; (H) epigyne, ventral view; (I) vulva, ventral view. Holotype, female of *M. diversicoxis* Caporiacco: (J) vulva, ventral view; (K) epigyne, ventral view.



**DIAGNOSIS.** *M. kiboschensis* is closely related to *M. solitaria* Peckham & Peckham, *M. leleupi* sp. n. and *M. uelensis* sp. n. Males are separated by the combination of palpal structure (Fig. 47B–D, F, G), stout, fang apophysis (Fig. 48G) and lack of abdominal pubescence. Females are distinguished by the small median pouch and simple but somewhat tightly twisted spermathecae (Fig. 48H–K).

**MALE.** *Carapace* (Figs 47A, E; 48A): punctured-reticulate; orange-brown or reddish brown tinged with black; very sparsely clothed with fine blackish hairs but white wedge-shaped bands apparently lacking. *Eyes*: anteriors subcontiguous with apices weakly procurved, sparsely fringed with white hairs. *Clypeus*: sparsely fringed with long, fine hairs. *Chelicerae* (Fig. 48C, D, G): rugulose with furrows; orange-brown mottled with blackish, shiny; fang apophysis present, well developed. *Maxillae and Labium*: orange-brown tinged with black. *Sternum* (Fig. 48B): light orange-brown tinged with black, margins darker. *Abdomen* (Fig. 47A): blackish with glossy black scuta and oblique yellowish bands on the sides. *Legs*: legs I with tarsi whitish yellow; metatarsi blackish; tibiae and patellae orange-brown with black lateral streaks; femora black; trochanters and coxae yellow-brown, the latter with black sides. Legs II as I but metatarsi and femora yellow-brown with blackish lateral streaks. Legs III tarsi yellowish; metatarsi and tibiae yellow-brown with black sides; patellae and femora blackish; trochanters and coxae blackish but venter mottled black and yellow-brown. Legs IV as III but metatarsi and tibiae black; patellae black, marked with yellowish; trochanters and coxae yellow with black sides. Ventral spination of legs I: metatarsi 2–2, tibiae 2–2–2–2, patellae 1. *Palp* (Fig. 47B–D, F, G).

*Dimensions*: total length 3.48–5.56 mm, carapace length 1.64–2.56 mm. *Ratios*: AM : AL : PM : PL: 10 : 6 : 1.4 : 6, AL–PM–PL: 8.5–8; a: 0.94–1.02, b: 0.95–1.02, c: 0.40–0.46, d: 0.44–0.59, e: 0.84–0.92 (10 ♂ examined).

**FEMALE.** *Carapace* (Fig. 48E, F): as in ♂. *Eyes*: more or less as in ♂. *Clypeus*: as in ♂. *Chelicerae*: rugulose with weak, proximal, prolateral keels; orange, shiny; promargin with 4 teeth, retromargin with 8. *Maxillae and Labium*: as in ♂. *Sternum*: as in ♂. *Abdomen*: black with a golden sheen with oblique yellowish bands on the sides and faint dorsal chevrons. *Legs*: as in ♂ but venter of femora I distally light yellow. *Epigyne* (Fig. 48H–K): spermathecae closely looped.

*Dimensions*: total length 3.72–6.24 mm, carapace length 1.72–2.44 mm. *Ratios*: AM : AL : PM : PL: 10 : 5 : 1.2 : 5.5, AL–PM–PL: 8–7; a: 1.02–1.03, b: 1.04–1.06, c: 0.42–0.45, e: 0.81–0.95 (9 ♀ examined).

Colour of preserved specimens shows considerable variation and ranges from light yellow to blackish and some individuals have a distinct reddish tinge especially on the carapace. In paler specimens the anterior scutum often loses its black gloss, and while the posterior scutum may be somewhat reduced anteriorly, it retains its glossy black colour except in older preserved specimens or newly moulted individuals. A male from Sudan has the carapace differently shaped with transverse grooves on the thorax (Fig. 48A), also the tibial apophysis is slightly more sinuous.

**BIOLOGY.** *M. kiboschensis* has been collected from the same square metre plot of *Setaria* grassland as *M. foreli* Lessert, *M. dundoensis* sp. n., and *M. wira* sp. n. It has also been taken with *Campanotus* ants of the *vetitus*-group and with the ant *Odontomachus troglodytes* Santschi.

In courtship the ♂ approaches the ♀ with a side-stepping movement but with the front legs bunched up, the tibiae and patellae being parallel and almost touching the chelicerae. In *copula* the ♂ lies above the ♀ but facing in the opposite direction, both tilting to one side when the palp is inserted (F. Wanless, unpublished observations).

**DISTRIBUTION.** Botswana, Kenya, Sudan, Tanzania.

**MATERIAL EXAMINED.** Type data given in synonymy. **BOTSWANA**: Island Safari Lodge, nr Maun, 1 ♀, 21.ix.1975 (A. Russell-Smith); Mboma Island, flood plain grassland, 1 ♀, 16.x.1975 (A. Russell-Smith), 1 ♂, 14.iii.1976 (A. Russell-Smith & F. Wanless); Mushu, Mushu Bridge, flood plain grassland, 1 ♀, 10.iii.1976 (A. Russell-Smith & F. Wanless); Maun, dried out lagoon, nr Maphaneng Pan, 1 ♀, 27.ii.1976 (A. Russell-Smith); Maun, Thamalakane River, grassland, 8 ♀, 16 ♂, 14.i–23.iii.1976 (A. Russell-Smith & F. Wanless) (BMNH). **KENYA**: Naro Moru, swept from bushes and vegetation by the side of the river, 1 ♀, 17.viii.1974 (J. & F. Murphy) (BMNH). **SUDAN**:

between Malakal and Shambe, 1♂, 8.xii.1961 (*J. Cloudsley-Thompson*, MT 120808.1) (MRAC, Tervuren).

*Myrmarachne leleupi* sp. n.

(Figs 49A, B, E; 50B, D, E, G, I)

DIAGNOSIS. *M. leleupi* is closely related to *M. solitaria* Peckham & Peckham, *M. kiboschensis* Lessert and *M. uelensis* sp. n., but may be distinguished by the combination of shallow tegular cleft (Fig. 49B), abdominal pubescence, fang apophysis (Fig. 50B) and slight, distal, cheliceral constriction (Fig. 50I).

FEMALE. Unknown.

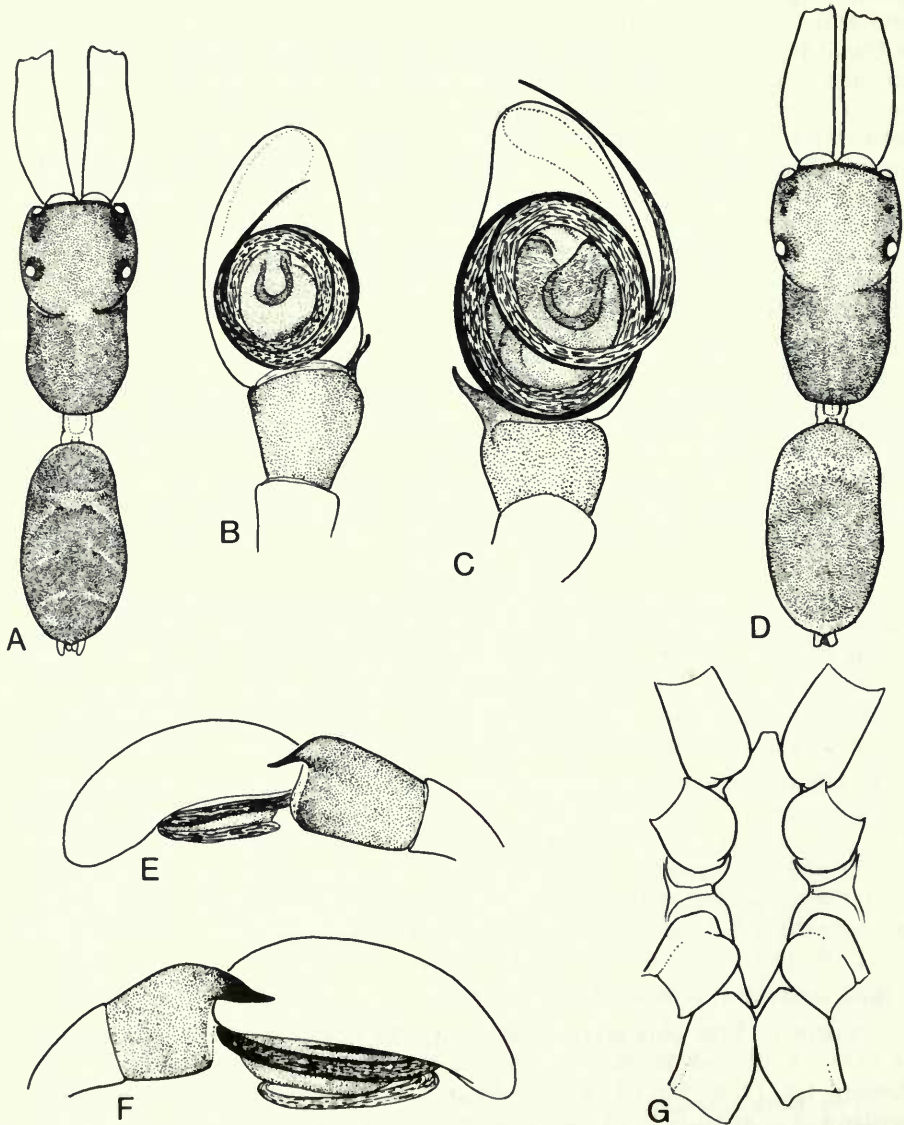

Fig. 49 (A, B, E) *Myrmarachne leleupi* sp. n. Holotype ♂: (A) dorsal view; (B) palp, ventral view; (E) palp, lateral view. (C, D, F, G) *Myrmarachne uelensis* sp. n. Holotype ♂: (C) palp, ventral view; (D) dorsal view; (F) palp, lateral view; (G) sternum.

MALE. *Carapace* (Fig. 49A; 50D): punctured-reticulate; dark brown with scattered white hairs. *Eyes*: anteriors subcontiguous with apices procurved, fringed with fine white hairs. *Clypeus*: white haired. *Chelicerae* (Fig. 50B, G, I): rugulose with furrows; orange-brown with blackish lateral keels; fang apophysis present. *Maxillae and Labium*: orange-brown tinged with blackish. *Sternum* (Fig. 50E): orange-brown tinged with black. *Abdomen* (Fig. 49A; 50E): mottled blackish brown; scuta poorly defined, orange-brown tinged with blackish, a golden sheen posteriorly; clothed with whitish hairs forming rather vague transverse bands. *Legs*: legs I generally yellow-brown with blackish sides but femora brown-black, and coxae yellowish. Legs II yellow-brown but with blackish sides on femora, trochanters and coxae. Legs III tarsi yellow-brown; metatarsi yellow-brown with blackish sides proximally; tibiae and patellae blackish but ventral and inner sides yellow-brown; other segments blackish brown. Legs IV tarsi black becoming yellow-brown distally; metatarsi, tibiae and femora brown-black; patellae brown-black but venter yellowish; trochanters and coxae light yellow with blackish sides. Ventral spination of legs I: metatarsi 2-2, tibiae 2-2-2-2-2, patellae 1. *Palp* (Fig. 49B, E).

*Dimensions*: total length 5.6 mm, carapace length 2.72 mm. *Ratios*: AM : AL : PM : PL: 10.5 : 5.5 : 1 : 6.5, AL-PM-PL: 7.5-7; a: 0.94, b: 0.97, c: 0.45, d: 0.73, e: 0.92 (1 ♂ examined).

BIOLOGY. Unknown.

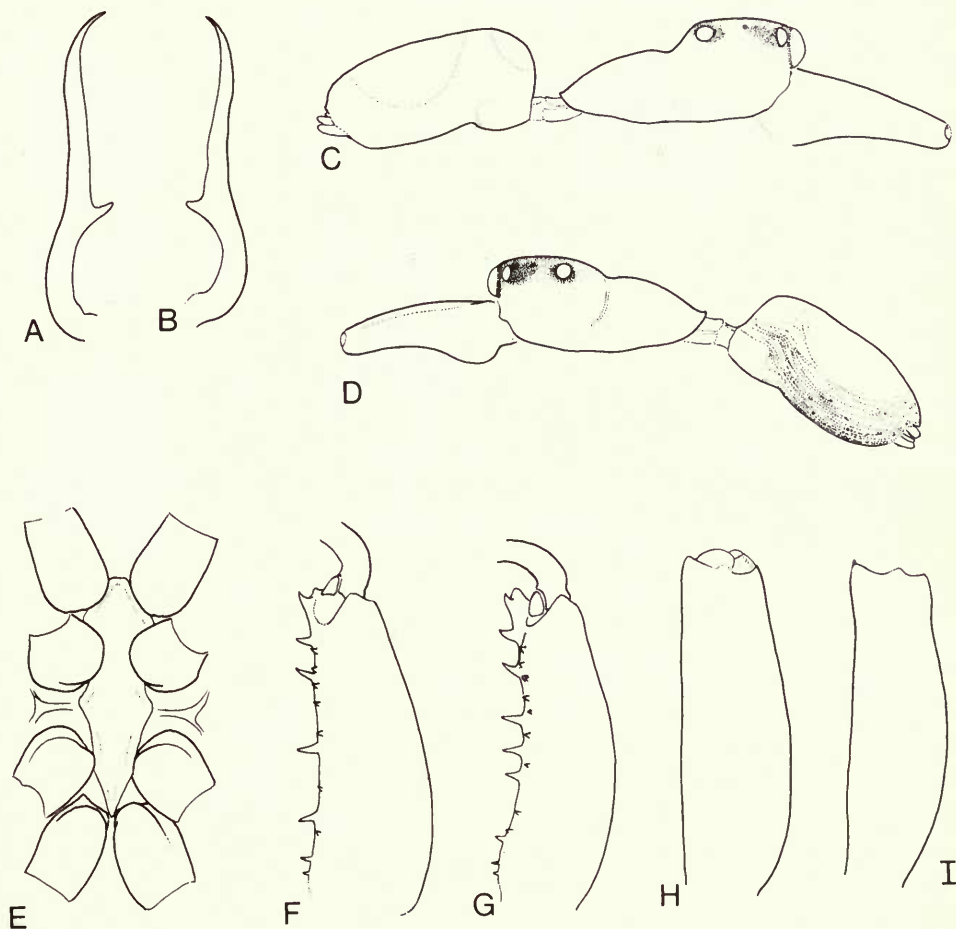

Fig. 50 (B, D, E, G, I) *Myrmarachne leleupi* sp. n. Holotype ♂: (B) fang; (D) lateral view; (E) sternum; (G) chelicera, ventral view; (I) chelicera, dorsal view. (A, C, F, H) *Myrmarachne uelensis* sp. n. Holotype ♂: (A) fang; (C) lateral view; (F) chelicera ventral view; (H) chelicera, dorsal view.



DISTRIBUTION. South Africa.

MATERIAL EXAMINED. Holotype ♂, South Africa, Natal, Pietermaritzburg, x.1960 (*N. Leleup*, MT 132196) (MRAC, Tervuren).

ETYMOLOGY. This species is named in honour of the collector M N. Leleup whose African work has considerably enriched the collections of the Musée Royal de l'Afrique Central.

*Myrmarachne uelensis* sp. n.

(Figs 49C, D, F, G; 50A, C, F, H)

DIAGNOSIS. *M. uelensis* is closely related to *M. leleupi* sp. n. from South Africa. It differs by having 3 or 4 pairs of ventral spines on metatarsi I; the tibial apophysis of the palp is heavier and the cleft in the anterior margin of the tegulum is deeper (Fig. 49C). These characters and the presence of abdominal pubescence also separates *M. uelensis* from *M. kiboschensis* Lessert.

FEMALE. Unknown.

MALE. *Carapace* (Figs 49D; 50C): punctured-reticulate; dark brown with scattered white hairs and white wedge-shaped bands in constriction. *Eyes*: anteriors subcontiguous with apices procurved. *Clypeus*: fringed with long white hairs. *Chelicerae* (Fig. 50A, F, H): rugulose with furrows; orange-brown, shiny; fang apophysis present. *Maxillae and Labium*: brownish black. *Sternum* (Fig. 49G): brown-black. *Abdomen* (Figs 49D; 50C): yellow-brown with orange-brown scuta; clothed with whitish pubescent hair. *Legs*: legs I with tarsi and metatarsi brownish; tibiae and patellae light brown with blackish sides; femora black with distal, venter light brown; trochanters and coxae dark brown. Legs II tarsi and metatarsi yellow-brown; tibiae and patellae yellow-brown with blackish sides; other segments blackish. Legs III blackish with tarsi and distal metatarsi yellow-brown. Legs IV as III but trochanters and venter of coxae yellow-brown. Ventral spination of legs I: metatarsi 2-2-2 and 2-2-2-2, tibiae 2-2-2-2-2, patellae 1. *Palp* (Fig. 49C, F): robust with relatively deep cleft in anterior margin of tegulum.

*Dimensions*: total length 4.3 mm, carapace length 2.2 mm. *Ratios*: AM : AL : PM : PL : 9 : 4.5 : 1 : 4.5, AL-PM-PL: 7-6, a: 1.0, b: 1.0, c: 0.39, d: 0.70, e: 1.09 (1 ♂ examined).

BIOLOGY. Unknown.

DISTRIBUTION. Zaire.

MATERIAL EXAMINED. Holotype ♂, ZAIRE, Moto, Upper Uele, xi.1922 (*L. Burgeon*, MT 130761) (MRAC, Tervuren).

ETYMOLOGY. The specific name refers to the type-locality.

*Myrmarachne dundoensis* sp. n.

(Figs 51A-I; 52A-E; Pl. 5a, b)

DIAGNOSIS. *M. dundoensis* is a distinctive member of the *formicaria*-group. Males are readily distinguished by the low value of ratio a, the relatively long thorax (Fig. 51A) and double fang apophysis (Fig. 51F). Females are separated by the form of the carapace (Fig. 52A, C), the darkening of tarsi I and epigyne structure (Fig. 52B, D, E). The affinities of *dundoensis* are uncertain but it could be confused with *M. bamakoi* Berland & Millot, a fairly distinctive member of the *tristis*-group.

MALE. *Carapace* (Fig. 51A, B): punctured-reticulate; brownish orange mottled with black; eye region darker with a metallic sheen; sparsely covered with whitish hairs and with white wedge-shaped bands in constriction. *Eyes*: anteriors subcontiguous with apices procurved, fringed with whitish hairs. *Clypeus*: fringed with long fine brownish hairs. *Chelicerae* (Fig. 51E, F, I): rugulose with furrows; brownish orange with black lateral keels; fang with 2 apophyses *Maxillae and Labium*: brownish orange. *Sternum* (Fig. 51H): brownish orange with blackish stippling. *Abdomen* (Fig. 51A, B): mottled brownish black with dark brown scuta; sparsely covered with whitish hairs. *Legs*: legs I tarsi and metatarsi orange suffused with black; tibiae and patellae orange-brown with black lateral streaks; remaining segments orange-brown suffused with black but

distal sides of femora light yellowish. Legs II tarsi and metatarsi orange-brown suffused with black; tibiae and patellae yellow-brown with black streaks; other segments yellow-brown suffused with black. Legs III tarsi yellow-brown; other segments blackish. Legs IV blackish with white trochanters and yellowish marks on patellae. Ventral spination of legs I: metatarsi 2-2, tibiae 2-2-2-2-2, patellae 1. *Palp* (Fig. 51C, D, G; Pl. 5a, b): the tibial apophysis is more sinuous in some individuals and the flange varies in its development.

*Dimensions*: total length 5.12-6.88 mm, carapace length 2.44-3.15 mm. *Ratios*: AM : AL : PM : PL: 10 : 4 : 1.7 : 4.5, AL-PM-PL: 7-8; a: 0.73-0.89, b: 0.89-0.98, c: 0.34-0.36, d: 0.59-0.73, e: 1.0-1.08 (10♂ examined).

*FEMALE. Carapace* (Fig. 52A, C): more or less as in ♂. *Eyes*: as in ♂. *Clypeus*: as in ♂. *Chelicerae*: rugulose; orange-brown, shiny; promargin with 7 teeth, retromargin with 6-8. *Maxillae and Labium*: as in ♂. *Sternum*: blackish stippled with orange-brown. *Abdomen*: greyish black clothed with fine whitish hairs and with two rather obscure, transverse bands composed of dull, yellowish

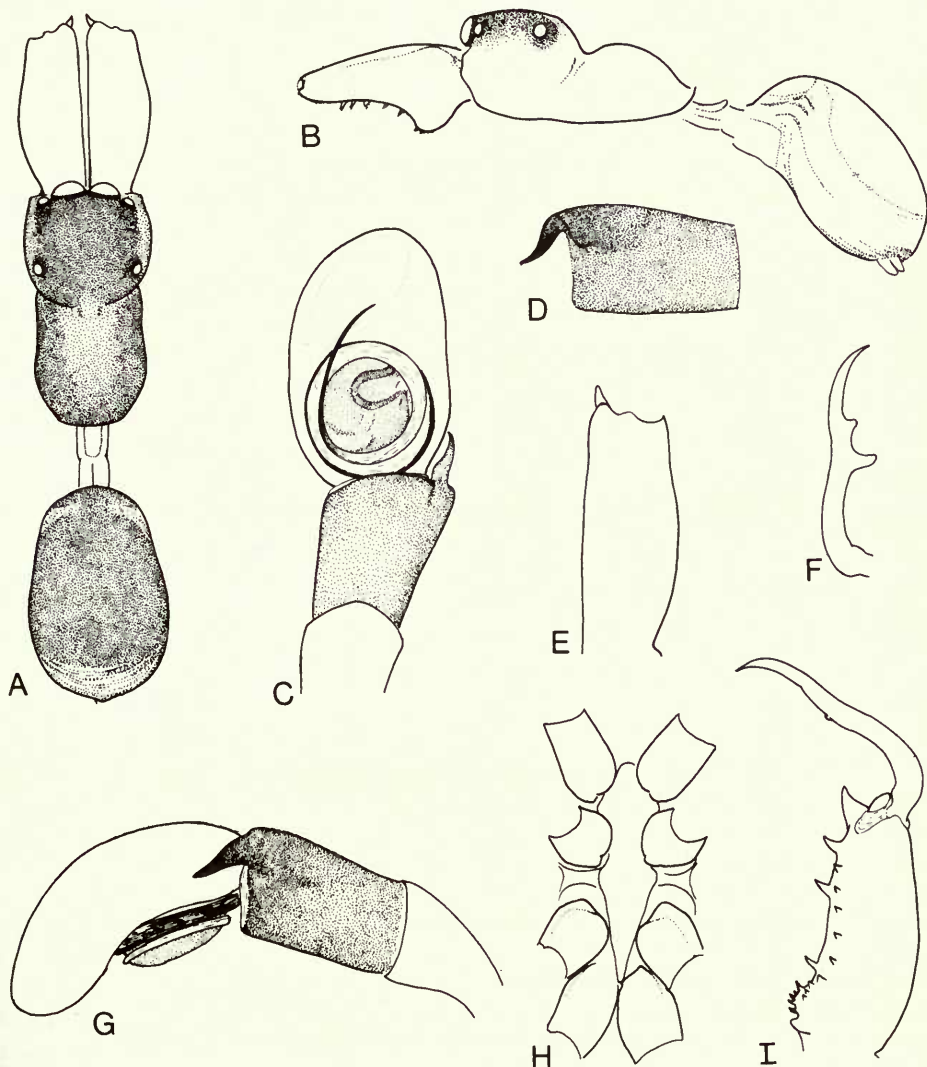

**Fig. 51** *Myrmarachne dundoensis* sp. n. Holotype ♂: (A) dorsal view; (B) lateral view; (C) palp, ventral view; (E) chelicera, dorsal view; (F) fang; (G) palp, lateral view; (H) sternum; (I) chelicera, ventral view. Paratype ♂: (D) palpal tibia showing flange and more sinuous apophysis.

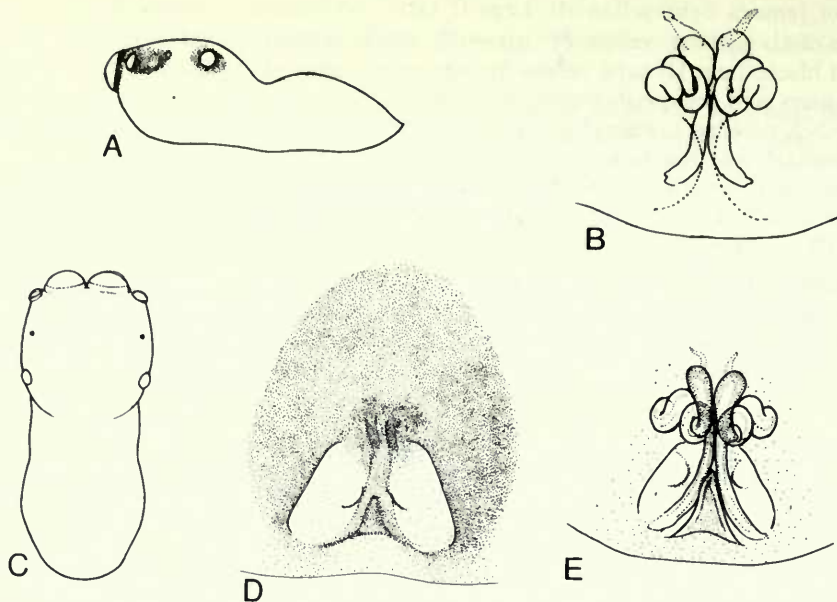

Fig. 52 *Myrmarachne dundoensis* sp. n. Paratype ♀: (A) carapace lateral view; (B) vulva, dorsal view; (C) carapace, dorsal view; (D) epigyne, ventral view; (E) vulva, ventral view.

lanceolate hairs. *Legs*: as in ♂ but coxae I and venter of trochanters I whitish yellow. *Epigyne* (Fig. 52B, D, E): spermathecae relatively complex.

*Dimensions*: total length 5.15–6.76 mm, carapace length 2.56–2.96 mm. *Ratios*: AM : AL : PM : PL: 9 : 4 : 1 : 4, AL-PM-PL: 7-7; a: 1.02-1.04, b: 1.02-1.04, c: 0.33-0.35, e: 0.92-1.02 (10♀ examined).

**BIOLOGY.** *M. dundoensis* has been found in association with *Camponotus* ants and I have collected both sexes from silk cells spun on blades of grass. Two cells contained females and eggs. One had 21 cream coloured eggs, all at an early stage of development; the second contained 4 eggs, 7 embryos and 13 first instar spiderlings. The eggs showed little sign of development and may have been sterile, but the embryos although still within the chorion were well advanced and probably about to hatch. The spiderlings were light yellow with blackish markings and pink eyes but the carapace and abdomen were not constricted. Some individuals were darker than others but none of them had moulted although there were plenty of spent chorions within the sac.

**DISTRIBUTION.** Angola, Botswana.

**MATERIAL EXAMINED.** Holotype ♂, ANGOLA, Dundo, swept from vegetation, 2.xi.1970 (*Local collector*, Ang. 22579.1) (MD, Dundo). Paratypes: ANGOLA: 1♂, data as for holotype; Dundo, swept from vegetation, 1♂, 4.x.1970 (*L. Carvalho*, Ang. 22479.1) (BMNH). BOTSWANA: Maun, dried out lagoon, nr Maphaneng Pan, 1♂, 3♀, 27.ii.1976 (*A. Russell-Smith & F. Wanless*); Maun, Thamalakane River, in grassland, 2♀, 2♂, 12.iii, 1♂, 17.iii, 1♂, 22.iii.1976 (*A. Russell-Smith & F. Wanless*); Moshi, Moshi bridge, flood plain grassland, 1♀ with eggs, 10.iii.1976 (*A. Russell-Smith & F. Wanless*); Manxunyane Lagoon, nr Maun, 2♀, 1♂, 4.iii, 1♂, 1♀, 1.iv.1976 (*A. Russell-Smith & F. Wanless*); Mboma Island, flood plain grassland, 1♀ with eggs, 14.iii.1976 (*A. Russell-Smith & F. Wanless*); Maphaneng Pan, nr Maun, 2♀, 1♂, 1.iv.1975 (*A. Russell-Smith*); Botletle River, about 10 miles S of Maun, sweeping in riverine woodland, 2♂, 5.iii.1976 (*A. Russell-Smith & F. Wanless*) (BMNH).

**ETYMOLOGY.** The specific name refers to the town in which the holotype was collected.



*Myrmarachne foreli* Lessert

(Fig. 53A-L)

*Myrmarachne foreli* Lessert, 1925b : 342, ♂. Holotype ♂, South Africa, Natal, Umbilo (NM, Pietermaritzburg) [Examined]. Roewer, 1954 : 942. Bonnet, 1957 : 3002. Roewer, 1965 : 69. Prószyński, 1971b : 437.

DIAGNOSIS. *M. foreli* is a distinctive species readily separated from other members of the *formicaria*-group by its body form (Fig. 53B, K). It is, however, reminiscent of *M. ichneumon* (Simon), which belongs to the *tristis*-group.

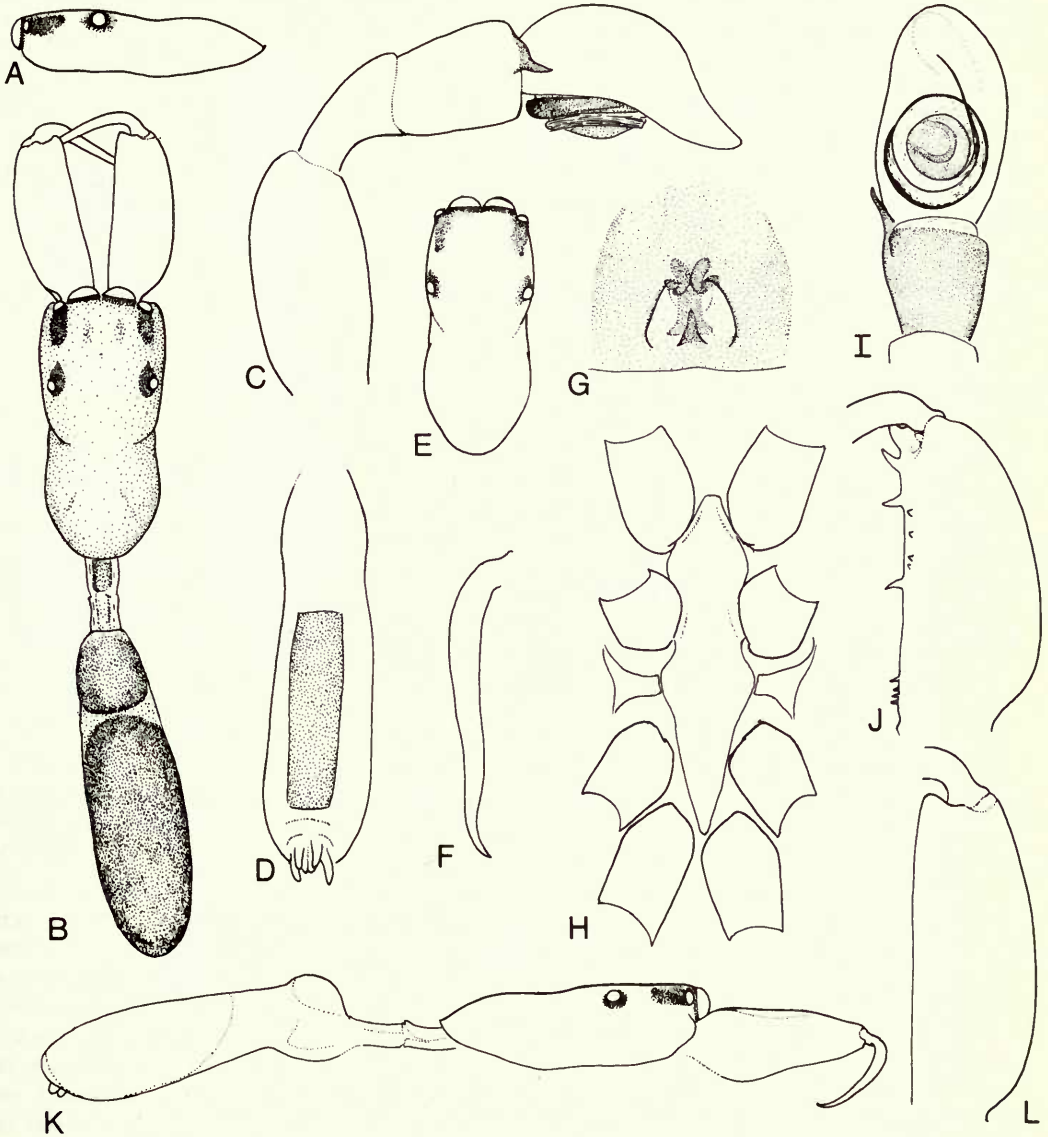

Fig. 53 *Myrmarachne foreli* Lessert. ♂: (B) dorsal view; (C) palp, lateral view; (D) abdomen, ventral view; (F) fang; (H) sternum; (I) palp, ventral view; (J) chelicera, ventral view; (K) lateral view; (L) chelicera, dorsal view. ♀: (A) carapace, lateral view; (E) carapace, dorsal view; (G) epigyne, ventral view.

MALE. *Carapace* (Fig. 53B, K): punctured-reticulate; orange-brown. *Eyes*: subcontiguous with apices procurved, sparsely fringed with white hairs. *Clypeus*: fringed with whitish hairs. *Chelicerae* (Fig. 53F, J, L): rugulose with furrows; orange-brown with metallic sheen; fang apophysis lacking. *Maxillae and Labium*: orange-brown. *Sternum* (Fig. 53H): orange-brown with darker margins. *Abdomen* (Fig. 53B, D, K): greyish with dorsal and ventral scuta mottled brownish black. *Legs*: femora I and IV enlarged; light orange-brown but tarsi and metatarsi I darker; ventral spination of legs I: metatarsi 2-2, tibiae 2-2-2-2, patellae 1. *Palp* (Fig. 53C, I): femora slightly enlarged.

*Dimensions*: total length 4.8-6.1 mm, carapace length 1.8-2.16 mm. *Ratios*: AM:AL:PM:PL: 7:3.5:1:3.5, AL-PM-PL: 6-6.5; a: 0.86-1.0, b: 0.95-1.0, c: 0.34-0.36, d: 0.47-0.62, e: 0.63-0.69 (7♂ examined).

FEMALE (formerly undescribed). *Carapace* (Fig. 53A, E): orange with yellowish guanin in eye region, shiny. *Eyes*: more or less as in ♂. *Clypeus*: as in ♂. *Chelicerae*: orange, shiny; promargin and retromargin with 6 teeth. *Maxillae and Labium*: as in ♂. *Sternum*: as in ♂. *Abdomen*: light greyish orange with posterior blackish; dorsal and ventral scuta lacking. *Legs*: more or less as in ♂. *Epigyne* (Fig. 53G): small and pale.

*Dimensions*: total length 5.48 mm, carapace length 1.84 mm. *Ratios*: AM:AL:PM:PL: 6:3:1:3.5, AL-PM-PL: 6-5; a: 1.02, b: 1.01, c: 0.36, e: 0.63 (1♀ examined).

Freshly preserved males are usually brown-black but become reddish to light orange with age. However, a ♂ from Angola and another from Botswana resemble the ♀ in colour by having whitish guanin within the eye region and the posterior half of the abdomen black.

BIOLOGY. Males are blackish in life and have been collected on at least two occasions with a sweep net. Their long, narrow bodies would appear to be well adapted to life in the field layer among grasses and reeds but their colour makes them conspicuous especially when they move up and down grass stems. Lessert (1925b) reports that *foreli* closely resembles *Tetraponera natalensis* (F. Smith).

DISTRIBUTION. Angola, Botswana, Malawi, South Africa.

MATERIAL EXAMINED. Type data given in synonymy. ANGOLA: Source of the Cuflo, Sa Tchisseke, 1♂, viii.1954 (*A. B. Machado*; Ang. 4375.4) (BMNH). BOTSWANA: Maun, Thamalakane River, grassland, field layer, 2♂, 2.iii.1976, 1♂, 12.iii.1976 (*A. Russell-Smith & F. Wanless*); Manxunyane Lagoon, nr Maun, flood plain grassland, field layer, 1♂, 1♀, 4.iii.1976 (*A. Russell-Smith & F. Wanless*) (BMNH). MALAWI: Chintheche, 1♀, i-ii.1976 (*R. Jocqué*, MT 147.918) (MRAC, Tervuren). SOUTH AFRICA: Pietermaritzburg, 1♂, 1913 (*C. Akerman*) (NM, Pietermaritzburg).

### *Myrmarachne uvira* sp. n.

(Fig. 54A-M)

DIAGNOSIS. *M. uvira* is closely related to *M. nigeriensis* sp. n. Males are distinguished by the lack of a fang apophysis and usually by the shape of the chelicerae (Fig. 54A, E). Females are best separated by the epigynes which have more complex spermathecae in this species (Fig. 54K-M).

MALE. *Carapace* (Fig. 54A, I): punctured-reticulate; brownish orange tinged with black, head darker with metallic sheen; sparsely covered with white pubescent hair with white wedge-shaped bands in constriction. *Eyes*: anteriors contiguous with apices procurved, fringed with white hairs. *Clypeus*: fringed with whitish hairs. *Chelicerae* (Fig. 54D-F): strongly rugulose with furrows; orange-brown with metallic sheen; fang apophysis lacking. *Maxillae and Labium*: yellow-brown tinged with black. *Sternum* (Fig. 54J): yellow-brown tinged with black. *Abdomen* (Fig. 54A, I): mottled yellow-brown and black with dark orange-brown scuta; clothed with white pubescent hair. *Legs*: legs I tarsi yellowish; metatarsi brown-black; remaining segments yellowish with black lateral streaks. Legs II similar to I but metatarsi yellowish. Legs III brown-black but tarsi and venter of patellae yellow-brown. Legs IV as III but trochanters and coxae whitish, the latter with blackish sides. Ventral spination of legs I: metatarsi 2-2, tibiae usually 2-2-2-2, patellae 1. *Palp* (Fig. 54C, G): tibial apophysis slender.

*Dimensions*: total length 3.6-5.12 mm, carapace length 1.6-2.16 mm. *Ratios*: AM:AL:

PM : PL : 6 : 3 : 1 : 3, AL-PM-PL : 5.5-5; a : 0.99-1.02, b : 1.0-1.02, c : 0.38-0.41, d : 0.49-0.62, e : 1.04-1.20 (10 ♂ examined).

FEMALE. *Carapace* (Fig. 54B, H): more or less as in ♂. *Eyes*: as in ♂. *Clypeus*: as in ♂. *Chelicerae*: rugulose with weak, proximal, prolateral keels; orange-brown, shiny; promargin with 6 teeth, retromargin with 5 or 6. *Maxillae and Labium*: as in ♂. *Sternum*: blackish, stippled with brownish orange. *Abdomen* (Fig. 54B): mottled brownish black with oblique whitish yellow bands laterally and obscure dorsal chevrons; sparsely covered with white pubescent hair. *Legs*: more or less as in ♂ but tibiae I with 2-2-2-2 spines. *Epigyne* (Fig. 54K-M).

*Dimensions*: total length 4.12-5.16 mm, carapace length 1.64-2.16 mm. *Ratios*: AM : AL : PM : PL : 7 : 4 : 1.5 : 4, AL-PM-PL : 6-6; a : 1.02, b : 1.02, c : 0.37-0.39, e : 0.98-1.0 (10 ♀ examined).

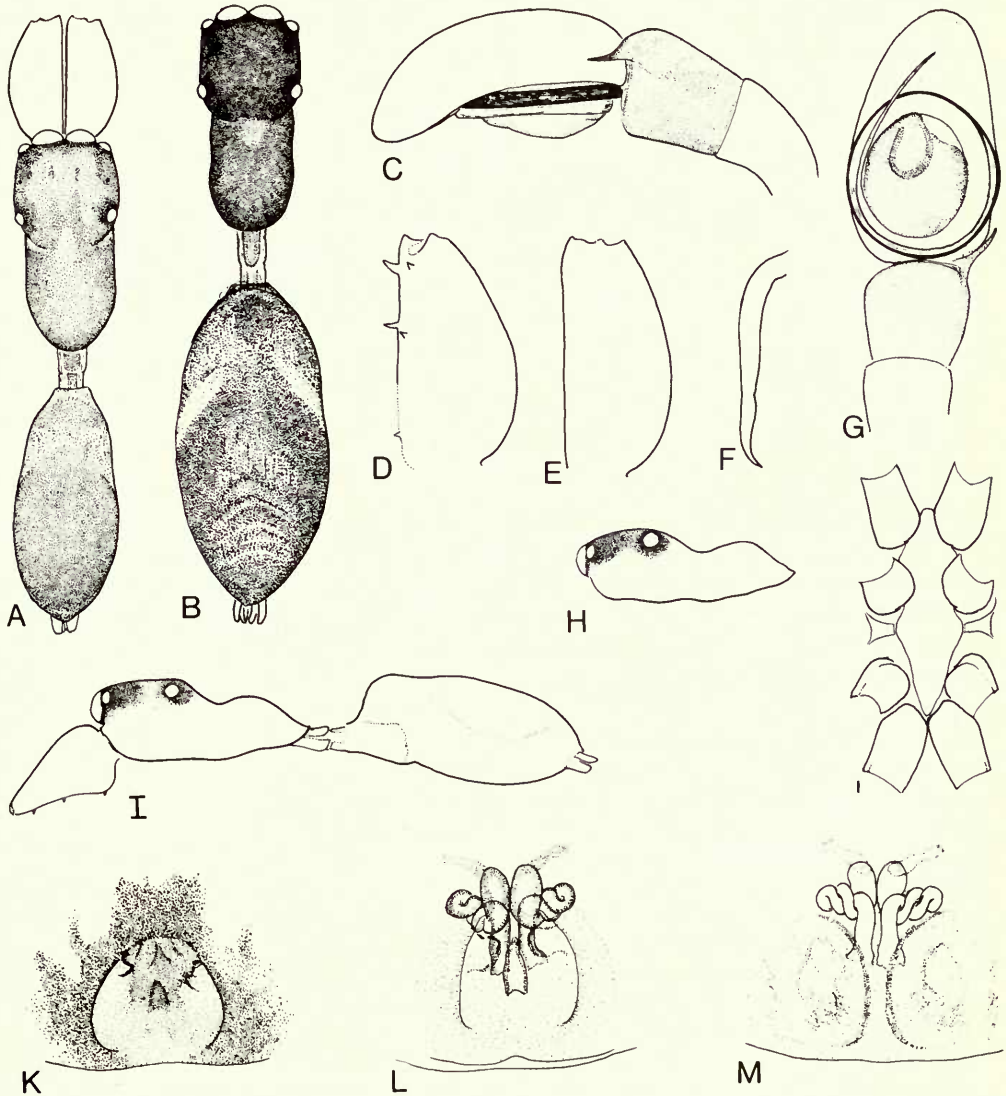

Fig. 54 *Myrmarachne uvira* sp. n. Holotype ♂: (A) dorsal view; (C) palp, lateral view; (D) chelicera, ventral view; (E) chelicera, dorsal view; (F) fang; (G) palp, ventral view; (I) lateral view; (J) sternum. Paratype ♀: (B) dorsal view; (H) carapace, lateral view; (K) epigyne, ventral view; (L) vulva, ventral view; (M) vulva, dorsal view.



**BIOLOGY.** *M. wira* is an active species whose quick, jerky movements and waving front legs are very ant-like. At rest, the ant-like stance is maintained with the body held well above the ground but the tip of the abdomen almost touching and gently undulating from side to side. In courtship (seen once in captivity) the ♂ approaches the ♀ poised on three pairs of legs, with the first pair stretched outwards at an angle of about 45° but with the tarsi and metatarsi pointing down. In this pose he runs about after the ♀ frequently approaching with a side-stepping motion. The ♀ which was not receptive, refused the ♂ by either running away or indulging in vigorous palp tapping when at rest, but occasionally adopting an aggressive posture by facing the ♂ with legs I raised (F. Wanless, unpublished observations). *M. wira* is believed to mimic *Camponotus sericeus* (Fab.) in Ghana (see Material examined).

**DISTRIBUTION.** Botswana, Ghana, Kenya, Tanzania, Zaire.

**MATERIAL EXAMINED.** Holotype ♂, ZAIRE, Uvira, in hymenopteran nest, 7.ix.1959 (*G. Marlier*, MT 116276) (MRAC, Tervuren). Paratypes: BOTSWANA: Maun, Thamalakane River, grassland, 6♂, 1♀, iv-i.1975/76 (*A. Russell-Smith*); 12♂, 8♀, iii.1976 (*A. Russell-Smith & F. Wanless*); Island Safari Lodge, nr Maun, riverine forest, 2♀, 21.ix.1975 (*A. Russell-Smith*); Borro River, Dandridge House, nr Maun, flood plain grassland, ground layer, 1♀, 29.iii.1976 (*A. Russell-Smith & F. Wanless*); Maun, dried out lagoon, nr Maphaneng Pan, 6♂, 4♀, 27.ii.1976 (*A. Russell-Smith & F. Wanless*); Manxunyane Lagoon, nr Maun, 1♀, 1.iv.1976 (*A. Russell-Smith & F. Wanless*) (BMNH). GHANA: Nungua, 1♂, 25.v.1973 (*M. Edmunds*, vial 28) with *Camponotus sericeus* (BMNH). KENYA: Kilifi, swept from low bushes and shrubs in a hot dry sandy garden, 2♂, 1♀, 11.vii.1974 (*J. & F. Murphy*, vial 4050) (BMNH). TANZANIA: Kigoma, by railway track, 1♀, 1♂, 11.x.1959 (*J. A. L. Cooke*, 2nd Oxford Univ. Expd.) (BMNH). ZAIRE: Congo da Lemba, 1♂, 1917 (*R. Mayne*, MT 130772) (MRAC, Tervuren).

**ETYMOLOGY.** The specific name is a noun in apposition taken from the region where the holotype was collected.

### *Myrmarachne nigeriensis* sp. n.

(Figs 55A–J; 56A–M)

**DIAGNOSIS.** *M. nigeriensis* is closely related to *M. wira* sp. n. Males can be distinguished by the form of the chelicerae (Figs 55A, B; 56A, D, E) which are somewhat broader proximally, and by the presence of the fang apophysis. Females are separated by the epigyne (Fig. 56I, K, L) which is characterized in this species by a single loop in the proximal duct.

**MALE.** *Carapace* (Fig. 55A, B, G, I): punctured-reticulate; black with white wedge-shaped bands in constriction. *Eyes*: anteriors more or less contiguous with apices procurved, fringed with white hairs. *Clypeus*: sparsely fringed with white hairs. *Chelicerae* (Fig. 56A, C–H): rugulose with furrows, a strong metallic sheen under some lights; brown-orange suffused with black with black lateral keels; fang apophysis present. *Maxillae and Labium*: blackish with inner margins of maxillae and labial tip light orange. *Sternum* (Fig. 56J): blackish. *Abdomen* (Fig. 55A, B, G, I): black with poorly defined brown-black scuta; sparsely clothed with light brown hairs; anterior spinnerets black, rest dark brown. *Legs*: slender; legs I tarsi pale yellow-brown; metatarsi light brown tinged with black; tibiae and patellae light brown streaked with black; trochanters and coxae blackish, the former with yellowish venter. Legs II as I but metatarsi light brown; trochanters and coxae yellowish with black sides. Legs III tarsi light brown; metatarsi and tibiae light brown with blackish sides; other segments black-brown but venter of patellae yellowish. Legs IV as III but sides of tibiae blackish. Ventral spination of legs I: metatarsi 2–2, tibiae 2–2–2–2, patellae 1. *Palp* (Fig. 55D, E, H, J).

*Dimensions*: total length 3.3–4.76 mm, carapace length 1.58–1.96 mm. *Ratios*: AM : AL : PM : PL : 8 : 5 : 1.3 : 4.5, AL–PM–PL: 7.5–4.8; a: 1.02–1.04, b: 1.02–1.08, c: 0.42–0.44, d: 0.35–0.45, e: 0.85–0.95 (8♂ examined).

**FEMALE.** *Carapace* (Fig. 55C, F): orange-brown suffused with black. *Eyes*: more or less as in ♂. *Clypeus*: as in ♂. *Chelicerae*: rugulose with weak proximal prolateral keels; orange, shiny; fang

groove with 5 or 6 promarginal teeth and 8–10 retromarginal *Maxillae and Labium*: orange tinged with black. *Sternum*: orange-brown mottled with black. *Abdomen* (Fig. 55C): yellow-brown mottled and tinged with black with obscure chevrons posteriorly; posterior spinnerets black, others yellow-brown. *Legs*: colour as in ♂ but femora I with black streaks inside only and coxae I with venter yellowish. Ventral spination of legs I as in ♂ but metatarsi with 2–2–2–2–2 or 2–2–2–2–1–2 spines. *Epigyne* (Fig. 56I, K, L).

*Dimensions*: total length 4.0–5.84 mm, carapace length 1.84–2.12 mm. *Ratios*: AM : AL : PM : PL: 9 : 5 : 1.3 : 5, AL–PM–PL: 7.5–5.5; a: 1.02–1.04, b: 1.04–1.07, c: 0.41–0.44, e: 0.89–1.0 (4♀ examined).

An orange-coloured ♂ from Angola (Fig. 55B, E) has different palps with the embolus appearing to be somewhat heavier and larger. The specimen could represent a new taxon but the differences are considered to be intraspecific until additional material is available from which to make a comparison.

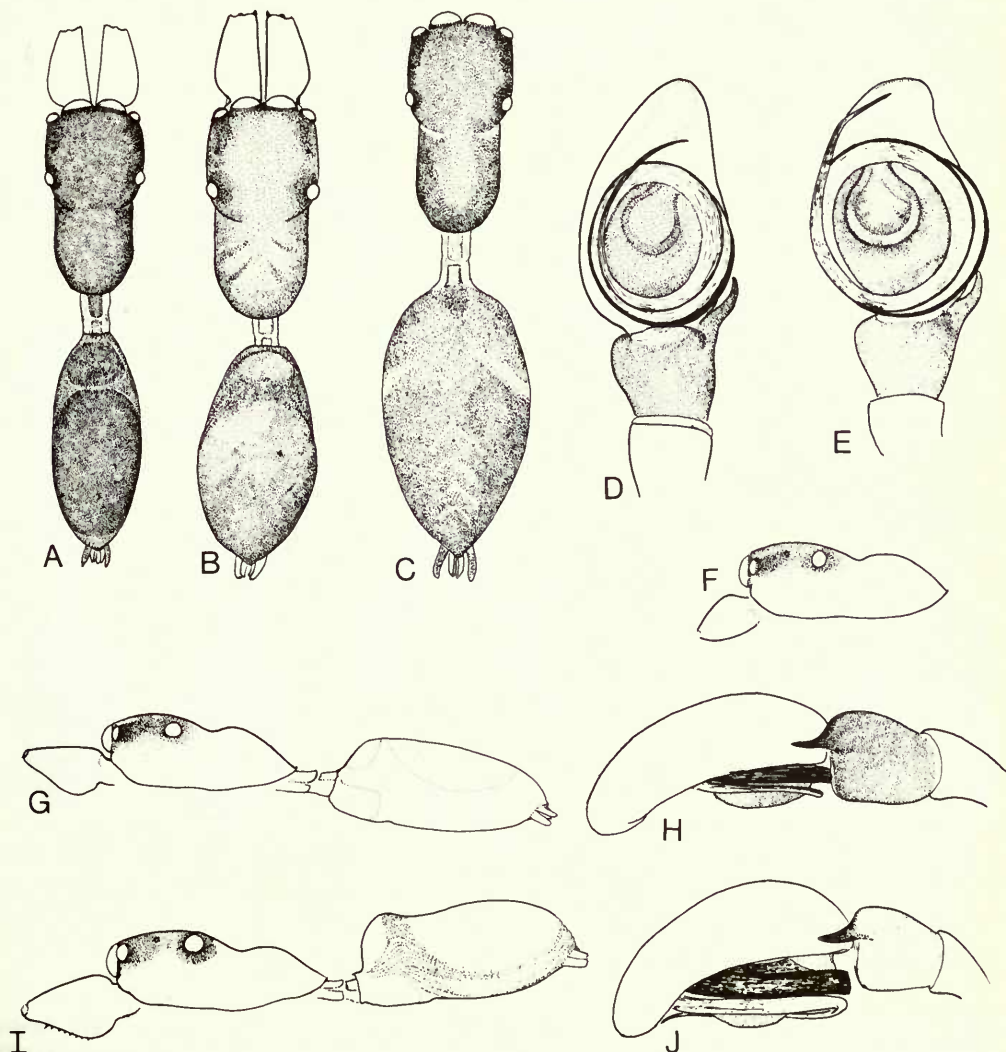

Fig. 55 *Myrmarachne nigeriensis* sp. n. Holotype ♂: (A) dorsal view; (D) palp, ventral view; (G) lateral view; (H) palp, lateral view. ♂ from Angola: (B) dorsal view; (E) palp, ventral view; (I) lateral view; (J) palp, lateral view. Paratype ♀: (C) dorsal view; (F) carapace, lateral view.



BIOLOGY. Unknown but Nigerian specimens have been found running about with *Camponotus* ants (A. Russell-Smith, pers. comm.).

DISTRIBUTION. Angola, Ghana, Nigeria, São Thomé.

MATERIAL EXAMINED. Holotype ♂, NIGERIA, Ibadan, International Institute for Tropical Agriculture, Centre for Overseas Pest Research site, 18.iii.1974 (A. Russell-Smith) (BMNH, reg. no. 1975.11.25.1). Paratypes. ANGOLA: between Lubango and Hoque, under fallen trees, 1♂, 27.x.1949 (A. B. Machado, Ang. 4030) (BMNH). GHANA: Kade, pyrethrum knockdown sample from the canopy of a plot of Amelonado cocoa, 1♂, 26.i.1972, 1♂, 2♀, 13.vii.1971 (J. D. Majer) (BMNH). NIGERIA: 3♂ same data as holotype; Ibadan, 2♀, 8.viii.1973 (A. Russell-Smith) (BMNH). SÃO THOMÉ: 1♂ (MNHN, Paris).

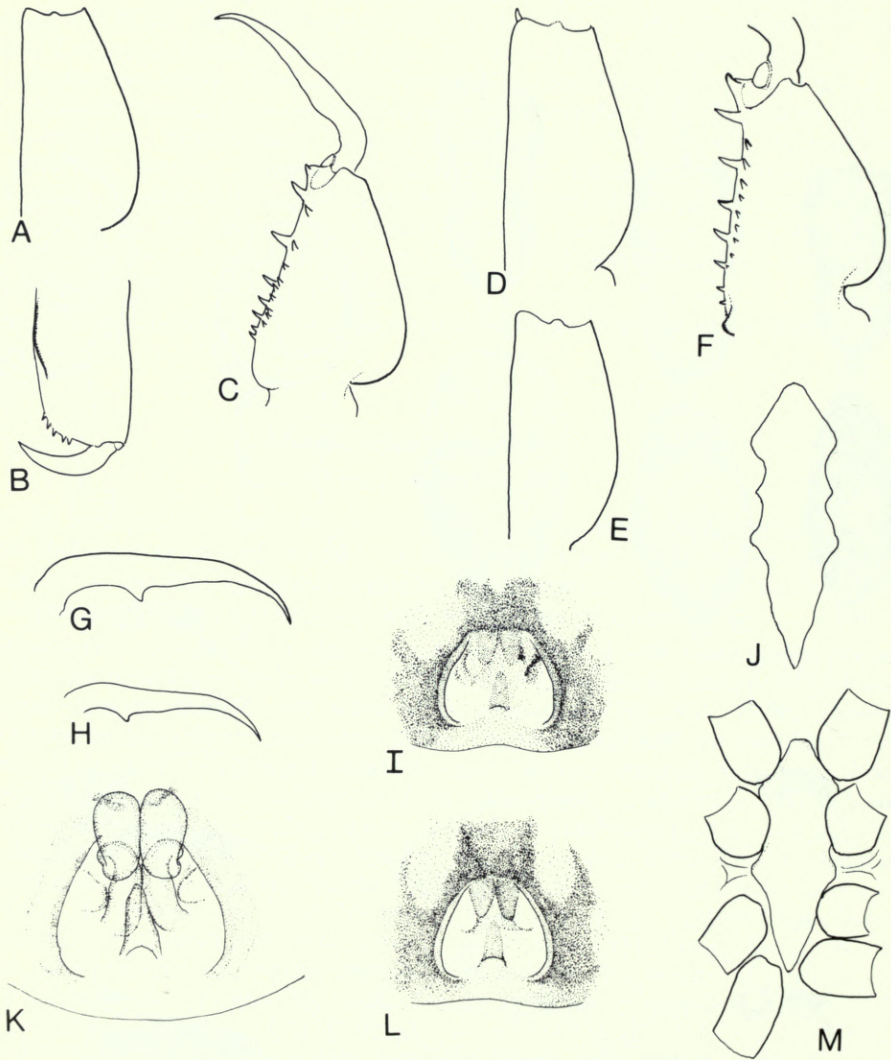

Fig. 56 *Myrmarachne nigeriensis* sp. n. Holotype ♂: (A) chelicera, dorsal view; (B) chelicera, ventral view; (C) fang; (D) sternum. ♂ from Angola: (D) chelicera, dorsal view; (F) chelicera, ventral view; (G) fang; (H) sternum. ♂ from São Thomé, (E) chelicera, dorsal view. Paratype ♀: (B) chelicera, frontal view; (I) epigyne, ventral view; (K) vulva, ventral view; (L) epigyne, ventral view of another specimen from Ibadan.



*Myrmarachne vanessae* sp. n.

(Fig. 57A-L)

**DIAGNOSIS.** *M. vanessae* is a distinctive species readily separated from other members of the *formicaria*-group by the shape of the carapace (Fig. 57A, F, G, K) and unusual markings on the carapace and sternum. In body form it closely resembles *M. richardsi* sp. n., a distinctive species in the *tristis*-group.

**MALE.** *Carapace* (Fig. 57F, K): punctured-reticulate in eye region with small rounded depression on each side of thoracic part; brown with blackish mottling; head slightly darker with a metallic sheen; constriction light yellow-brown and shiny under some lights. *Eyes*: AM subcontiguous, slightly further from AL with apices procurved, fringed with whitish hairs. *Clypeus*: sparsely fringed with long light brown hairs. *Chelicerae* (Fig. 57H-I): rugulose with furrows; orange

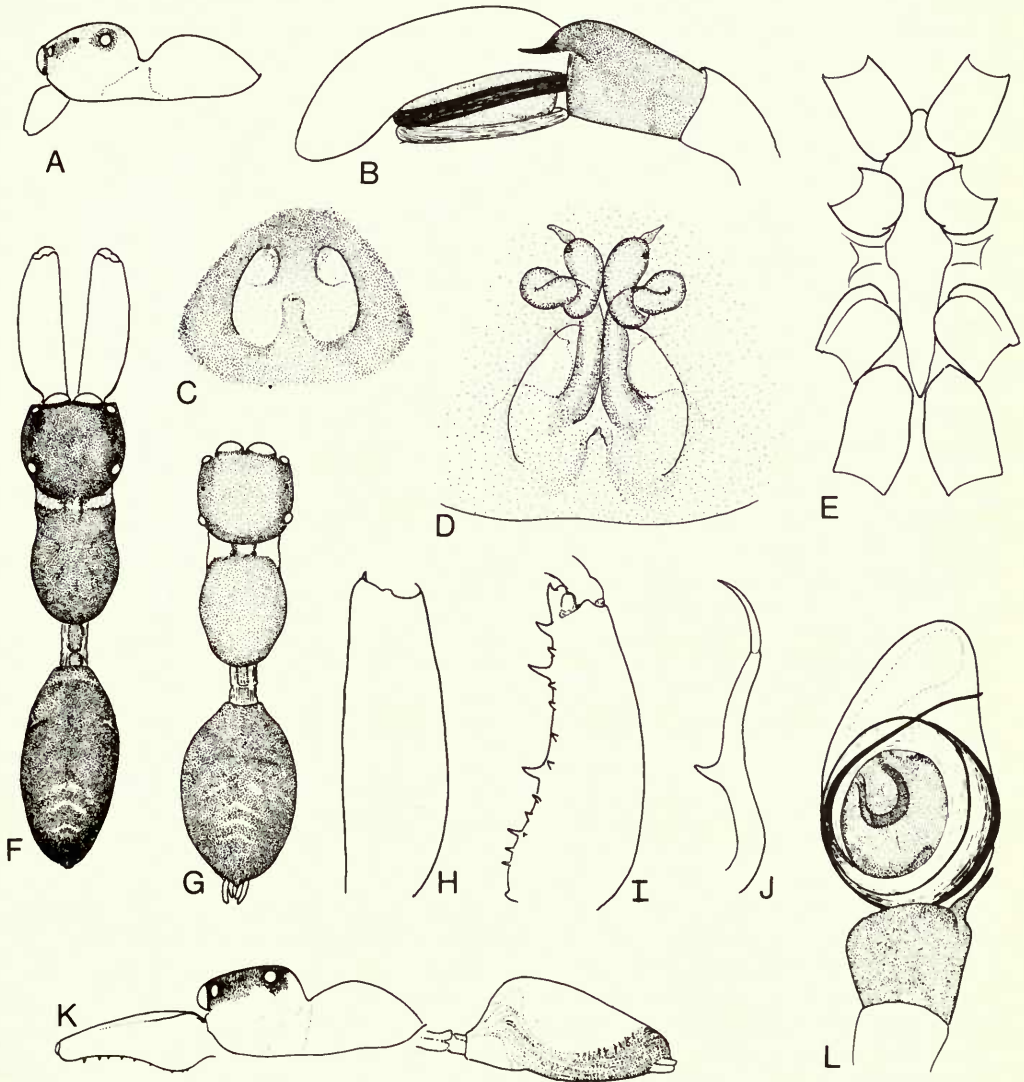

**Fig. 57** *Myrmarachne vanessae* sp. n. Holotype ♂: (B) palp, lateral view; (E) sternum; (F) dorsal view; (H) chelicera, dorsal view; (I) chelicera, ventral view; (J) fang; (K) lateral view; (L) palp, ventral view. Paratype ♀: (A) carapace, lateral view; (C) epigyne ventral view; (D) vulvae, ventral view; (G) dorsal view.

with blackish mottling; fang apophysis present. *Maxillae and Labium*: blackish with inner margins of maxillae and labial tip yellow-brown. *Sternum* (Fig. 57E): anterior half yellow, posterior half black, margins orange-brown. *Abdomen* (Fig. 57F, K): blackish with contiguous scuta that are shiny dark mahogany with obscure chevrons posteriorly; sparsely clothed with fine hairs. *Legs*: slender; legs I tarsi and metatarsi orange-brown suffused with black; tibiae and patellae yellow-brown with black stripe on inner sides; coxae and trochanters blackish. Legs II as I but tarsi and metatarsi yellow-brown. Legs III brown suffused with black but tarsi, metatarsi distally and venter of patellae light yellow-brown. Legs IV brownish black with distal segments lighter; trochanters whitish yellow, with yellowish marks on patellae. Ventral spination of legs I: metatarsi 2-2-2, tibiae 2-2-2-2, patellae 0. *Palp* (Fig. 57B, L).

*Dimensions*: total length 5.2 mm, carapace length 2.56 mm. *Ratios*: AM : AL : PM : PL: 9 : 4.2 : 1 : 4.7, AL-PM-PL: 6-6; a: 0.99, b: 1.0, c: 0.33, d: 0.62, e: 0.96 (1 ♂ examined).

FEMALE. *Carapace* (Fig. 57A, G): olivaceous, suffused with black; constriction glistening whitish yellow with two blackish stripes enclosing a white spot mid-dorsally. *Eyes*: more or less as in ♂ but fringed with brownish hairs. *Clypeus*: fringed with long white and pale brown hairs. *Chelicerae*: rugulose; shiny, whitish yellow; fang groove with 6 retromarginal teeth (promarginal teeth not examined). *Sternum*: whitish yellow with posterior half olivaceous, suffused with black. *Abdomen* (Fig. 57G): shiny, olivaceous suffused with black with ill-defined chevrons posteriorly; sparsely covered with fine hairs, with a vague transverse line of minute greenish iridescent lanceolate hairs in region of constriction. *Legs*: slender; legs I whitish yellow with black streaks along inside of tarsi, metatarsi, tibiae and patellae and on both sides of femora. Legs II whitish yellow with black streak along inside of tibiae, patellae and distal half of femora. Legs III olivaceous suffused with black with tarsi, metatarsi distally and venter of patellae whitish. Legs IV coxae, femora, tibiae and metatarsi olivaceous, tinged with black, the last two segments lighter distally; trochanters whitish with black distal spot inside; patellae whitish with dorsal distal part black; tarsi whitish with black sides. Ventral spination of legs I as in ♂. *Epigyne* (Fig. 57C, D).

*Dimensions*: total length 5.1 mm, carapace length 2.48 mm. *Ratios*: AM : AL : PM : PL: 9 : 4 : 1.2 : 4.5, AL-PM-PL: 6-6, a: 1.01, b: 1.03, c: 0.33, e: 0.87 (1 ♀ examined).

BIOLOGY. Unknown.

DISTRIBUTION. Ivory Coast.

MATERIAL EXAMINED. Holotype ♂, IVORY COAST, nr Bandama, Lamto Field Station, 20.ix.1967 (*J. Jezequel*) (MNHN, Paris). Paratype. 1 ♀, same data as holotype.

ETYMOLOGY. This species is named after my youngest daughter Vanessa Wanless.

### *Myrmarachne russellsmithi* sp. n.

(Fig. 58A-H)

DIAGNOSIS. *M. russellsmithi* is closely related to *M. kitale* sp. n., and *M. inflatipalpis* sp. n. but may be distinguished by the form of the carapace (Fig. 58A, B) and palp structure (Fig. 58C, E).

FEMALE. Unknown.

MALE. *Carapace* (Fig. 58A, B): finely rugulose in eye region; orange-brown lightly mottled with black, glossy. *Eyes*: anteriors subcontiguous with apices procurved, fringed with white hairs. *Clypeus*: sparsely fringed with long fine hairs. *Chelicerae* (Fig. 58D, F, G): finely rugulose; yellow-brown with black lateral keels, glossy; fang apophysis present, also a distinct distal swelling. *Maxillae*: yellow-brown tinged with black. *Labium*: orange-brown. *Sternum* (Fig. 58H): orange-brown with blackish stippling, glossy. *Abdomen* (Fig. 58A, B): mottled brownish black with glossy, dark mahogany scuta. *Legs*: glossy under some lights; legs I tarsi and metatarsi brownish black; other segments light yellowish with blackish lateral streaks. Legs II light yellow-brown with black streaks on inside of tibiae and patellae and on both sides of femora. Legs III brown tinged with black but tarsi and distal half of metatarsi paler. Legs IV as III but venter of patellae white and coxae and trochanters white with blackish markings. Ventral spination of legs I: metatarsi 2-2, tibiae 2-2-1; patellae 0. *Palp* (Fig. 58C, E): tegulum very small.



*Dimensions*: total length 3.10 mm, carapace length 1.54 mm. *Ratios*: AM : AL : PM : PL : 6 : 3 : 1 : 3, AL-PM-PL : 4.5-6; a : 0.90, b : 1.0, c : 0.41, d : 0.46, e : 0.84 (1 ♂ examined).

*BIOLOGY*. Unknown but the only known specimen was clearly found away from its natural habitat, as it probably lives in the field and shrub layers where it presumably mimics *Crematogaster* ants.

*DISTRIBUTION*. Nigeria.

*MATERIAL EXAMINED*. Holotype ♂, NIGERIA, Ibadan, International Institute for Tropical Agriculture, Building 400, 3.iv.1973 (A. Russell-Smith), found on concrete roadway surrounded by closely mowed grass lawns (BMNH, reg. no. 1975.1.31.10).

*ETYMOLOGY*. This species is named in honour of the collector Mr A. Russell-Smith.

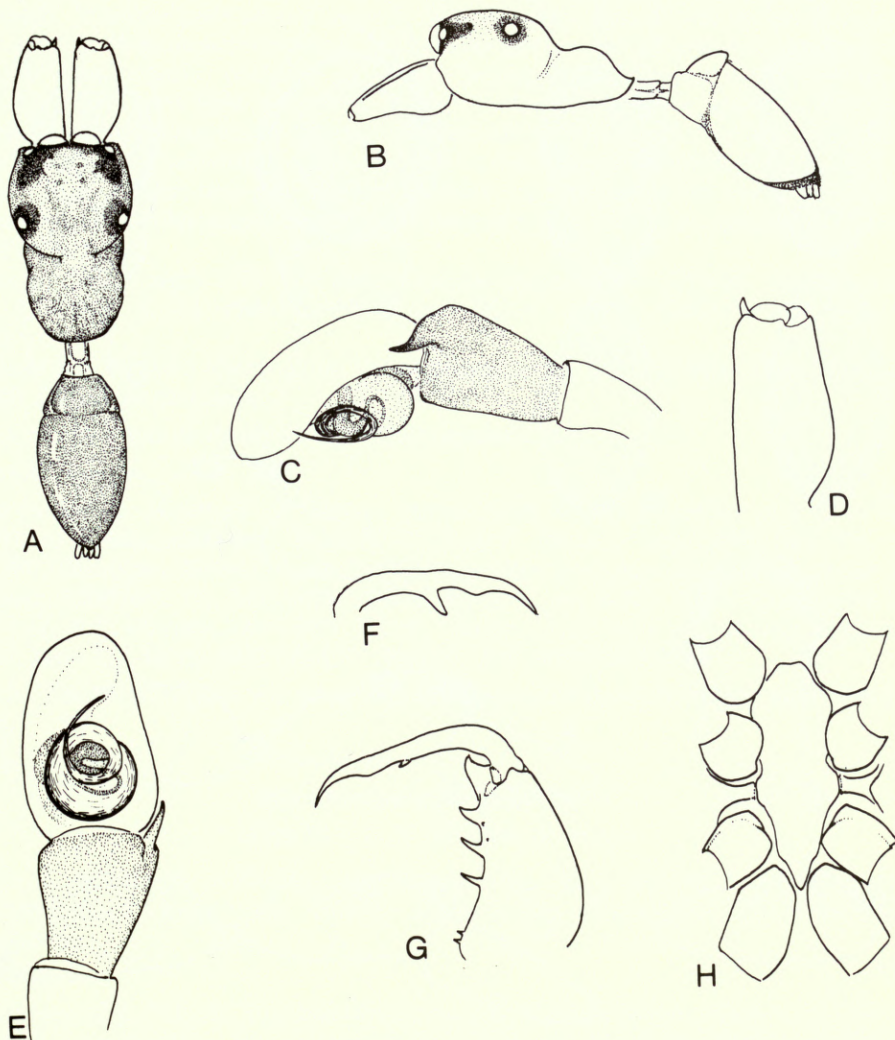

**Fig. 58** *Myrmarachne russellsmithi* sp. n. Holotype ♂: (A) dorsal view; (B) lateral view; (C) palp, lateral view; (D) chelicera, dorsal view; (E) palp, ventral view; (F) fang; (G) chelicera, ventral view; (H) sternum.



*Myrmarachne kitale* sp. n.

(Figs 59B, D, E, H, I; 60B, D, H-M)

DIAGNOSIS. *M. kitale* is closely related to *M. russellsmithi* sp. n. and *M. inflatipalpis* sp. n. but may be distinguished by the carapace shape (Fig. 59H, I) and palp structure (Figs 59D; 60B) which is somewhat intermediate between that of *russellsmithi* and *inflatipalpis*. Females can be distinguished from other females in the *formicaria*-group by the carapace shape (Fig. 59E, H) and epigyne structure (Fig. 60K-M).

MALE. *Carapace* (Fig. 59B, I): punctured-reticulate in eye region; orange-brown tinged with black; shiny, with white wedge-shaped bands in constriction which is outlined by darker edges dorsally. *Eyes*: more or less contiguous with apices procurved, fringed with fine hairs. *Clypeus*:

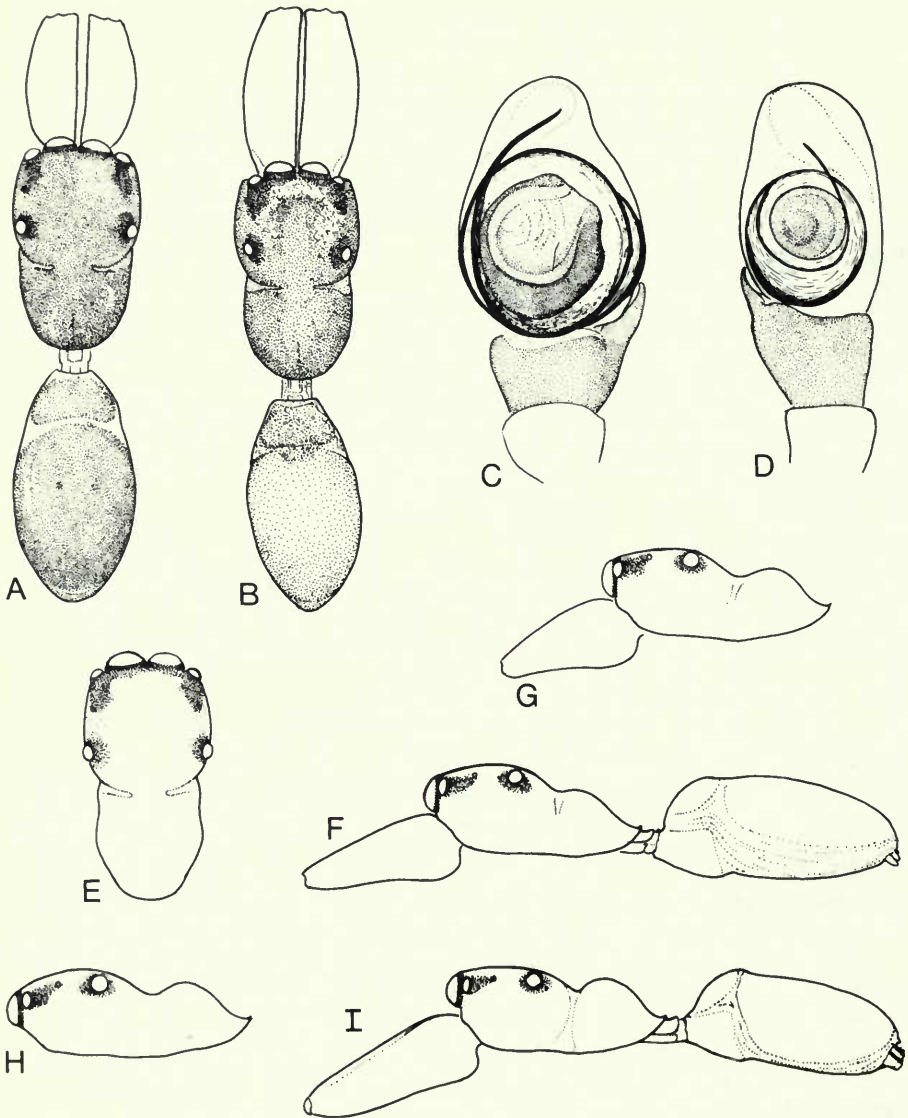

Fig. 59 (A, C, F, G) *Myrmarachne inflatipalpis* sp. n. Holotype ♂: (A) dorsal view; (C) palp, ventral view; (F) lateral view. ♂ from Botswana: (G) carapace, lateral view. (B, D, E, H, I) *Myrmarachne kitale* sp. n. Holotype ♂: (B) dorsal view; (D) palp, ventral view; (I) lateral view. Paratype ♀: (E) carapace, dorsal view; (H) carapace, lateral view.

fringed with fine hairs. *Chelicerae* (Fig. 60D, H, 1): rugulose with furrows; orange-brown, shiny; fang apophysis present. *Maxillae and Labium*: orange-brown tinged with blackish with inner margins of maxillae and labial tip lighter. *Sternum* (Fig. 60J): orange-brown tinged with black. *Abdomen* (Fig. 59B, 1): light yellow-brown with blackish mottling and glossy orange-brown scuta. *Legs*: legs I tarsi yellow-brown; metatarsi blackish; tibiae and patellae light yellow-brown with blackish lateral streaks; femora dark brownish orange; trochanters and coxae light yellowish, the former with blackish sides. Legs II similar to I but metatarsi and femora light yellow, the latter with dark brown sides. Legs III dark orange-brown with metatarsi distally, tibiae distally and venter of patellae yellow-brown. Legs IV as III but trochanters and coxae marked with whitish yellow. Ventral spination of legs I: metatarsi 2-2, tibiae 2-2, patellae 0. *Palp* (Figs 59D; 60B).

*Dimensions*: total length 4.54 mm, carapace length 1.78 mm. *Ratios*: AM : AL : PM : PL : 6 : 3 : 1 : 3, AL-PM-PL: 4.5-6; a: 0.89, b: 0.93, c: 0.40, d: 0.78, e: 0.69 (1 ♂ examined).

**FEMALE.** *Carapace* (Fig. 59E, H): similar to ♂ but orange. *Eyes*: more or less as in ♂. *Clypeus*: as in ♂. *Chelicerae*: rugulose; light orange, shiny; fang groove with 7 promarginal and 6 retro-marginal teeth. *Maxillae and Labium*: as in ♂. *Sternum*: light orange with darker margins, shiny. *Abdomen*: greyish white tinged with pink, with darker poorly defined anterior scutum and 2 pairs of impressed dots dorsally; posterior spinnerets brown-black, anteriors light brown, medians whitish. *Legs*: legs I tarsi light yellowish; metatarsi black; remaining segments light yellowish but with black streaks along inside of tibiae, patellae and trochanters and on both sides of femora and coxae. Legs II light yellowish with inner black streaks except on metatarsi and tarsi. Legs III orange with tibiae darker, tarsi and metatarsi lighter. Legs IV as III but venter of patellae, trochanters and coxae whitish yellow. Ventral spination of legs I: as in ♂ but tibiae 2-2-2, patellae 1. *Epigyne* (Fig. 60K-M).

*Dimensions*: total length 3.76-4.54 mm, carapace length 1.68-1.78 mm. *Ratios*: AM : AL : PM : PL : 7 : 3.5 : 1 : 4, AL-PM-PL: 5.5-6; a: 1.02, b: 1.02, c: 0.40-0.41, e: 0.69-0.71 (4 ♀ examined).

One female has blackish chevrons on the abdomen, while another from Naro Moru is much darker with a blackish abdomen.

**BIOLOGY.** Unknown but probably mimics *Crematogaster* ants.

**DISTRIBUTION.** Kenya.

**MATERIAL EXAMINED.** Holotype ♂, KENYA, beaten from shrubs in garden of a farm about 20 miles north of Kitale, 6500 feet, 20.vii.1974 (*J. & F. Murphy*, vial 3599) (BMNH, reg. no. 1977.4.21.34). Paratypes. KENYA: Lake Naivasha, beaten from Kei apple hedge about 35 yards from the lake, 6200 feet, 2 ♀, 3.vii.1974 (*J. & F. Murphy*, vial 3888); Naro Moro, 6500 feet, 1 ♀, 17.viii.1974 (*J. & F. Murphy*, vial 4245); Kitale, Copper Dam, from cell on reed at edge of small fresh water dam, 1 ♀, 16.viii.1972 (*J. & F. Murphy*, vial 1950) (BMNH).

**ETYMOLOGY.** The specific name is a noun in apposition taken from the region where the holotype was found.

*Myrmarachne inflatipalpis* sp. n.

(Figs 59A, C, F, G; 60A, C, E-G)

**DIAGNOSIS.** *M. inflatipalpis* is closely related to *M. kitale* sp. n. and *M. russellsmithi* sp. n. but may be distinguished by the rather bulbous tegulum (Fig. 60A) and its correspondingly large seminal reservoir.

**FEMALE.** Unknown.

**MALE.** *Carapace* (Fig. 59A, G, F): punctured-reticulate; orange-brown, shiny with white wedge-shaped bands in constriction. *Eyes*: anteriors subcontiguous with apices procurved, fringed with white hairs. *Clypeus*: sparsely fringed with long, fine hairs. *Chelicerae* (Fig. 60C, F, G): rugulose with furrows; orange-brown with blackish lateral keels, shiny; fang apophysis present. *Maxillae and Labium*: light orange-brown with inner distal margins of maxillae and labial tip lighter.



*Sternum* (Fig. 60E): orange with darker margins. *Abdomen* (Fig. 59A, F): mottled yellow-brown and black with glossy brownish orange scuta separated by a scanty white haired band. *Legs*: femora I slightly enlarged. Legs I tarsi, trochanters and coxae yellow-brown; metatarsi blackish; tibiae and patellae yellow-brown with darker sides; femora brown. Legs II generally yellow-brown with darker sides except on tarsi and metatarsi. Legs III brown tinged with black but tarsi and metatarsi distally yellow-brown. Legs IV as III but venter of patellae, trochanters and coxae light yellow. Ventral spination of legs I: metatarsi 2-2, tibiae 2-2-2, patellae 1. *Palp* (Figs 59C; 60A): tegulum rather bulbous ventrally.

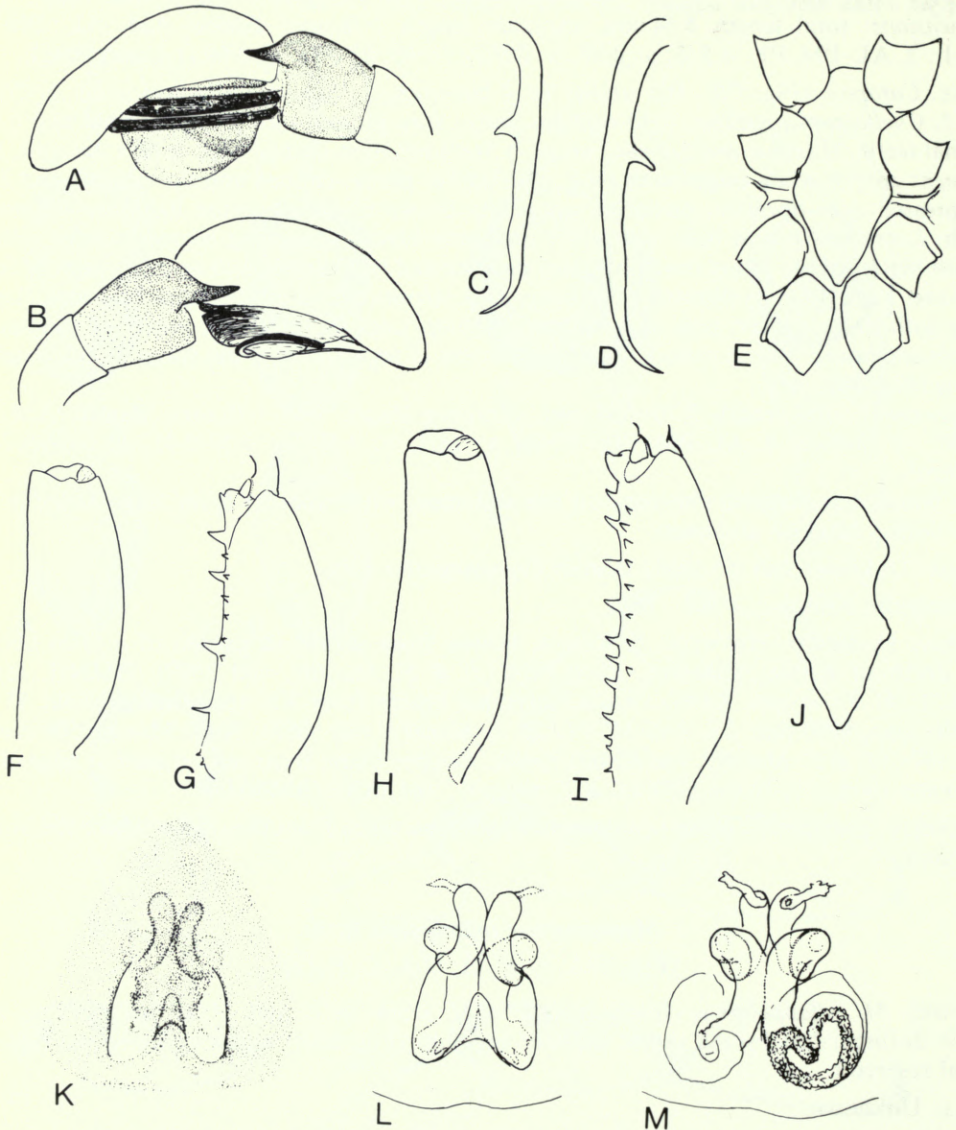

**Fig. 60** (A, C, E-G) *Myrmarachne inflatipalpis* sp. n. Holotype ♂: (A) palp, lateral view; (C) fang; (E) sternum; (F) chelicera, dorsal view; (G) chelicera, ventral view. (B, D, H-M) *Myrmarachne kitale* sp. n. Holotype ♂: (B) palp, lateral view; (D) fang; (H) chelicera, dorsal view; (I) chelicera, ventral view; (J) sternum. Paratype ♀: (K) epigyne, ventral view; (L) vulva, ventral view; (M) vulva, dorsal view.



*Dimensions*: total length 3.08–4.2 mm, carapace length 1.42–1.96 mm. *Ratios*: AM : AL : PM : PL : 7 : 3.5 : 1 : 3.5, AL–PM–PL : 5–5.3; a : 0.86–1.0, b : 0.92–1.0, c : 0.38–0.42, d : 0.57–0.80, e : 0.66–0.75 (6♂ examined).

Freshly preserved specimens vary from orange to dark brown and some individuals appear to be more glossy than others. The carapace shows differences in shape (Fig. 59G) with the thoracic part forming a more distinct 'hump' in some individuals.

**BIOLOGY.** *M. inflatipalpis* has been found running about on shrubs with a species of *Crematogaster* ant whose appearance and behaviour it closely mimics. In life both ant and spider are reddish with shiny black pointed 'abdomens' that are held in a reflexed position when disturbed. The movements of the spider are ant-like and there is no doubt that it mimics both the gait and defensive behaviour of the ant although unlike the ant it does not have a defensive secretion.

**DISTRIBUTION.** Botswana, Malawi, South Africa.

**MATERIAL EXAMINED.** Holotype ♂, SOUTH AFRICA, Transvaal, Pietersburg District, Letaba Basin from the river bank, ix.1960 (*N. Leleup*, MT 132199) (MRAC, Tervuren). Paratypes. BOTSWANA: Kgwebe Hills, ground layer, 1♂, 31.iii.1976 (*A. Russell-Smith & F. Wanless*); nr Gadikwee Lagoon, 1♂, 16.x.1975 (*A. Russell-Smith*) (BMNH). MALAWI: Zomba, 1♂, x.1961 (*R. C. H. Sweeney*) (BMNH). SOUTH AFRICA: Pretoria, 1♂ (MNHN, Paris); Pietermaritzburg, 1 Fettes Road, on garden lawn, 1♂, 18.iv.1976 (*A. Russell-Smith & F. Wanless*) (NM, Pietermaritzburg); Magaliesburg, Magalies R., on shrubs by river bank, 6 subadults, 11.iv.1976 (*G. Newlands, A. Russell-Smith & F. Wanless*) (BMNH). Pondoland, Port St Johns, 1♂, iv.1923 (*R. E. Turner*) (BMHN).

**ETYMOLOGY.** The specific name refers to the swollen palp of the male.

### The *volatilis*-group

Species of *Myrmarachne* belonging here may be recognized by the following combination of characters. Males: lower distal margin of fang groove lobate (Fig. 64C, D); tibial apophysis more or less sinuous; flange lacking (Fig. 63I, J); proximal ectal margin of cymbium not de-

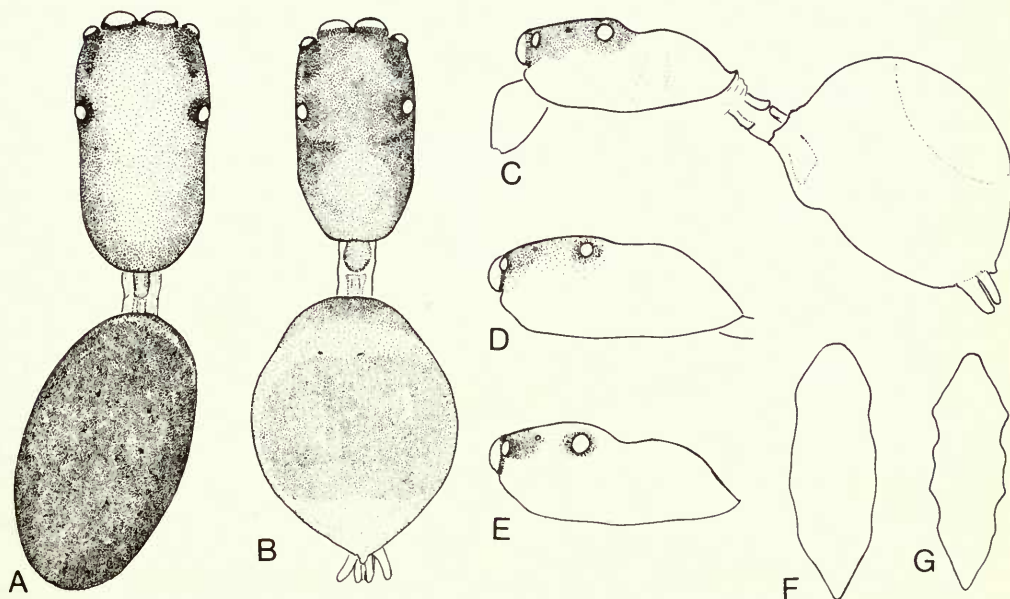

**Fig. 61** (A, D, E, F) *Myrmarachne volatilis* (Peckham & Peckham). Lectotype ♀: (A) dorsal view; (D) carapace, lateral view; (F) sternum. ♀ from Est Antsirabe: (E) carapace, lateral view. (B, C, G) *Myrmarachne globosa* sp. n. Holotype ♀: (B) dorsal view; (C) lateral view; (G) sternum.

pressed or protuberant; seminal reservoir large and marginate (Fig. 63B). Females: median subtriangular pouch present; spermathecae simple, without loops or twists (Fig. 62).

This group is comprised of 6 species in the Ethiopian region, 2 from Madagascar and 4 from Africa, but it is also known to occur in the Oriental and Australasian regions.

The Ethiopian species show a wide variation in body form and can, for convenience, be divided into two subgroups. The first contains four closely related species, *M. volatilis* (Peckham & Peckham), *M. globosa* sp. n., *M. kilifi* sp. n. and *M. laurentina* Bacelar, that are characterized by a rather heavy carapace, shallow postocular constriction and very similar genitalia. The second subgroup includes two slender species, *M. andrewi* sp. n. and *M. longiventris* (Simon), that are not closely related but are characterized by their elongate body form and low, unconstricted carapace.

Sexual dimorphism is perhaps slightly less marked in the *volatilis*-group as males have relatively short chelicerae that are inclined at about 45° in *M. andrewi* and in several undescribed species from Borneo and Australia. Its affinities are uncertain but similarities with *Belippo* are spurious,

### *Myrmarachne volatilis* (Peckham & Peckham)

(Figs 61A, D, E, F; 62A–C)

*Hermosa volatilis* Peckham & Peckham, 1892 : 53, pl. 4, figs 7, 7a, 7b, 7c, ♀. LECTOTYPE ♀ (here designated), Madagascar (MCZ, Harvard) [Examined].

*Myrmarachne majungae* Strand, 1907 : 745, ♀. Holotype ♀, Madagascar, Majunga (MNHU, Berlin) [Examined]. Roewer, 1954 : 943; 1965 : 66. **Syn. n.**

*Myrmarachne majungana*: Bonnet, 1957 : 3009. Prószyński, 1971b : 439. [Unjustified emendation.]

*Myrmarachne volatilis*: Roewer, 1954 : 944. Bonnet, 1957 : 3014. Roewer, 1965 : 64.

DIAGNOSIS. *M. volatilis* is closely related to *M. laurentina* from South Africa but may be distinguished by the sausage-shaped spermathecae (Fig. 62A–C).

MALE. Unknown.

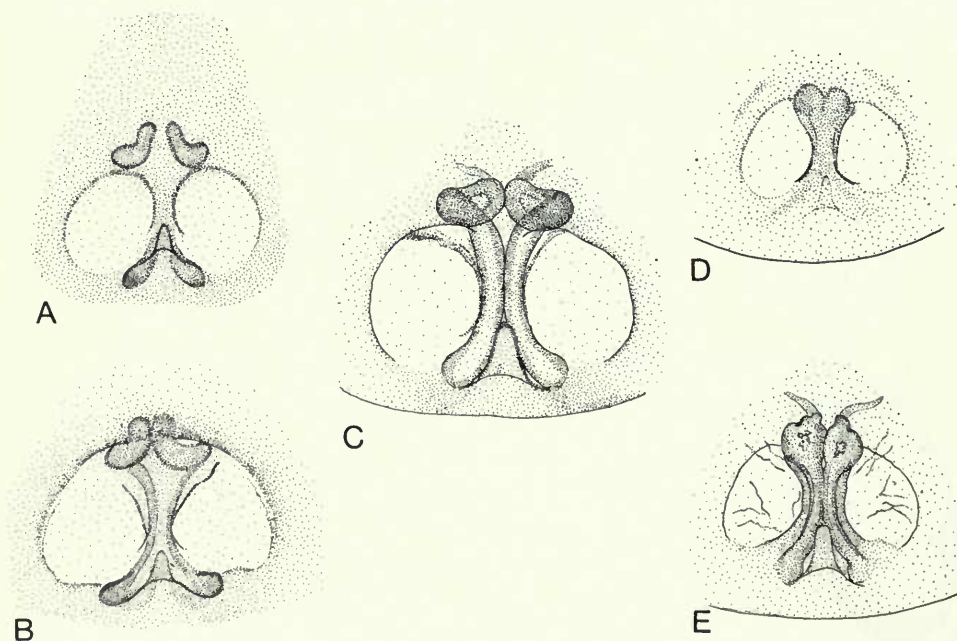

Fig. 62 (A–C) *Myrmarachne volatilis* (Peckham & Peckham). Lectotype ♀: (B) epigyne, ventral view. Paralectotype ♀: (A) epigyne, ventral view. ♀ from Est Antsirabe: (C) vulva, ventral view. (D, E) *Myrmarachne globosa* sp. n. Holotype ♀: (D) epigyne, ventral view; (E) vulva, ventral view.

FEMALE. *Carapace* (Fig. 61A, E): punctured-reticulate with papillae on thoracic part; orange-brown or brown-black with scattered long white hairs. *Eyes*: anteriors subcontiguous with apices slightly procurved, fringed with white hairs. *Clypeus*: fringed with long white hairs. *Chelicerae*: robust; rugulose with furrows; orange-brown; promargin with 7 or 8 teeth, retromargin with 8 or 9. *Maxillae and Labium*: brown with inner margins of maxillae and labial tip paler. *Sternum* (Fig. 61F): light brown. *Abdomen* (Fig. 61A): mottled brownish orange and black with 2 pairs of impressed spots dorsally. *Legs*: legs I tarsi and metatarsi dark orange-brown; tibiae and patellae yellow-orange with brownish orange sides; femora orange-brown with venter light yellowish distally; trochanters brownish orange; coxae light yellowish. Legs II as I but tarsi, metatarsi and coxae orange-brown. Legs III orange-brown. Legs IV as III but trochanters and patellae marked with yellowish. Ventral spination of legs I: metatarsi 2-2; tibiae 2-2-2-2, patellae 0. *Epigyne* (Fig. 62A-C): position of spermathecae and pouch slightly variable.

*Dimensions*: total length 5.1-7.1 mm, carapace length 2.12 mm. *Ratios*: AM : AL : PM : PL : 10.5 : 5 : 1 : 5, AL-PM-PL: 9-11; a: 0.93-1.02, b: 1.0-1.02, c: 0.39-0.44, e: 0.74-0.90 (4♀ examined).

A large female from Est Antsirabe has a deeper postocular constriction (Fig. 61E) with poorly defined chevrons on the abdomen.

BIOLOGY. Unknown.

DISTRIBUTION. Madagascar.

MATERIAL EXAMINED. Type data given in synonymy. MADAGASCAR: Est Antsirabe, 1♀, 10.xi.1970 (*J. Gossuin*, MT 142531) (MRAC, Tervuren). Tamatave, 1♀ (MNHN, Paris).

*Myrmarachne globosa* sp. n.

(Figs 61B, C, G; 62D, E; Pl. 3a, b)

DIAGNOSIS. *M. globosa* is closely related to *M. volatilis* Peckham & Peckham and *M. laurentina* Bacelar but can be readily distinguished by the form of sculpturing in the eye region (i.e. punctured-reticulate between moderately dense piliferous papillae, Pl. 3a, b).

MALE. Unknown.

FEMALE. *Carapace* (Fig. 61B, C; Pl. 3a, b): punctured-reticulate between moderately dense piliferous papillae in eye region and punctured reticulate with papillae in thoracic part; orange to light orange with white pubescent hair. *Eyes*: anteriors subcontiguous with apices slightly procurved, fringed with white hairs. *Clypeus*: fringed with white and light brown hairs. *Chelicerae*: rugulose; orange; promargin with 6 teeth, retromargin with 14. *Maxillae and Labium*: light orange. *Sternum* (Fig. 61G): light orange with darker margins. *Abdomen* (Fig. 61B, C); rubbed and probably full of eggs; whitish yellow with poorly defined light orange scutum. *Legs*: orange to whitish orange. Ventral spination of legs I: metatarsi 2-2; tibiae 2-2-2-2-2-1 or 2-2-2-2-2-2, patellae 0. *Epigyne* (Fig. 62D, E).

*Dimensions*: total length 7.2-7.84 mm, carapace length 3.24-3.36 mm. *Ratios*: AM : AL : PM : PL : 13 : 7 : 2 : 7, AL-PM-PL: 10-9.5, a: 1.03, b: 1.01, c: 0.41-0.42, e: 1.06-1.13 (2♀ examined).

BIOLOGY. Unknown.

DISTRIBUTION. Angola, Zaire.

MATERIAL EXAMINED. Holotype ♀, ANGOLA, environs of Dundo, in litter 10-13.x.1946 (*A. B. Machado*, Ang. 71.6) (MD, Dundo). Paratype. ZAIRE: Rwankur, 1♀, 15.ii.1952 (*J. V. Leroy*, MT 78965) (MRAC, Tervuren).

ETYMOLOGY. The specific name refers to the form of the spermathecae.

*Myrmarachne laurentina* Bacelar

(Figs 63A, B, E, G, I; 64B, C; 65A-C, G, H)

*Myrmarachne laurentina* Bacelar, 1953 : 8, figs 4-8, ♂. Holotype ♂, Mozambique, Lourenço Marques (MB, Lisbon) [Examined].



DIAGNOSIS. Female *M. laurentina* are distinguished from female *M. volatilis* (Peckham & Peckham) and *M. kilifi* sp. n. by the rounded spermathecae (Fig. 65G, H) and from *M. globosa* sp. n. by the lack of piliferous papillae in the eye region. The absence of a dorsal spike on the tibial apophysis (Fig. 63I) separates male *laurentina* from a male *kilifi*. Male *volatilis* and *globosa* are unknown.

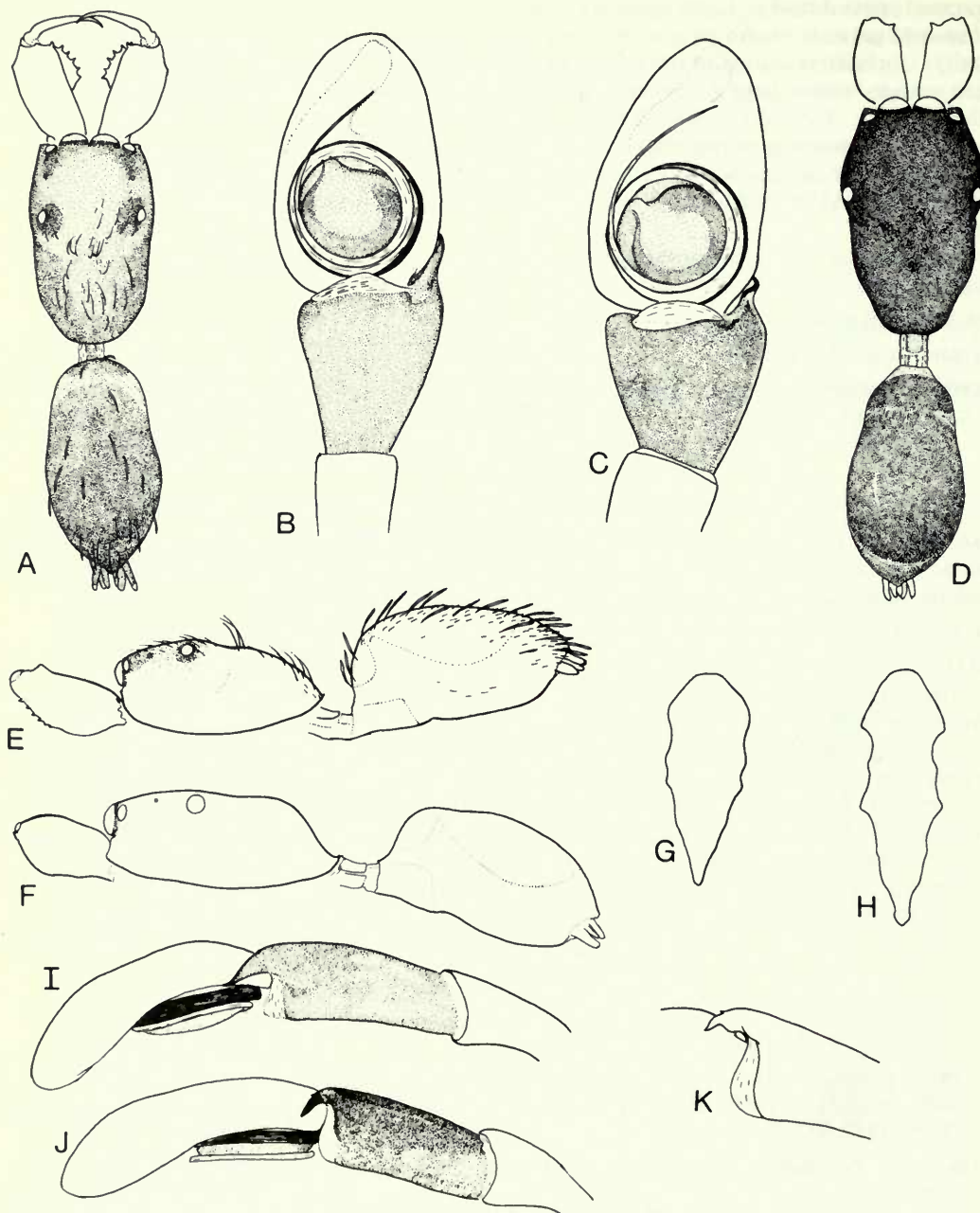

Fig. 63 (A, B, E, G, I) *Myrmarachne laurentina* Bacelar, ♂ from South Africa: (A) dorsal view; (B) palp, ventral view; (E) lateral view; (G) sternum; (I) palp, lateral view. (C, D, F, H, J, K) *Myrmarachne kilifi* sp. n. Holotype ♂: (C) palp, ventral view; (D) dorsal view; (F) lateral view; (H) sternum; (J) palp, lateral view; (K) palpal tibia showing minute dorsal spike on apophysis.

MALE. *Carapace* (Fig. 63A, E): punctured-reticulate with scattered punctures in eye region to papillate with scattered punctures on thoracic part; dark orange with short white simple hairs and long, white lanceolate ones. *Eyes*: anteriors subcontiguous with apices more or less level, fringed with white hairs. *Clypeus*: white haired. *Chelicerae* (Fig. 64B, C): rugulose with retro-lateral and distal, prolateral spurs; orange-brown with black lateral keels; fang apophysis lacking. *Maxillae and Labium*: light brownish, labium darker with very slight median keel. *Sternum* (Fig. 63G) yellow-brown suffused with blackish. *Abdomen* (Fig. 63A, E): mottled brownish black with orange-brown scuta; clothed with short, simple and long, lanceolate hairs. *Legs*: legs: femora, trochanters and coxae of legs I enlarged. Legs I tarsi and metatarsi light orange-brown tinged with black; tibiae and patellae yellow-brown with blackish lateral stripes; trochanters and femora orange-brown the latter with yellowish sides distally; coxae whitish yellow. Legs II light yellow-brown to pale orange-brown tinged with grey, with greyish lateral stripes on tibiae and patellae. Legs III light orange-brown tinged with grey. Legs IV as III but trochanters whitish yellow. Ventral spination of legs I: metatarsi 2-2, tibiae 2-2-2, patellae 0. *Palp* (Fig. 63B, I).

*Dimensions*: total length 4.64-6.8 mm, carapace length 2.16-3.24 mm. *Ratios*: AM : AL : PM : PL: 11:5 : 6 : 2 : 6, AL-PM-PL: 9-12; a: 0.88-0.91, b: 0.88-1.0, c: 0.40-0.42, d: 0.33-0.51, e: 0.87-0.97 (3♂ examined).

FEMALE (formerly undescribed). *Carapace* (Fig. 65A, B): similar to ♂; dark reddish with scattered short white hairs and long, rather stout ones. *Eyes*: anteriors subcontiguous with apices procurved, fringed with whitish hairs. *Clypeus*: fringed with long light brown hairs. *Chelicerae*: rugulose; orange; promargin with 5 teeth retromargin with 7. *Maxillae and Labium*: orange-brown, labium darker with light tip. *Sternum*: pale orange with darker margins. *Abdomen* (Fig. 65A): yellow-brown mottled with black, a golden tinge posteriorly; scuta reddish orange with velvet sheen and 2 pairs of impressed dots dorsally; sparsely covered with long white hairs. *Legs*: femora slightly enlarged. Legs I tarsi and metatarsi orange tinged with black; tibiae and patellae light yellow-brown with grey lateral streaks; femora dark orange with sides and venter light yellow-brown distally; trochanters and coxae pale yellowish. Legs II tarsi and metatarsi light yellow-brown; tibiae and patellae light yellowish with greyish lateral streaks; femora and trochanters whitish yellow; coxae orange-brown. Legs III orange-brown with tarsi and metatarsi distally lighter. Legs IV orange-brown but trochanters and patellae marked with whitish. Ventral spination of legs I: as in ♂ but tibiae with 2-2-2-2 spines. *Epigyne* (Fig. 65G, H).

*Dimensions*: total length 6.96 mm, carapace length 2.84 mm. *Ratios*: AM : AL : PM : PL: 11 : 5 : 1 : 5.5, AL-PM-PL: 9-11; 1: 1.02, b: 1.0, c: 0.42, e: 0.87 (1♀ examined).

BIOLOGY. Unknown.

DISTRIBUTION. Mozambique, South Africa.

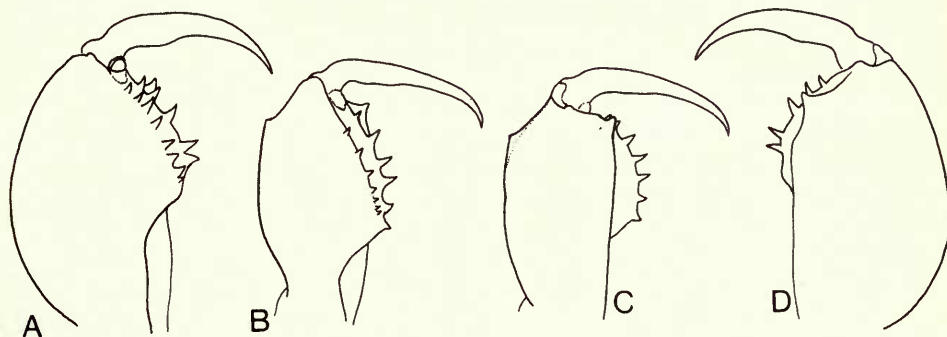

Fig. 64 (A, D) *Myrmarachne kilifi* sp. n. ♂ chelicera: (A) ventral view; (D) dorsal view. (B, C) *Myrmarachne laurentina* Bacelar ♂ chelicera: (B) ventral view; (C) dorsal view.

MATERIAL EXAMINED. Holotype ♂, data given in synonymy. SOUTH AFRICA: East London, 1♂ (*C. Martin*) (MNHN, Paris); Natal, 1♂, 1♀ (*C. Martin*) (MNHN, Paris).

REMARKS. The long, stout white hairs on this species could be useful diagnostic characters. However, their absence in other species of the *volatilis*-group needs to be confirmed as most individuals available at the present time have been rubbed to a greater or lesser degree.

*Myrmarachne kilifi* sp. n.

(Fig. 63C, D, F, H, J, K: 64A, D; 65D-F, I, J; Pl. 3c, d)

DIAGNOSIS. *Myrmarachne kilifi* closely resembles *M. laurentina* but can be distinguished by the presence of a dorsal spike on the tibial apophysis (Fig. 63J, K) and inverted, drop-like spermathecae (Fig. 65I, J).

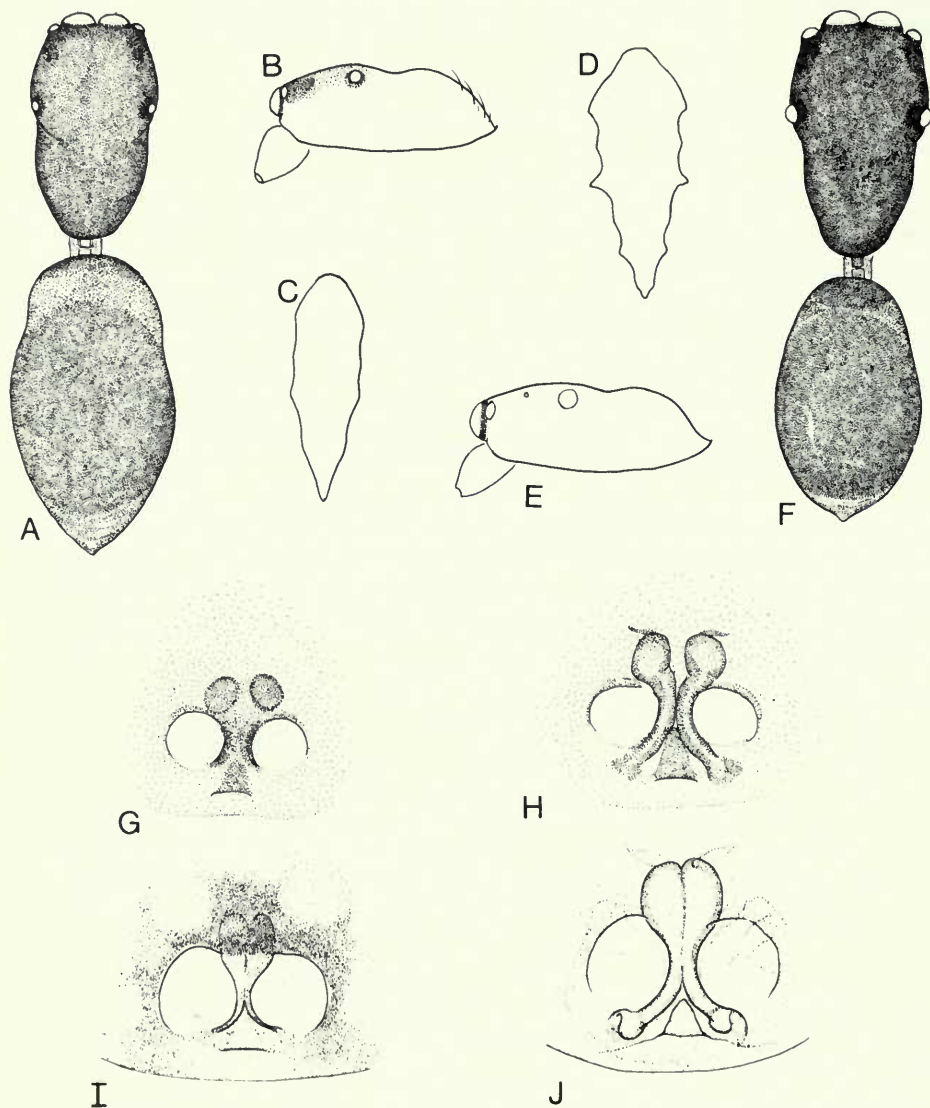

Fig. 65 (A-C, G, H) *Myrmarachne laurentina* Bacelar. ♀ from South Africa: (A) dorsal view; (B) carapace, lateral view; (C) sternum; (G) epigyne, ventral view; (H) vulva, ventral view. (D-F, I, J) *Myrmarachne kilifi* sp. n. Paratype ♀: (D) sternum; (E) carapace, lateral view; (F) dorsal view; (I) epigyne, ventral view; (J) vulva, ventral view.



MALE. *Carapace* (Fig. 63D, F): eye region punctured-reticulate with scattered punctures to longitudinally papillate between PL with thoracic part densely papillate; black with a metallic sheen, with scattered short white lanceolate hairs on thoracic 'hump' and upper part of constriction. *Eyes*: anteriors subcontiguous with apices slightly procurved, fringed with whitish hairs. *Clypeus*: sparsely white haired. *Chelicerae* (Fig. 64A, D): rugulose with a distal, prolateral spur; brownish orange tinged with black, glossy under some lights with blackish lateral keels; fang apophysis lacking but a swelling proximally. *Maxillae*: brownish orange tinged with black. *Labium*: dark brownish with a very slight median keel. *Sternum* (Fig. 63H): light yellowish tinged with black, margins darker. *Abdomen* (Fig. 63D, F): mottled yellow-black; scuta dark brownish orange suffused with black; thinly covered with fine hairs with scattered white lanceolate hairs in constriction. *Legs*: legs I with femora, trochanters and coxae enlarged; distal segments yellow-brown with blackish lateral streaks; femora yellow-brown suffused with black; trochanters and coxae light yellowish. Legs II light yellow-brown with blackish lateral streaks on tibiae, patellae and femora; trochanters and coxae whitish yellow. Legs III light brown suffused with black, the distal segments darker. Legs IV as III but trochanters and patellae marked with whitish yellow. Ventral spination of legs I: metatarsi 2-2, tibiae 1-2-2-2-1-1-2, patellae 0. *Palp* (Fig. 63C, J, K).

*Dimensions*: total length 6.56 mm, carapace length 3.08 mm. *Ratios*: AM : AL : PM : PL : 12 : 6 : 1.5 : 7, AL-PM-PL: 10-10; a: 0.98, b: 1.0, c: 0.42, d: 0.41, e: 0.87 (1 ♂ examined).

FEMALE. *Carapace* (Fig. 65E, F; Pl. 3c, d): similar to ♂ but longitudinal papillae more distinct. *Eyes*: subcontiguous with apices procurved, fringed with white hairs. *Clypeus*: as in ♂. *Chelicerae*: rugulose; brownish orange with inner distal margins lighter; promargin with 3 teeth, retro-margin with 6. *Maxillae and Labium*: similar to ♂ but keel entirely lacking. *Sternum* (Fig. 65D). *Abdomen* (Fig. 65F): mottled yellow-black; scuta dark brownish orange suffused with black; thinly clothed with fine hairs with white lanceolate hairs in constriction. *Legs*: as in ♂ but enlargement of legs I less marked. Ventral spination of legs I as in ♂ but tibiae 2-2-2-1-2. *Epigyne* (Fig. 65I, J).

*Dimensions*: total length 4.44-5.2 mm, carapace length 2.2-2.4 mm. *Ratios*: AM : AL : PM : PL : 10 : 5.5 : 1 : 3.6, AL-PM-PL: 8-7.5; a: 1.03, b: 1.05-1.08, c: 0.43-0.44, e: 0.76 (2 ♀ examined).

One of the two paratype females has the abdominal scuta contiguous and poorly defined and its presence is probably of no value as a diagnostic character.

BIOLOGY. Unknown.

DISTRIBUTION. Kenya.

MATERIAL EXAMINED. Holotype ♂, KENYA, Kilifi, swept from low bushes and shrubs in a hot, dry sandy garden, 11.viii.1974 (J. & F. Murphy, vial 4048) (BMNH, reg. no. 1975.11.25.9). Paratypes. 2 ♀, same data as holotype.

ETYMOLOGY. The specific name is a noun in apposition taken from the type-locality.

### *Myrmarachne andrewi* sp. n.

(Figs 66B-E, G, H, J; 67A, D, E)

DIAGNOSIS. *M. andrewi* is a distinctive species readily distinguished from other members of the *volatilis*-group by the form of the body (Fig. 66B, G).

MALE. *Carapace* (Fig. 66B, G): punctured-reticulate; brown-black. *Eyes*: anteriors contiguous with apices procurved, fringed with whitish hairs. *Clypeus*: sparsely white haired. *Chelicerae* (Fig. 66D, H, J): almost vertical; rugulose with small retrolateral and distal, prolateral spurs; glistening dark brown with black lateral keels; fang with 2 apophyses (in ventral view). *Maxillae and Labium*: yellow-brown, labium darker. *Sternum* (Fig. 66E): yellow-brown with blackish mottling. *Abdomen* (Fig. 66B, G): grey yellow mottled with blackish; dorsal scuta dark orange-brown; ventral scutum orange-brown; sparsely white haired. *Legs*: legs I with femora, trochanters and coxae enlarged; yellow-brown with brown-black femora. Legs II and III yellow-brown.

Legs IV yellow-brown with femora, trochanters and coxae darker. Ventral spination of legs I; metatarsi 2-2, tibiae 2-2-2-2 or 2-2-2-2-1, patellae 0. *Palp* (Fig. 67A, D).

*Dimensions*: total length 4.34-4.96 mm, carapace length 1.84-2.04 mm. *Ratios*: AM : AL : PM : PL: 7 : 4 : 1 : 4, AL-PM-PL: 6.5-4.6; a: 1.02, b: 1.02, c: 0.40-0.41, d: 0.23-0.29, e: 0.64-0.65 (2♂ examined).

FEMALE. *Carapace* (Fig. 66C): brown-black with a metallic sheen. *Eyes*: as in ♂. *Clypeus*: as in ♂. *Chelicerae*: orange-brown, mottled with blackish; teeth not examined. *Maxillae and Labium*: brown-black with inner distal margin of maxillae and labial tip yellow-brown. *Sternum*: elongate;

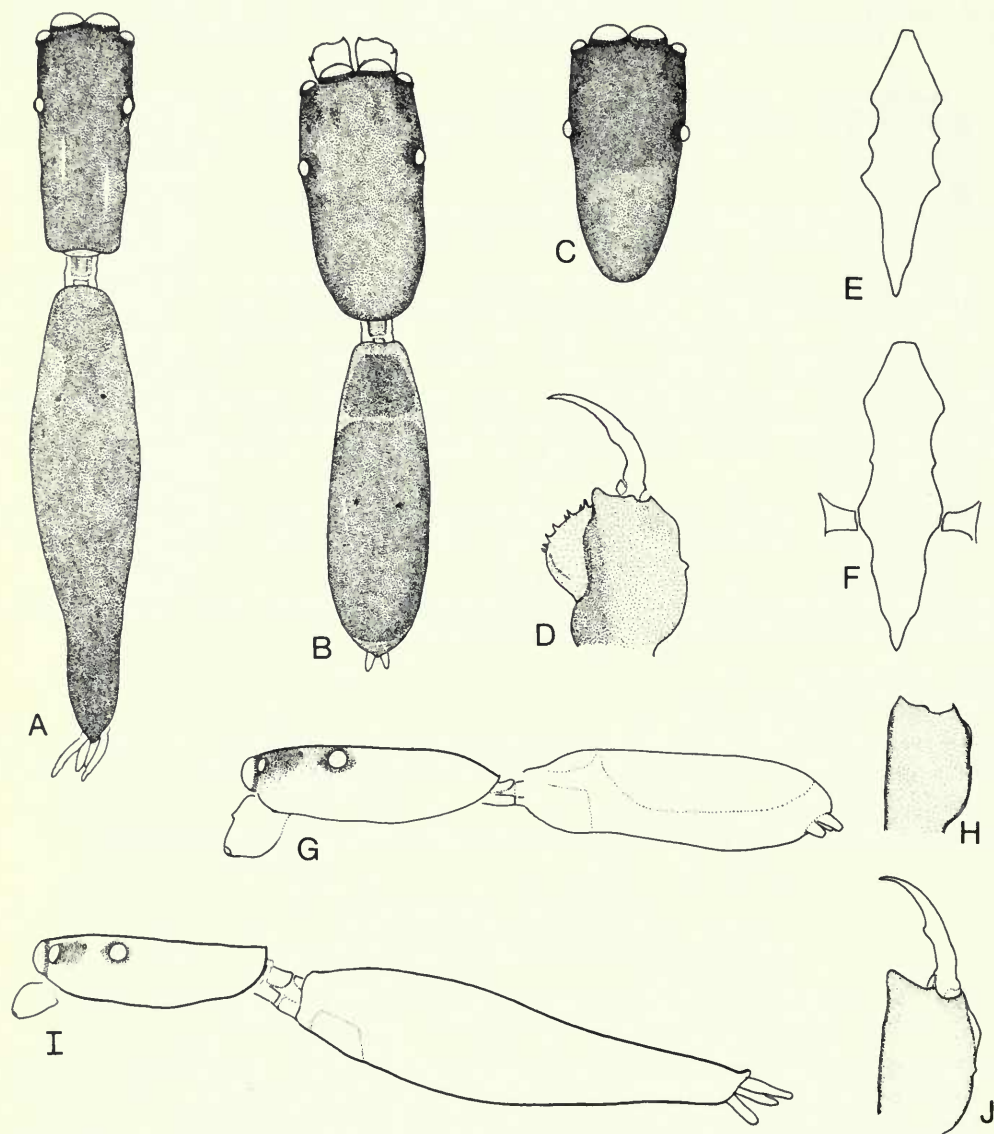

Fig. 66 (A, F, I) *Myrmarachne longiventris* (Simon). Neotype ♀: (A) dorsal view; (F) sternum; (I) lateral view. (B-E, G, H, J) *Myrmarachne andrewi* sp. n. Holotype ♂: (B) dorsal view; (E) sternum; (G) lateral view; (H) chelicera, dorsal view. ♂ from Angola: (D) chelicera, dorsal view but slightly to one side, to show distal lobe; (J) chelicera, dorsal view. Paratype ♀: (C) carapace, dorsal view.

mottled brownish black. *Abdomen*: similar to male; yellow-brown mottled with black; scuta lacking. *Legs*: light yellow-brown with coxae, trochanters and proximal part of femora IV blackish; also a black streak in side of femora I. Ventral spination of legs I: as in ♂ but tibiae with 2-2-2-2-1 spines. *Epigyne* (Fig. 67E): internal structures not examined.

*Dimensions*: total length 4.5 mm, carapace length 1.76 mm. *Ratios*: AM : AL : PM : PL : 7 : 4 : 1 : 4, AL-PM-PL: 6-4-5; a: 1.05, b: 1.11, c: 0.40, e: 0.62 (1 ♀ examined).

A larger male from Angola has an orange carapace and abdomen; the cheliceral spurs are more pronounced (Fig. 66D).

**BIOLOGY.** Unknown.

**DISTRIBUTION.** Angola, Zaire.

**MATERIAL EXAMINED.** Holotype ♂, ZAIRE, Mwenga Territory, Post Kitutu, Elila Valley, secondary forest, 650 m, 6.iv.1958 (*N. Leleup*, MT 142456) (MRAC, Tervuren). Paratypes. ANGOLA: Dundo, Chitato River, route frontiere Dundo, with sweep net, 1 ♂, 26.ix.1946 (*A. B. Machado*, Ang. 46.8) (BMNH). ZAIRE: Kinshasa, 1 ♀, 1.iv.1971 (*A. Bouillon*, MT 142456) (MRAC, Tervuren).

**ETYMOLOGY.** This species is named after my son Andrew Wanless.

*Myrmarachne longiventris* (Simon) comb. n.

(Figs 66A, F, I; 67B, C)

*Bizone longiventris* Simon, 1903 : 1050, ♀. Holotype ♀, Madagascar, Sakavalana (MNHN, Paris) [not examined, ? lost].

*Bizonella longiventris*: Strand, 1929 : 15. Roewer, 1954 : 939. Bonnet, 1955 : 887. Roewer, 1965 : 80, fig. 71. Prószyński, 1971b : 385.

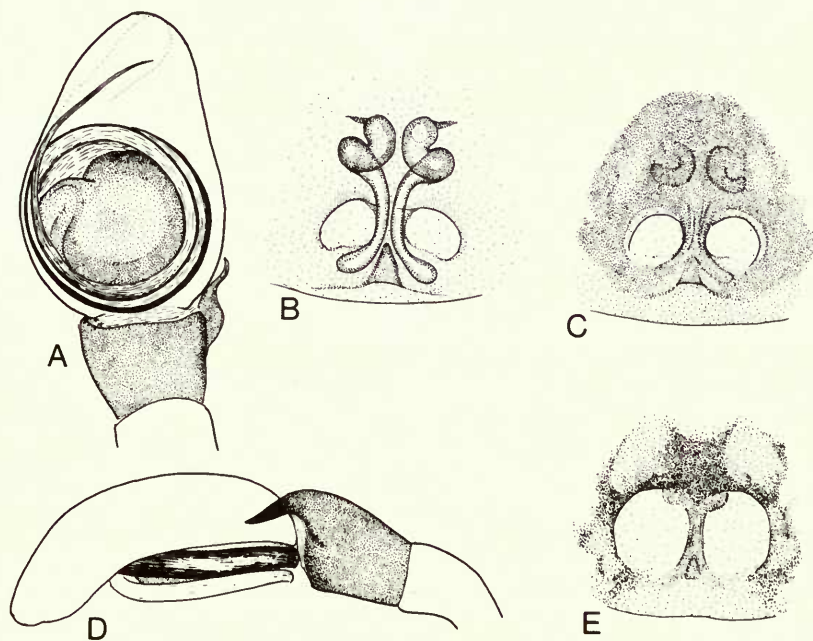

**Fig. 67** (A, D, E) *Myrmarachne andrewi* sp. n. Holotype ♂: (A) palp, ventral view; (D) palp, lateral view. Paratype ♀: (E) epigyne, ventral view. (B, C) *Myrmarachne longiventris* (Simon). Neotype ♀: (B) vulva, ventral view; (C) epigyne, ventral view.



Roewer (1965) described and figured the holotype female of this species which has been subsequently lost. The only example of *longiventris* in the Simon collection, Paris, is an immature female labelled '22230 *Bizone longiventris* E. S. Madagascar'. This specimen is identical to immatures collected with an adult female that is described below and here formally designated neotype.

**DIAGNOSIS.** *M. longiventris* is a very distinctive species. The female is readily separated from other female *Myrmarachne* in the Ethiopian region by the form of the carapace which lacks a thoracic slope (Fig. 66I). The epigyne (Fig. 67C, B) is characteristic of the *volatilis*-group but in the absence of the male any conclusions on the affinities of this species must be regarded as tentative.

**MALE.** Unknown.

**FEMALE.** *Carapace* (Fig. 66A, I): finely rugulose to punctate; dark mahogany, glossy. *Eyes*: contiguous with apices procurved, sparsely fringed with light brown hairs. *Clypeus*: sparsely brown haired. *Chelicerae*: light brown with blackish markings; promargin with 3 teeth, retro-margin with 5. *Maxillae and Labium*: brown with inner distal margins of maxillae and labial tip yellow-brown. *Sternum* (Fig. 66F): orange-brown, glossy under some lights, with scattered light brown hairs. *Abdomen* (Fig. 66A, I): yellow-brown suffused with black glossy under some lights, with scattered light brown hairs. *Legs*: yellow-brown but metatarsi I suffused with black and coxae III-IV marked with black. Ventral spination of legs I: metatarsi 2-2, tibiae 2-2-2-2-2; patellae 0. *Palp*: dark brown. *Epigyne* (Fig. 67B, C).

*Dimensions*: total length 6.4 mm, carapace length 2.0 mm. *Ratios*: AM:AL:PM:PL: 8:4:1:4, AL-PM-PL: 5-6; a: 1.08, b: 1.06, c: 0.40, e: 0.62 (1 ♀ examined).

**BIOLOGY.** Unknown.

**DISTRIBUTION.** Madagascar.

**MATERIAL EXAMINED.** Neotype ♀, MADAGASCAR, Massif Andringitra, Mahasoia, 2100 m, x.1971 (*B. Ranson*, MT 142843). MADAGASCAR: immature ♀ (MNHN, Paris).

**REMARKS.** Female *longiventris* closely resembles female *M. peckhami* Roewer and they may be isopatric as both species have been found in the same vial.

### The *lesserti*-group

This small group is only known from two closely related species, *M. lesserti* Lawrence and *M. albosetosa* sp. n., both from South Africa. Females are unknown but males may be easily distinguished from other male Ethiopian *Myrmarachne* by the unusually long and sinuous tibial apophysis which has a flange arising from the ventral margin (Fig. 69B, C) and a well-developed protuberance on the proximal ectal margin of the cymbium, which appears to protect the apophysis.

The affinities are uncertain but gross morphology resembles that of the *electrica*-group, *M. augusta* (Peckham & Peckham) and *M. diegoensis* sp. n.

#### *Myrmarachne lesserti* Lawrence

(Figs 68A, C, D, F; 69A, B, E-G)

*Myrmarachne lesserti* Lawrence, 1938: 521, fig. 39, ♂. Holotype ♂, South Africa, Durban, The Bluff (NM, Pietermaritzburg) [Examined]. Roewer, 1954: 943. Bonnet, 1957: 3008. Roewer, 1965: 69, fig. 31. Prószyński, 1971b: 439.

**DIAGNOSIS.** *M. lesserti* is a variable species, closely related to *M. albosetosa* sp. n. but can be readily distinguished by the retrolateral spurs on the chelicerae (Fig. 69E, G) and the rectangular palpal tibiae (Fig. 69B).

**FEMALE.** Unknown.

**MALE.** *Carapace* (Fig. 68A, F): punctured-reticulate; orange to reddish with scattered white hairs. *Eyes*: anteriors subcontiguous with apices procurved, sparsely fringed with white hairs. *Clypeus*: sparsely fringed with long fine hairs. *Chelicerae* (Fig. 69E-G): finely rugulose with

furrows; with distal, prolateral and retrolateral spurs; light orange, shiny, with blackish lateral keels; fang apophysis and retrolateral teeth lacking. *Maxillae*: yellowish. *Labium*: yellowish to orange-brown. *Sternum* (Fig. 68D): light orange with darker margins. *Abdomen* (Fig. 68A, F): light yellowish orange with blackish mottling; scuta dark orange with 2 pairs of impressed dots dorsally. *Legs*: legs I (Fig. 68C) the heaviest with femora, trochanters and coxae enlarged; tarsi whitish; metatarsi, tibiae and patellae light yellow; other segments pale orange. Legs II whitish with proximal segments light orange. Legs III-IV light yellowish, a whitish mark on patellae IV. Ventral spination of legs I: metatarsi 2-2, tibiae 2-2-2-2-2-2 or 2-2-2-2-2, patellae 1 or 0. *Palp* (Fig. 69A, B).

*Dimensions*: total length 4.96-7.0 mm, carapace length 2.24-3.48 mm. *Ratios*: AM : AL : PM : PL: 14 : 7 : 2 : 7, AL-PM-PL: 8-7; a: 0.95-1.02, b: 0.98-1.0, c: 0.42-0.44, d: 0.42-0.44, e: 0.83-0.96 (4♂, examined).

**BIOLOGY.** Unknown.

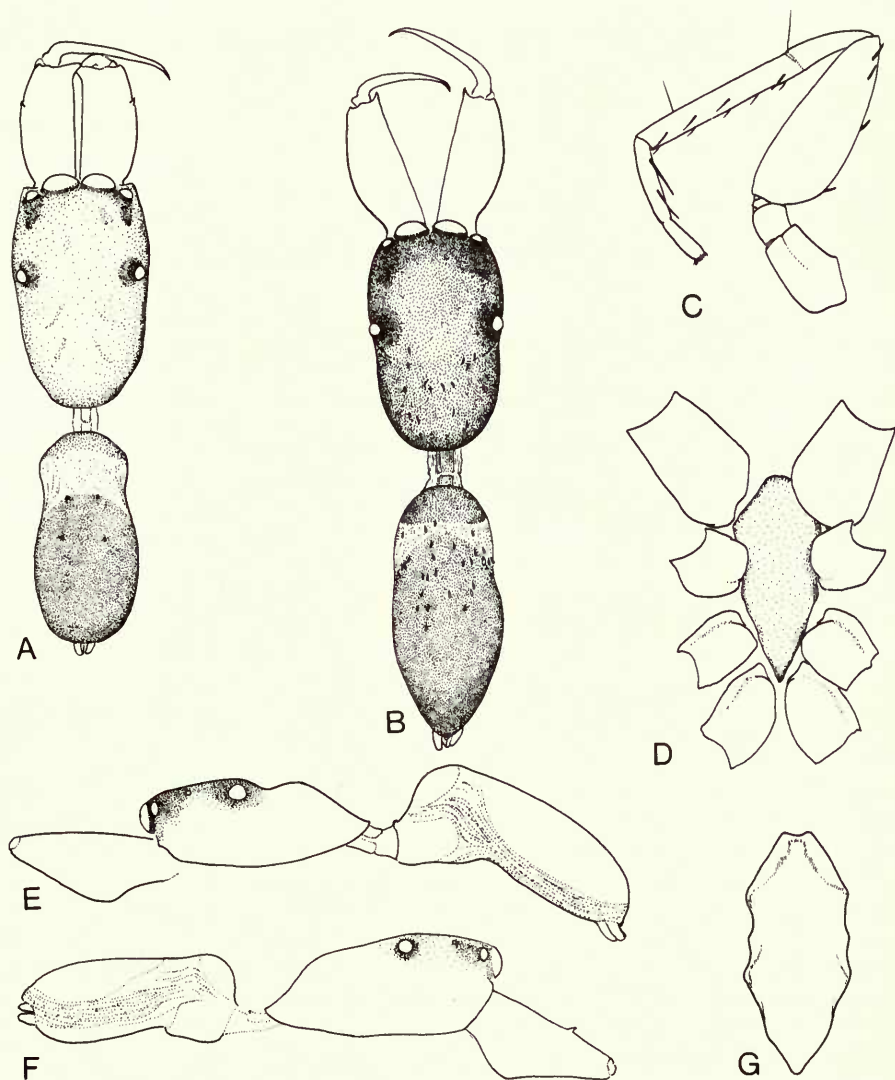

**Fig. 68** (A, C, D, F) *Myrmarachne lesserti* Lawrence. ♂ from South Africa: (A) dorsal view; (C) leg I; (D) sternum; (F) lateral view. (B, E, G) *Myrmarachne albosetosa* sp. n. Holotype ♂: (B) dorsal view; (E) lateral view; (G) sternum.



DISTRIBUTION. South Africa.

MATERIAL EXAMINED. Holotype ♂, data given in synonymy. SOUTH AFRICA: Natal, Alfred District, Oribi Gorge, in litter, 1♂, xi.1961 (*N. Leleup*, MT 132317) (MRAC, Tervuren). Natal, 1♂ (*C. Martin*), Zululand, 1♂ (*C. Martin*) (MNHN, Paris).

*Myrmarachne albosetosa* sp. n.

(Figs 68B, E, G; 69C, D, H-J)

The Peckhams labelled the holotype of this species *Myrmarachne solitarius* Peckham. The original label gives South African Museum as the locality but with Museum carefully crossed out. The specimen probably came from Cape Town but there is some doubt (Dr H. W. Levi, pers. comm.).

DIAGNOSIS. *M. albosetosa* is closely related to *M. lesserti* Lawrence but may be distinguished by the lack of retrolateral spurs on the chelicerae (Fig. 69I, J) and the somewhat bulbous palpal tibiae (Fig. 69C).

FEMALE. Unknown.

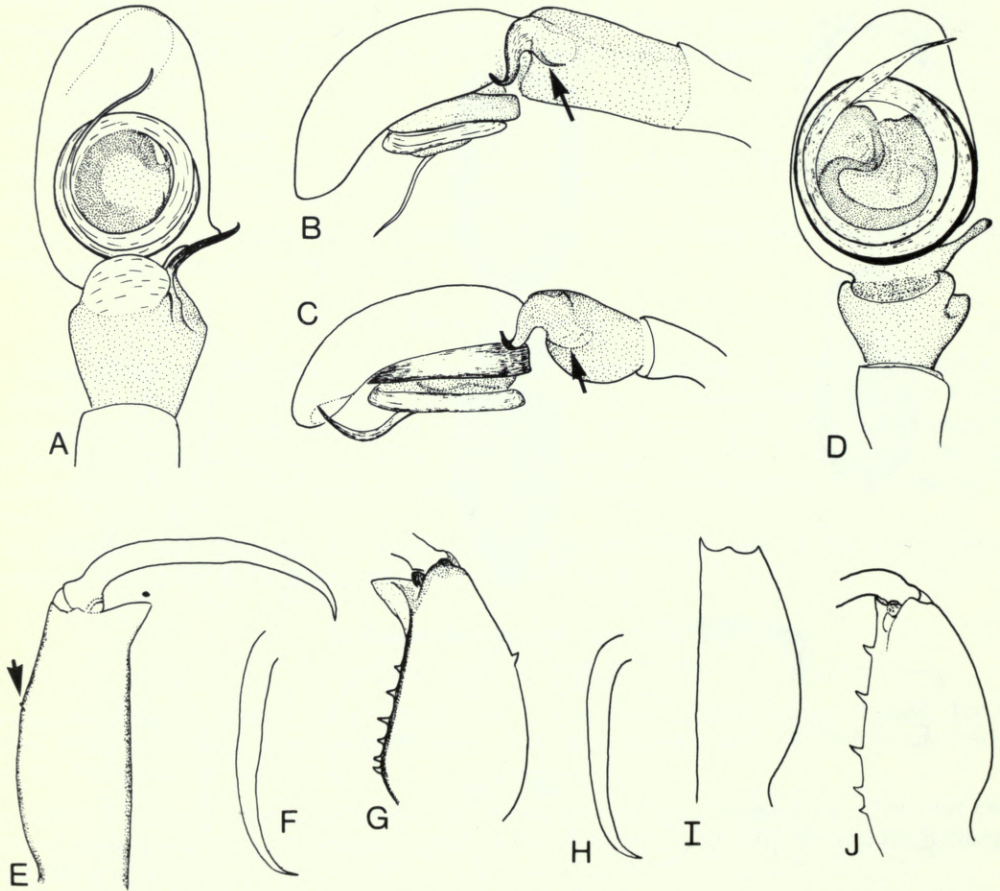

Fig. 69 (A, B, E-G) *Myrmarachne lesserti* Lawrence. ♂ from South Africa: (A) palp, ventral view; (B) palp, lateral view; (E) chelicera, dorsal view; (F) fang; (G) chelicera, ventral view. (C, D, H-J) *Myrmarachne albosetosa* sp. n. Holotype ♂: (C) palp, lateral view; (D) palp, ventral view; (H) fang; (I) chelicera, dorsal view; (J) chelicera, ventral view.



MALE. *Carapace* (Fig. 68B, E): punctured-reticulate; reddish brown with scattered white lanceolate hairs. *Eyes*: anteriors subcontiguous with apices more or less level, fringed with white hairs. *Clypeus*: sparsely white haired. *Chelicerae* (Fig. 69H–J): horizontal but dorsal surface with an inward slope; rugulose with small, distal, prolateral spurs; brownish orange, shiny with blackish lateral keels; fang apophysis lacking; fang groove with promarginal teeth and minute retro-marginal denticles. *Maxillae*: yellow-brown tinged with some black. *Labium*: orange-brown. *Sternum* (Fig. 68G): orange-brown with darker margins. *Abdomen* (Fig. 68B, E): yellow-brown with blackish mottling; scuta orange-brown, shiny under some lights; sparsely covered with white lanceolate hairs. *Legs*: femora I slightly enlarged. Legs I–II with tarsi light yellow-brown; metatarsi, tibiae and patellae yellow-brown with darker sides; femora dark brown with distal yellowish patch; trochanters brown; coxae yellow with brown sides. Legs III brown grading to light brown distally. Legs IV as III but trochanters and venter of coxae yellow. Ventral spination of legs I: metatarsi 2–2, tibiae 2–2–2, patellae 0. *Palp* (Fig. 69C, D).

*Dimensions*: total length 4.0 mm, carapace length 1.68 mm. *Ratios*: AM : AL : PM : PL : 6 : 3.5 : 1 : 3.5, AL–PM–PL: 5.5–7.5; a: 0.98, b: 1.02, c: 0.45, d: 0.54, e: 0.86 (1 ♂ examined).

BIOLOGY. Unknown.

DISTRIBUTION. South Africa.

MATERIAL EXAMINED. Holotype ♂, South Africa, ? Cape Town (MCZ, Harvard).

ETYMOLOGY. The specific name refers to the scattered white setae on the body.

### Species Sola

#### *Myrmarachne augusta* (Peckham & Peckham)

(Fig. 70A–H)

*Salticus augustus* Peckham & Peckham, 1892 : 24, pl. 1, fig. 5, ♂. LECTOTYPE ♂ (here designated), Madagascar (MCZ, Harvard) [Examined].

*Myrmarachne angustiformis* Simon, 1901 : 503. Nom. nov pro *augusta* Peckham & Peckham, non *augusta* Thorell. [Unjustified emendation.]

*Myrmarachne augusta*: Roewer, 1954 : 942. Bonnet, 1957 : 2999. Roewer, 1965 : 63. Prószyński, 1971b : 436.

The Peckhams described and figured a variety of this species. The specimen, a male with long chelicerae, represents another species that is described elsewhere in this present paper (*M. cowanii*, p. 73).

DIAGNOSIS. *M. augusta* is a distinctive species of uncertain affinities, readily distinguished from all other male, Ethiopian *Myrmarachne* by the form of the chelicerae (Fig. 70C, H) and structure of the palp (Fig. 70B, F).

FEMALE. Unknown.

MALE. *Carapace* (Fig. 70A, E): punctured-reticulate; dark reddish orange, shiny with scattered, very fine brownish hairs. *Eyes*: subcontiguous with apices procurved, fringed with whitish hairs. *Clypeus*: white haired. *Chelicerae* (Fig. 70C, H): rugulose with furrows, with paired, distal, prolateral spurs; reddish orange, shiny, with blackish lateral keels; fang apophysis and retro-marginal teeth lacking. *Maxillae and Labium*: orange-brown, labium darker. *Sternum* (Fig. 70G): orange, shiny. *Abdomen* (Fig. 70A, E): brownish orange mottled with blackish; scuta reddish orange tinged with black, glossy. *Legs*: legs I femora, trochanters and coxae slightly enlarged; orange-brown but coxae, and tibiae distally light yellowish. Other legs generally orange-brown but with light yellowish on trochanters IV and patellae IV. Ventral spination of legs I: metatarsi 2–2; tibiae 2–2–2–2, patellae 0. *Palp* (Fig. 70B, F): the secondary tibial apophysis is not very conspicuous.

*Dimensions*: total length 4.2–6.9 mm, carapace length 1.9–3.3 mm, *Ratios*: AM : AL : PM : PL : 8 : 4 : 1 : 4.3, AL–PM–PL: 6–7; a: 0.9–0.96, b: 0.93–1.0, c: 0.39–0.42, d: 0.67–0.94, e: 0.72–0.88 (3 ♂ examined).

A large ♂ from Antongil Bay has unusually broad chelicerae (Fig. 70H) with a minute retro-lateral spur.

BIOLOGY. Unknown.

DISTRIBUTION. Madagascar.

MATERIAL EXAMINED. Lectotype ♂, data given in synonymy. MADAGASCAR: Antongil Bay, 2♂ (*A. Mocqueries*) (MNHN, Paris).

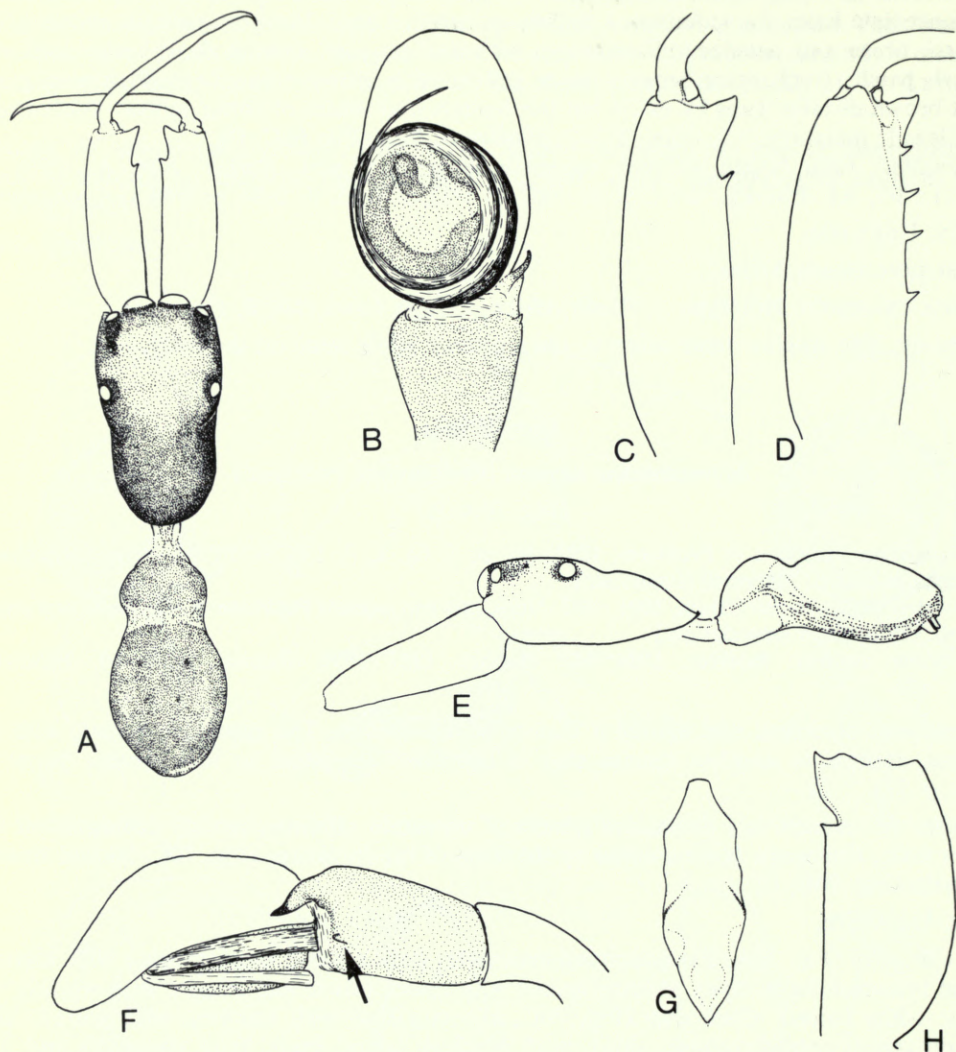

Fig. 70 *Myrmarachne augusta* (Peckham & Peckham). ♂: (A) dorsal view; (B) palp, ventral view; (C) chelicera, dorsal view; (D) chelicera ventral view; (E) lateral view; (F) palp, lateral view; (G) sternum. ♂ from Antongil, (H) chelicera, dorsal view.

#### The *nubilis*-group

This group is known only from females and comprises two species, *M. nubilis* sp. n. and *M. mahasoa* sp. n., both from Madagascar. They are distinguished from other female Ethiopian *Myrmarachne* by the median subtriangular pouch; unusually complex spermathecae and vague distal seminal ducts (Fig. 72A-F).

The affinities are uncertain but it is possible that *M. nubilis* may belong with *M. augusta* (Peckham & Peckham), a species already described as having uncertain affinities and treated as species sola.

*Myrmarachne nubilis* sp. n.

(Figs 71A-C; 72A-C)

**DIAGNOSIS.** *M. nubilis* most closely resembles *M. mahasoa* sp. n. but can be distinguished by the lack of a thoracic 'hump' (Fig. 71B) and the form of the spermathecae (Fig. 72A-C).

**MALE.** Unknown but this species has been found (in vials) with males of *M. augusta* (Peckham & Peckham) and *M. simplexella* (Peckham & Peckham). The relationship is uncertain but female genitalia indicate that *nubilis* is more likely to belong with *augusta*.

**FEMALE.** *Carapace* (Fig. 71A, B): punctured-reticulate in eye region with poorly defined ripples between PL to densely papillate on thoracic part; dark reddish with scattered, long, fine white hairs on thorax. *Eyes*: anterior subcontiguous with apices procurved, fringed with white hairs. *Clypeus*: sparsely white haired. *Chelicerae*: rugulose; brownish orange, shiny; promargin with 5 teeth, retromargin with 9. *Maxillae and Labium*: brownish orange with inner margins of maxillae and labial tip paler. *Sternum* (Fig. 71C): light yellow brown. *Abdomen* (Fig. 71A): yellow-brown suffused and mottled with blackish. *Legs*: legs I yellowish with metatarsi and sides of tibiae, patellae and femora brownish black. Legs II as I but markings lighter, the femora yellowish with an elongate black spot on inner surface. Legs III brownish orange with yellowish marks on patellae and tibiae. Legs IV as III but coxae and trochanters yellowish, the latter with a brown external stripe. Ventral spination of legs I: metatarsi 2-2, tibiae 2-2-2-2-2, patellae 1. *Epigyne* (Fig. 72A-C).

*Dimensions*: total length 4.64-4.88 mm, carapace length 2.12-2.32 mm. *Ratios*: AM : AL : PM : PL: 9.5 : 5 : 1.3 : 6, AL-PM-PL: 6-5, a: 1.03, b: 1.08-1.09, c: 0.40-0.43, e: 0.69-0.70 (2♀ examined).

**BIOLOGY.** Unknown.

**DISTRIBUTION.** Madagascar.

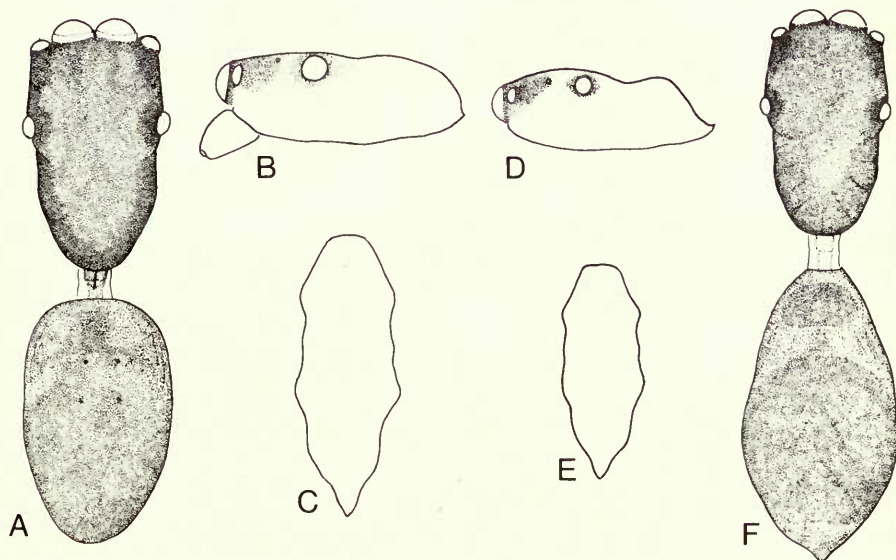

**Fig. 71** (A-C) *Myrmarachne nubilis* sp. n. Holotype ♀: (A) dorsal view; (B) carapace, lateral view; (C) sternum. (D-F) *Myrmarachne mahasoa* sp. n. Holotype ♀: (D) carapace, lateral view; (E) sternum; (F) dorsal view.



MATERIAL EXAMINED. Holotype ♀, MADAGASCAR, Antongil Bay (*A. Mocqueries*, MNHN 7433) (MNHN, Paris). Paratype. MADAGASCAR: Antongil Bay (*A. Mocqueries*, MNHN 20212) (MNHN, Paris).

ETYMOLOGY. The specific name is a latin adjective meaning marriageable.

*Myrmarachne mahasoa* sp. n.

(Figs 71D–F; 72D–F)

DIAGNOSIS. *M. mahasoa* most closely resembles *M. nubilis* sp. n. but can be distinguished by the thoracic 'hump' (Fig. 71D) and the form of the spermathecae (Fig. 72D).

MALE. Unknown.

FEMALE. *Carapace* (Fig. 71D, F): finely punctured-reticulate; orange-brown with sooty marks on thoracic part, shiny. *Eyes*: contiguous with apices procurved, fringed with white hairs. *Clypeus*: sparsely white haired. *Chelicerae*: rugulose; orange-brown, shiny, with 5 teeth on both margins. *Maxillae and Labium*: orange-brown tinged with black with inner margin of maxillae and labial tip paler. *Sternum* (Fig. 71E): yellow-brown with darker margins, shiny. *Abdomen* (Fig. 71F): yellow-brown mottled with black; scuta light brown tinged with black with vague chevrons, shiny. *Legs*: legs I tarsi whitish yellow; metatarsi orange-brown; tibiae and patellae light yellow-brown with brownish lateral streaks; femora orange-brown with sides and venter whitish yellow distally; trochanters orange-brown; coxae whitish yellow. Legs II as I but femora and trochanters whitish yellow, the former with an orange-brown stripe inside. Legs III tarsi light yellow-brown; tibiae yellow-brown with orange-brown sides; remaining segments orange-brown. Legs IV tarsi yellow-brown; coxae and trochanters whitish yellow; remaining segments orange-brown but with whitish marks on patellae. Ventral spination of legs I: metatarsi 2–2, tibiae 2–2–2, patellae 1. *Epigyne* (Fig. 72D–F).

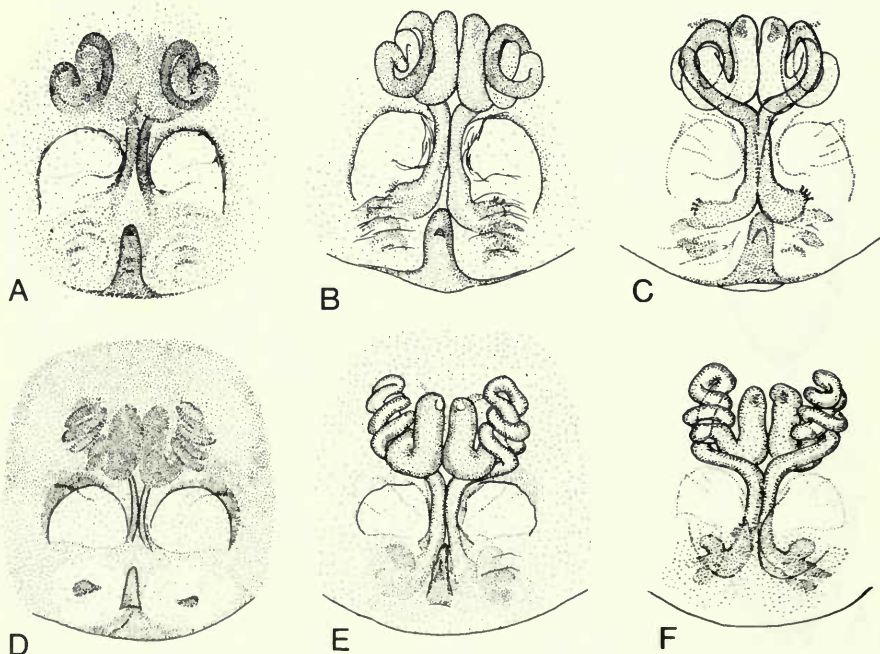

Fig. 72 (A–C) *Myrmarachne nubilis* sp. n. Holotype ♀: (A) epigyne, ventral view; (B) vulva, ventral view; (C) vulva, dorsal view. (D–F) *Myrmarachne mahasoa* sp. n. Holotype ♀: (D) epigyne, ventral view; (E) vulva, ventral view; (F) vulva, dorsal view.

*Dimensions:* total length 4.04 mm, carapace length 1.62 mm. *Ratios:* AM : AL : PM : PL : 7 : 3.5 : 1 : 4, AL-PM-PL: 5.5-5.5; a: 1.04, b: 1.08, c: 0.45, e: 0.74 (1 ♀ examined).

*BIOLOGY.* Unknown.

*DISTRIBUTION.* Madagascar.

*MATERIAL EXAMINED.* Holotype ♀, MADAGASCAR, Massif Andringitra, Mahasoa, 2100 m, x.1971 (*B. Ranson*, MT 142876) (MRAC, Tervuren).

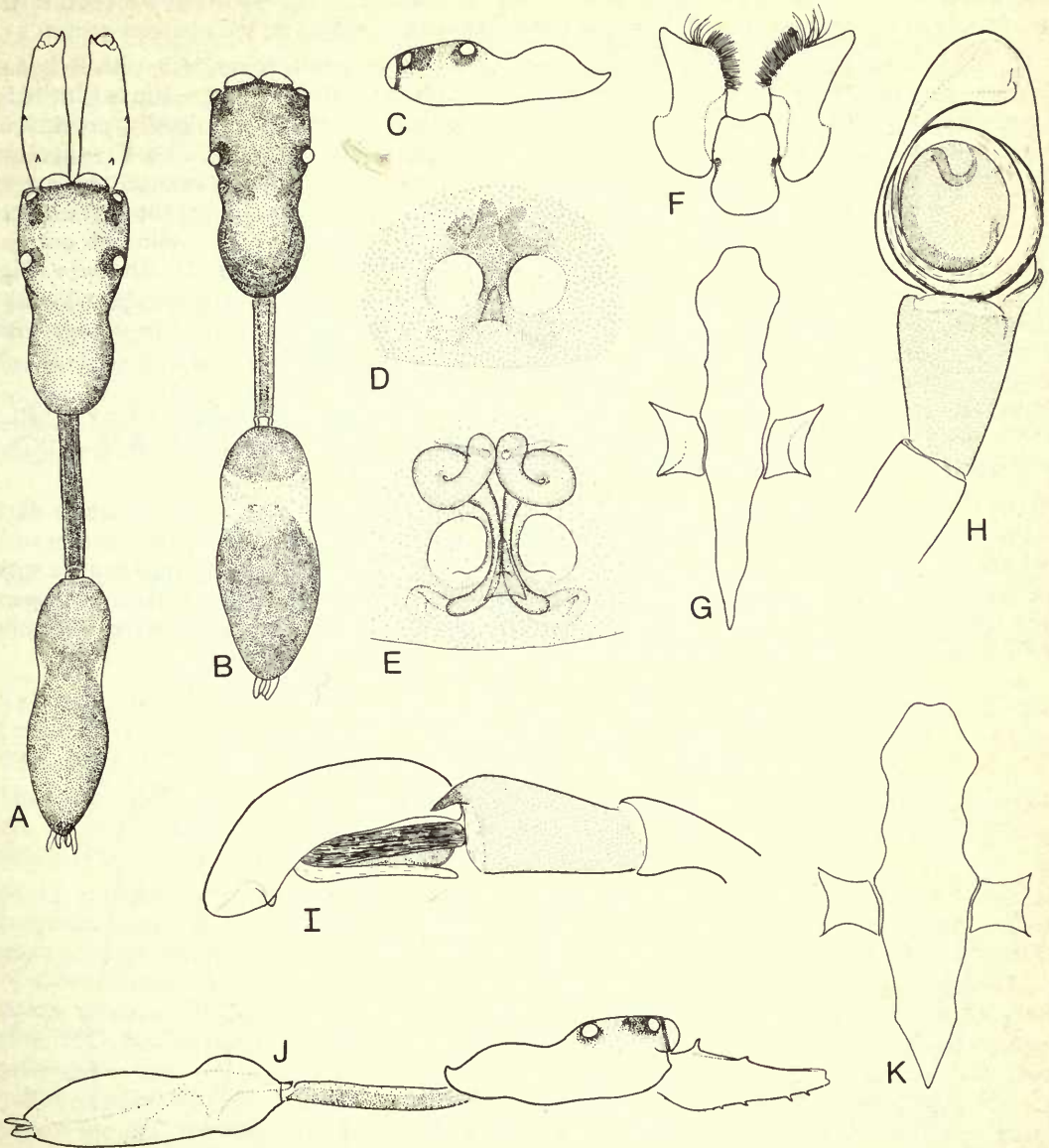

**Fig. 73** *Myrmarachne eumenes* (Simon). ♂ from Antongil: (A) dorsal view; (F) maxillae and labium; (G) sternum; (H) palp, ventral view; (I) palp, lateral view; (J) lateral view; (K) sternum of another Antongil ♂. ♀ from Est Antsirabe: (B) dorsal view; (C) carapace, lateral view; (D) epigyne, ventral view; (E) vulva ventral view.



## Species Sola

### *Myrmarachne eumenes* (Simon)

(Figs 73A–K; 74A–E; Pl. 2b)

*Salticus eumenes* Simon, 1900 : 405, ♂. LECTOTYPE ♂ (here designated), Madagascar, Nossi-Be (MNHN, Paris) [Examined].

*Myrmarachne eumenes* (Simon): Simon, 1901 : 499, figs 587–589. Roewer, 1954 : 942. Bonnet, 1957 : 3002. Roewer, 1965 : 66, fig. 29. Prószyński, 1971b : 437.

**DIAGNOSIS.** The exceedingly long pedicel is diagnostic for *M. eumenes*. It is a species of uncertain affinities but the relatively short, filamentous tip of the embolus (Fig. 73H, I) and looped distal sperm ducts of the epigyne (Fig. 73E) suggest that *eumenes* is related to the *electrica*-group.

**MALE.** *Carapace* (Fig. 73A, J; Pl. 2b): finely reticulate in eye region to smooth with irregular punctures on thoracic part with transverse furrows posteriorly; dark reddish, shiny, with light orange guanin in eye region. *Eyes*: anteriors subcontiguous with apices slightly procurved, fringed with whitish hairs. *Clypeus*: sparsely brown haired. *Chelicerae* (Fig. 74A–E): rugulose with furrows with distal prolateral, retrolateral and proximal median spurs; orange, shiny with blackish lateral keels; fang apophysis lacking. *Maxillae and Labium* (Fig. 73F): yellowish orange, with outer distal margin of maxillae drawn to a point. *Sternum* (Fig. 73G): yellowish orange. *Pedicel*: exceedingly long (ratio of anterior to posterior segments about 10 : 1). *Abdomen* (Fig. 73A, J): light orange brown mottled with grey, the venter and lower sides of constriction yellowish; scuta ill-defined, orange-brown tinged with grey, shiny. *Legs*: yellowish orange to orange with metatarsi I blackish. Ventral spination of legs I: metatarsi 2–2, tibiae 2–2–2–2–2 or 2–2–2–2, patellae 1. *Palp* (Fig. 73H, I).

*Dimensions*: total length 5.6–8.7 mm, carapace length 2.5–3.2 mm. *Ratios*: AM : AL : PM : PL : 10 : 5 : 1 : 5.5, AL–PM–PL: 6.5–7; a: 0.92–1.0, b: 0.98–1.02, c: 0.37–0.38, d: 0.50–0.74, e: 0.78–0.92; pedicel length to carapace length 0.30–0.74 (10 ♂ examined).

**FEMALE** (formerly undescribed). *Carapace* (Fig. 73B, C): more or less as in ♂, orange to dark reddish, shiny. *Eyes*: as in ♂. *Clypeus*: as in ♂. *Chelicerae*: rugulose; light orange; promargin with 4–6 teeth retromargin with 6 or 7. *Maxillae and Labium*: typical of genus; brownish orange with inner margins of maxillae and labial tip lighter. *Sternum*: orange with darker margins. *Abdomen* (Fig. 73B): whitish yellow with poorly defined orange-brown scuta; thinly covered with fine light orange hairs. *Legs*: as in ♂. *Epigyne* (Fig. 73D, E).

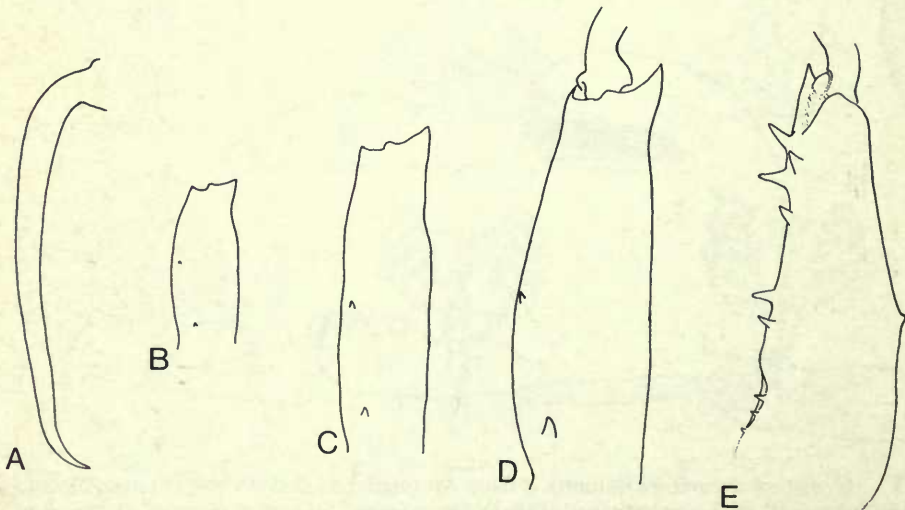

**Fig. 74** *Myrmarachne eumenes* (Simon), males from Antongil: (A) fang; (B, C, D) chelicerae, dorsal view, showing variation in size and shape (drawn to scale); (E) chelicera, ventral view.



*Dimensions*: total length 5.4–7.0 mm, carapace length 2.3–2.5 mm. *Ratios*: AM : AL : PM : PL: 10 : 5 : 1 : 5.5, AL–PM–PL: 6.5–7; a: 1.0–1.02, b: 1.0–1.02, c: 0.38–0.39, e: 0.70–0.79 (10 ♀ examined).

Depth of colour varies from pale orange to dark reddish in preserved specimens and the abdomen is often marked with blackish transverse bands. The transverse furrows on the posterior margin of the thorax are sometimes poorly defined and the sternum and male maxillae show slight variations in shape. Male chelicerae grow allometrically with the spurs being more strongly developed in larger specimens.

BIOLOGY. Unknown.

DISTRIBUTION. Madagascar.

MATERIAL EXAMINED. Lectotype ♂, data given in synonymy. MADAGASCAR: Beanana, 1 ♀, vi.1968 (*A. Lambillon*, MT 142972); Beanana, 1 ♂, v.1970 (*A. Lambillon*, MT 142812); Beanana, 1 ♀, ii.1970 (*A. Lambillon*, MT 142614); Est Antsirabe, 2 ♀, 10.x.1970 (*J. Gossuin*, MT 142530, 142576); Vohibe, 1 ♂, 1 immature, vii.1970 (*A. Lambillon*, MT 142783); Massif Andringitra, Mahasoia, 2100 m, 4 ♂, 6 ♀, 11 immatures, x.1971 (*B. Ranson*, MT 142835); Mt. Ambohisanga, 1 ♂, i.1951 (*A. Pierrard*, MT 142918) (MRAC, Tervuren); S. Marie, 1 ♂, (*A. Mocqueries*); Diego-Suarez, 2 ♂, 6 ♀ (*Ch. Alluaud*); Antongil, 35 ♂, 4 ♀ (*A. Mocqueries*) (MNHN, Paris).

### The *electrica*-group

This group is comprised of 4 species from Madagascar, *M. electrica* (Peckham & Peckham), *M. andringitra* sp. n. *M. eugenei* nom. n. and *M. peckhami* Roewer. Males are distinguished by the distally, filamentous embolus (Fig. 80A, B), the absence of a flange and lack of modifications to the proximal ectal margin of the cymbium. Females are separated by the median pouch and coiled, distal seminal ducts (Fig. 77D). The 4 species have similar genitalia but *M. eugenei* has a somewhat divergent body form and differs in carapace shape and sculpturing.

### *Myrmarachne eugenei* nom. n.

(Figs 75A–G; 76A–E; Pl. 2e, f)

*Emertonius rufescens* Simon, 1900 : 405, ♀. LECTOTYPE ♀ (here designated), Madagascar, Diego-Suarez (MNHN, Paris) [Examined]. [Junior secondary homonym of *Myrmarachne rufescens* Thorell, 1877.] Simon, 1901 : 498, 503, 504. Roewer, 1954 : 939. Bonnet, 1957 : 1653. Roewer, 1965 : 78, fig. 70. Prószyński, 1971b : 400.

The male has not previously been described and its discovery makes it clear that this species belongs in the genus *Myrmarachne*. However, the specific name is preoccupied by *M. rufescens* Thorell, 1877. It is now renamed after the original author, M Eugène Simon.

DIAGNOSIS. *M. eugenei* is a very distinctive species readily distinguished from other members of the *electrica*-group by the carapace shape (Fig. 75A, B, F) and unique thoracic sculpturing (Pl. 2e, f).

MALE. *Carapace* (Fig. 75A, F; Pl. 2e, f): finely punctured-reticulate in eye region to irregularly tumulose with scattered piliferous papillae on thoracic part; orange-brown with light yellowish guanin in eye region extending posteriorly to form 3 obscure wedge-shaped marks on hind part of thorax; sparsely clothed with long light brown hairs. *Eyes*: anteriors subcontiguous with apices procurved, fringed with white hairs. *Clypeus*: sparsely fringed with white hairs. *Chelicerae* (Fig. 75D, E, G): rugulose with furrows, with retrolateral and distal prolateral spurs; orange to yellowish orange with blackish lateral keels, shiny; fang apophysis lacking. *Maxillae and Labium*: yellow-orange, with outer distal margin of maxillae drawn to a point. *Sternum* (Fig. 75C): light yellow-orange; sparsely punctured with light orange hairs. *Abdomen* (Fig. 75A, F): anterior margin with distinct cleft; pale yellowish with an undivided light brown scutum and scattered light brown hairs. *Legs*: legs I pale yellowish with metatarsi and sides of tibiae, patellae and femora light orange. Legs II light orange with tarsi and metatarsi pale yellowish. Legs III light orange with distal segments pale yellowish. Legs IV as III but with light orange tibiae. Ventral spination of legs I: metatarsi 2–2, tibiae 2–2–2–2, patellae 0. *Palp* (Fig. 76A, B, D).

*Dimensions*: total length 5.4 mm, carapace length 2.6 mm. *Ratios*: AM : AL : PM : PL : 12.5 : 7 : 2 : 7, AL-PM-PL: 7-8; a: 1.0, b: 0.98, c: 0.46, d: 0.90, e: 0.74 (1 ♂ examined).

**FEMALE.** *Carapace* (Fig. 75B): similar to ♂; orange-brown or dark reddish, the guanin pattern sometimes less conspicuous. *Eyes*: as in ♂. *Clypeus*: as in ♂. *Chelicerae*: finely rugulose; light yellow-brown; promargin with 3 teeth, retromargin with 6 or 7. *Maxillae and Labium*: typical of genus, light yellow-orange. *Sternum*: elongate margins poorly defined; whitish yellow. *Abdomen* (Fig. 75B): greyish yellow sometimes with variable pattern composed of whitish guanin; scuta lacking. *Legs*: whitish. Ventral spination as in ♂ but tibiae 1-2-2-1-2 or 2-2-2-2-2. *Epigyne* (Fig. 76C, E).

*Dimensions*: total length 4.1-4.48 mm, carapace length 1.9-2.12 mm. *Ratios*: AM : AL : PM : PL : 9.5 : 5 : 1 : 5; AL-PM-PL: 7-6; a: 1.03-1.05, b: 1.07-1.09, c: 0.48-0.50, e: 0.65-0.67 (3 ♀ examined).

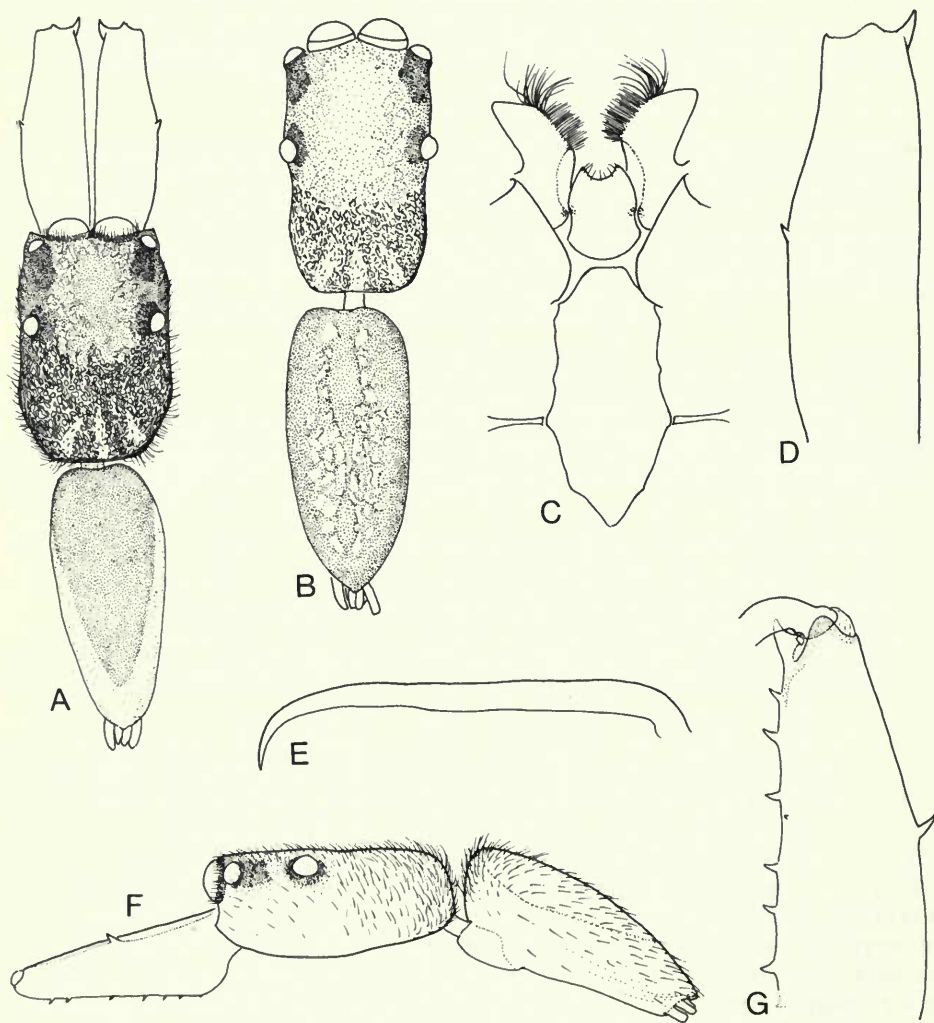

**Fig. 75** *Myrmarachne eugenei* nom. n. ♂ from Antongil Bay: (A) dorsal view; (C) maxillae, labium and sternum; (D) chelicera, dorsal view; (E) fang; (F) lateral view; (G) chelicera, ventral view. Lectotype ♀, (B) dorsal view.

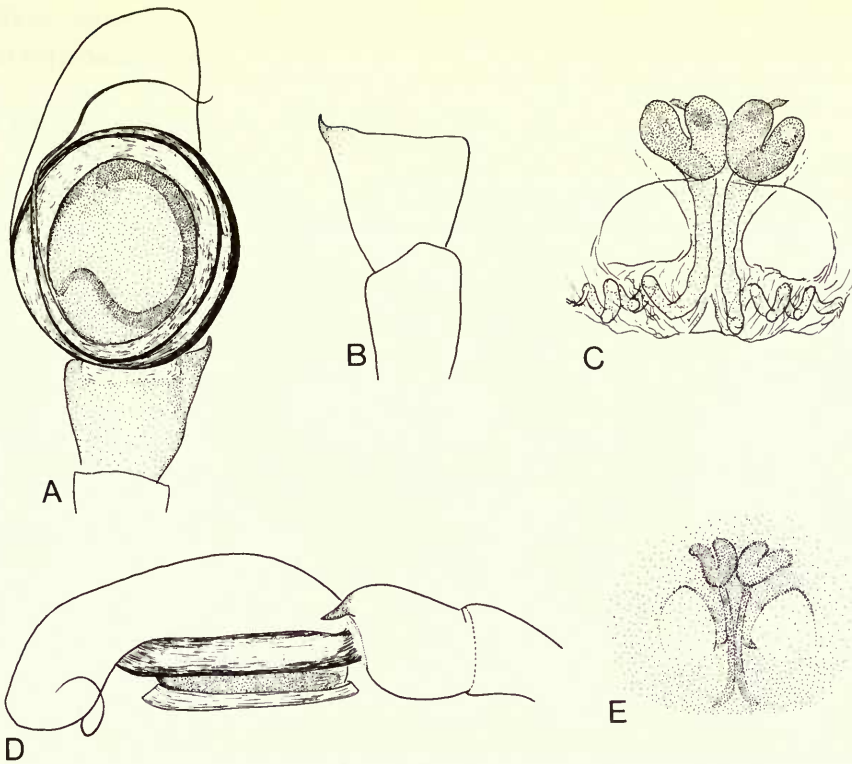

Fig. 76 *Myrmarachne eugenei* nom. n. ♂ from Antongil Bay: (A) palp, ventral view; (B) palpal tibia, dorsal view; (D) palp, lateral view. Lectotype ♀: (C) vulva, ventral view; (E) epigyne, ventral view.

BIOLOGY. Unknown.

DISTRIBUTION. Madagascar.

MATERIAL EXAMINED. Lectotype ♀, data given in synonymy. MADAGASCAR: Mt Ambohisanga, i.1951, 1 ♀ (*A. Pierrard* MT 142920) (MRAC, Tervuren); Beparasy, 1 ♀, ii.1968 (*A. Lambillon*, MT 142737) (MRAC, Tervuren); Beanana, 1 ♀, ii.1970 (*A. Lambillon*, MT 142601) (MRAC, Tervuren); Antongil Bay, 1 ♂ (*C. Alluaud*) (MNHN, Paris).

*Myrmarachne andringitra* sp. n.

(Fig. 77A–D)

DIAGNOSIS. *M. andringitra* is closely related to *M. peckhami* Roewer but may be distinguished by the form of the body (Fig. 77A) and structure of the epigyne (Fig. 77C, D).

MALE. Unknown but *andringitra* is sympatric with *M. simplexella* and could belong with that species.

FEMALE. *Carapace* (Fig. 77A, B): finely punctured-reticulate in eye region; light brownish orange with yellowish guanin in eye region. *Eyes*: anteriors subcontiguous with apices level, fringed with white hairs. *Clypeus*: sparsely fringed with pale hairs. *Chelicerae*: rugulose, yellowish, shiny; promargin with 5 teeth, retromargin with 7. *Maxillae and Labium*: yellowish. *Sternum*: elongate; whitish yellow. *Abdomen* (Fig. 77A): whitish yellow. *Legs*: whitish yellow. Ventral spination of legs I: metatarsi 2–2, tibiae 2–2–2–2–2–2, patellae 1. *Epigyne* (Fig. 77C, D).

*Dimensions*: total length 5.78 mm, carapace length 2.7 mm. *Ratios*: AM : AL : PM : PL: 12.5 : 6.5 : 1 : 7, AL–PM–PL: 9–8; a: 1.04, b: 1.06, c: 0.44, e: 0.94 (1 ♀ examined).

BIOLOGY. Unknown.



DISTRIBUTION. Madagascar.

MATERIAL EXAMINED. Holotype ♂, MADAGASCAR, Massif Andringitra, Mahasoa, 2100 m, x.1971 (B. Ranson, MT 142833) (MRAC, Tervuren).

ETYMOLOGY. The specific name is a noun in apposition based on the region where the holotype was collected.

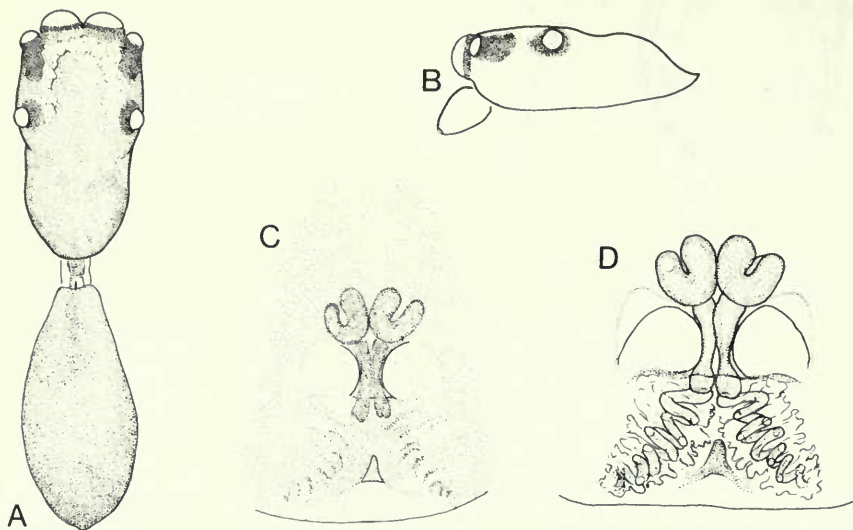

Fig. 77 *Myrmarachne andringitra* sp. n. Holotype ♀: (A) dorsal view; (B) carapace, lateral view; (C) epigyne, ventral view; (D) vulva, ventral view.

*Myrmarachne electrica* (Peckham & Peckham)

(Fig. 78A–F)

*Salticus electricus* Peckham & Peckham, 1892 : 25, pl. 1, figs 3, 3a, 3b, ♂. LECTOTYPE ♂ (here designated), Madagascar (MCZ, Harvard) [Examined].

*Myrmarachne electrica*: Simon, 1901 : 500. Roewer, 1954 : 942. Bonnet, 1957 : 3001. Roewer, 1965 : 65, fig. 32. Prószyński, 1971b : 437.

DIAGNOSIS. *M. electrica* is closely related to *M. peckhami* Roewer but can be distinguished by the apparent lack of thoracic punctures and palp structure (Fig. 78B, D, E). The tibial apophysis is more robust, the embolus has three turns about the tegulum and the reservoir of the ejaculatory duct is proximal and procurved.

FEMALE. Unknown.

MALE. *Carapace* (Fig. 78A, F): finely punctured-reticulate in eye region but too poorly defined to be resolved on thoracic part; light brown with eye region yellowish and sooty marks radiating from constriction. *Eyes*: anteriors subcontiguous with apices procurved, sparsely fringed with fine hairs. *Clypeus*: sparsely white haired. *Chelicerae* (Fig. 78C): finely rugulose with furrows with retrolateral and distal, prolateral spurs; light yellow-brown, shiny; fang apophysis lacking. *Maxillae and Labium*: light yellow. *Sternum*: elongate; light yellow with indistinct margins. *Abdomen* (Fig. 78A, F): light yellow with 2 brownish marks either side of constriction; anterior scuta pale yellow-brown, posterior one ill-defined, yellowish with a brownish mark. *Legs*: I and III light yellow-brown with femora I slightly enlarged; legs II and IV missing. Ventral spination of legs I: metatarsi 2–2, tibiae 2–2–2–2, patellae 0. *Palp* (Fig. 78B, D, E).

*Dimensions*: total length 4.6 mm, carapace length 2.2 mm. *Ratios*: AM : AL : PM : PL: 10.5 : 5.5 : 1 : 5.5, AL–PM–PL: 7–7; a: 1.02, b: 1.02, c: 0.44; d: 0.60 (1 ♂ examined).

BIOLOGY. Unknown.

DISTRIBUTION. Madagascar.

MATERIAL EXAMINED. Lectotype ♂, data given in synonymy.

REMARKS. Although there are a number of characters which distinguish this species from *M. peckhami* I suspect that intermediate forms will be found. The morphology of the embolus and position of the ejaculatory duct may be variable as Kaston (1970) has already described for certain closely related species of *Latrodectus*. The apparent lack of punctures on the thorax of the lectotype specimen of *electrica* does not mean a great deal at the present time as the specimen is somewhat bleached and the sculpturing cannot be properly resolved with the dissecting microscope.

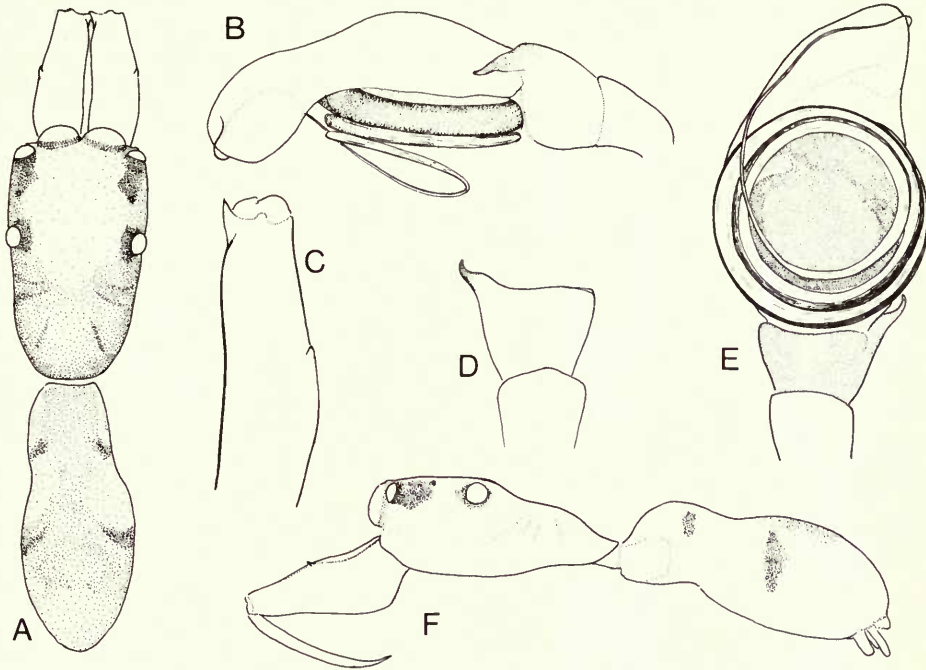

Fig. 78 *Myrmarachne electrica* (Peckham & Peckham). Lectotype ♂: (A) dorsal view; (B) palp, lateral view; (C) chelicera, dorsal view; (D) palpal tibia, dorsal view; (E) palp, ventral view; (F) lateral view.

*Myrmarachne peckhami* Roewer

(Figs 79A-I; 80A-E)

*Salticus gracilis* Peckham & Peckham, 1892 : 26, pl. 2, figs 1, 1a, 1b, ♀. LECTOTYPE ♀ (here designated), Madagascar (MCZ, Harvard) [Examined].

*Myrmarachne peckhami* Roewer, 1951 : 450. *Nom. nov.* pro *Salticus gracilis* Peckham & Peckham, *praeocc.*, Hahn 1831. Roewer, 1954 : 943; 1965 : 67.

*Myrmarachne gracilis*: Bonnet, 1957 : 3006. Prószyński, 1971b : 438.

DIAGNOSIS. *M. peckhami* is closely related to *M. electrica* (Peckham & Peckham) but can be distinguished by the presence of thoracic punctures and palp structure (Fig. 80A, B). The tibial apophysis is more slender, the embolus has two turns around the tegulum and the reservoir of the ejaculatory duct is distal and recurved. However, see remarks under *M. electrica* (p. 000). Female *peckhami* are very similar to female *M. andringitra* but they are separated by the shape of the carapace and abdomen (Fig. 79B, H) also the distal seminal ducts have fewer coils.

MALE. *Carapace* (Fig. 79A, I): very finely rugulose in eye region with punctures on thoracic part radiating from constriction; dark orange-brown with orange guanin in eye region, shiny. *Eyes*: anteriors contiguous with apices procurved, sparsely fringed with whitish hairs. *Clypeus*: sparsely white haired. *Chelicerae* (Fig. 79D, F, G): finely rugulose with furrows, with retrolateral and

distal, prolateral spurs; dark orange-brown, rather shiny; fang apophysis lacking; retromarginal teeth minute. *Maxillae*: yellow-brown. *Labium*: orange with yellow-brown tip. *Sternum* (Fig. 79C): orange with darker margins. *Abdomen* (Fig. 79A, I): whitish yellow with blackish mottling; scuta orange-brown tinged with some black, shiny; ventrally a poorly defined rectangular patch of light yellow. *Legs*: legs I with tarsi, trochanters and coxae light yellowish; metatarsi and femora dark orange; tibiae and patellae light orange. Legs II light yellowish with distal, elongate black spot on inside of femora. Legs III light yellowish with darker femora. Legs IV as III but tibiae and patellae also darker. Ventral spination of legs I: metatarsi 2-2, tibiae 2-2-2-2, patellae 1. *Palp* (Fig. 80A, B).

*Dimensions*: total length 4.24 mm, carapace length 1.82 mm. *Ratios*: AM : AL : PM : PL : 8.5 : 5 : 1 : 4.5, AL-PM-PL: 5.5-5.3; a: 1.04, b: 1.04, c: 0.43, d: 0.59, e: 0.81 (1 ♂ examined).

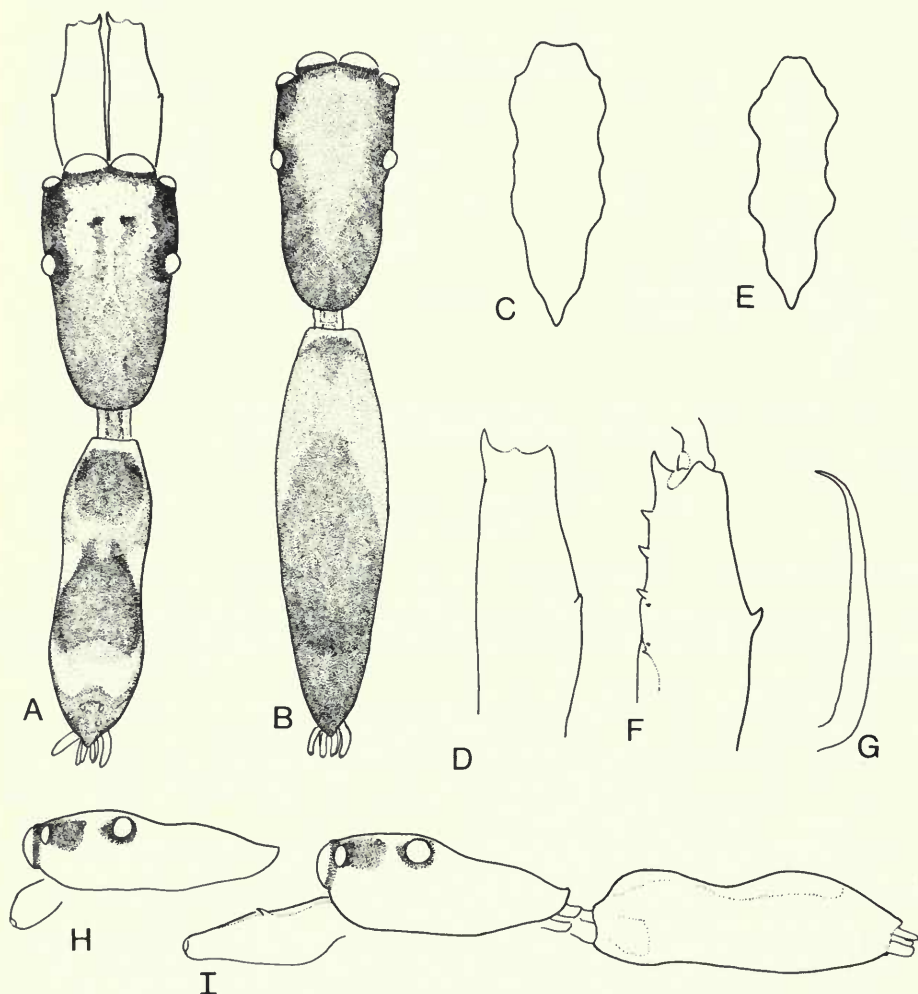

Fig. 79 *Myrmarachne peckhami* Roewer. ♂ from Massif Andringitra: (A) dorsal view; (C) sternum; (D) chelicera, dorsal view; (E) chelicera, ventral view; (G) fang; (I) lateral view. ♀ from same locality: (B) dorsal view; (E) sternum; (H) carapace, lateral view.

FEMALE. *Carapace* (Fig. 79B, H): more or less as in ♂ but eye region very finely rugulose to very finely punctured-reticulate. *Eyes*: as in ♂. *Clypeus*: as in ♂. *Chelicerae*: light brown; promargin with 4 or 5 teeth, retromargin with 6 or 7. *Maxillae and labium*: light brownish orange but inner margin of maxillae and labial tip lighter. *Sternum* (Fig. 79E): light orange, shiny. *Abdomen*:



yellow-tinged with greyish with poorly defined brown-black scuta. *Legs*: legs I tarsi, femora, trochanters and coxae whitish yellow; other segments yellow-orange. Legs II-III as I but tarsi yellow-orange. Legs IV brownish orange with distal segments lighter. Ventral spination of legs I as in ♂. *Epigyne* (Fig. 80C-E): the spermathecal loops show some variation and the coils of the distal seminal ducts are sometimes evident in uncleared epigynes.

*Dimensions*: total length 4.6-6.0 mm, carapace length 1.94-2.16 mm. *Ratios*: AM:AL:PM:PL: 9:5:1:5, AL-PM-PL: 7-6; a: 1.02-1.03, b: 1.03-1.08, c: 0.41-0.43, e: 0.71-0.75 (5 ♀ examined).

**BIOLOGY.** Unknown.

**DISTRIBUTION.** Madagascar.

**MATERIAL EXAMINED.** Lectotype ♀ and paralectotype ♀, data given in synonymy. MADAGASCAR: Massif Andringitra, Mahasoia, 2100 m, 1 ♂, 3 ♀, x.1971 (B. Ranson, MT 142843) (MRAC, Tervuren).

**REMARKS.** *M. peckhami* has been found in the same vial as *M. andringitra* and *M. longiventris*.

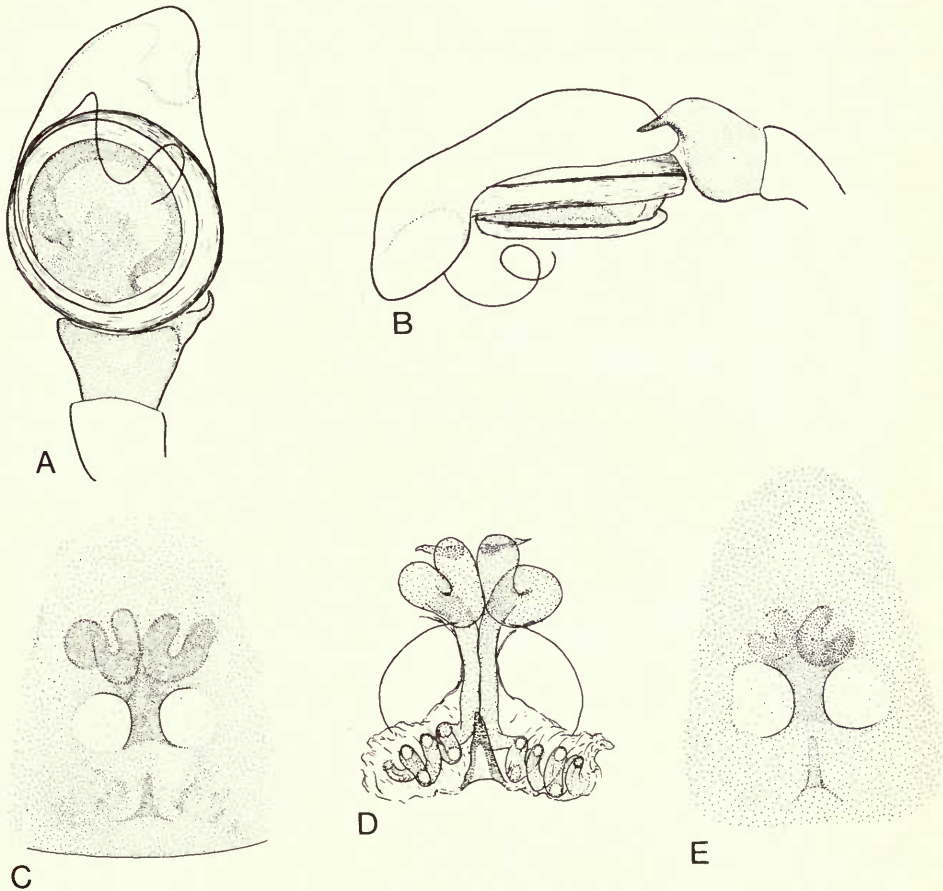

**Fig. 80** *Myrmarachne peckhami* Roewer. ♂ from Massif Andringitra: (A) palp, ventral view; (B) palp, lateral view. ♀ from same locality. (C) epigyne, ventral view. Lectotype female: (D) vulva, ventral view; (E) epigyne, ventral view.

**Species Sola**

*Myrmarachne simplexella* Roewer

(Figs 81A-J; 82A-E)

*Salticus simplex* Peckham & Peckham, 1892: 23, pl. 1, figs 4, 4a, 4b, 4c, ♂. LECTOTYPE ♂ (here designated), Madagascar (MCZ, Harvard) [Examined].

*Myrmarachne simplexella* Roewer, 1951: 450. *Nom. nov.* pro *Salticus simplex* Peckham & Peckham, *praeocc.*, Blackwall 1865. Roewer, 1954: 944; 1965: 67.

*Myrmarachne simplex*: Bonnet, 1957: 3013. Prószyński, 1971b: 440.

DIAGNOSIS. *M. simplexella* is a very variable species of uncertain affinities but the pronounced flange (Fig. 82C–E) with its fringe of long, stout setae is diagnostic.

FEMALE. Unknown but it is possible *M. andringitra* belongs here.

MALE. *Carapace* (Fig. 81A–E, I): punctured-reticulate in eye region with ripples between PL to densely papillate on thoracic part; dark orange-brown with whitish hairs. *Eyes*: anteriors subcontiguous with apices more or less level, fringed with white hairs. *Clypeus*: white haired. *Chelicerae* (Fig. 81F–H, J): finely rugulose; orange-brown with blackish lateral keels; fang apophysis and retromarginal teeth lacking. *Maxillae*: orange-brown. *Labium*: reddish brown with

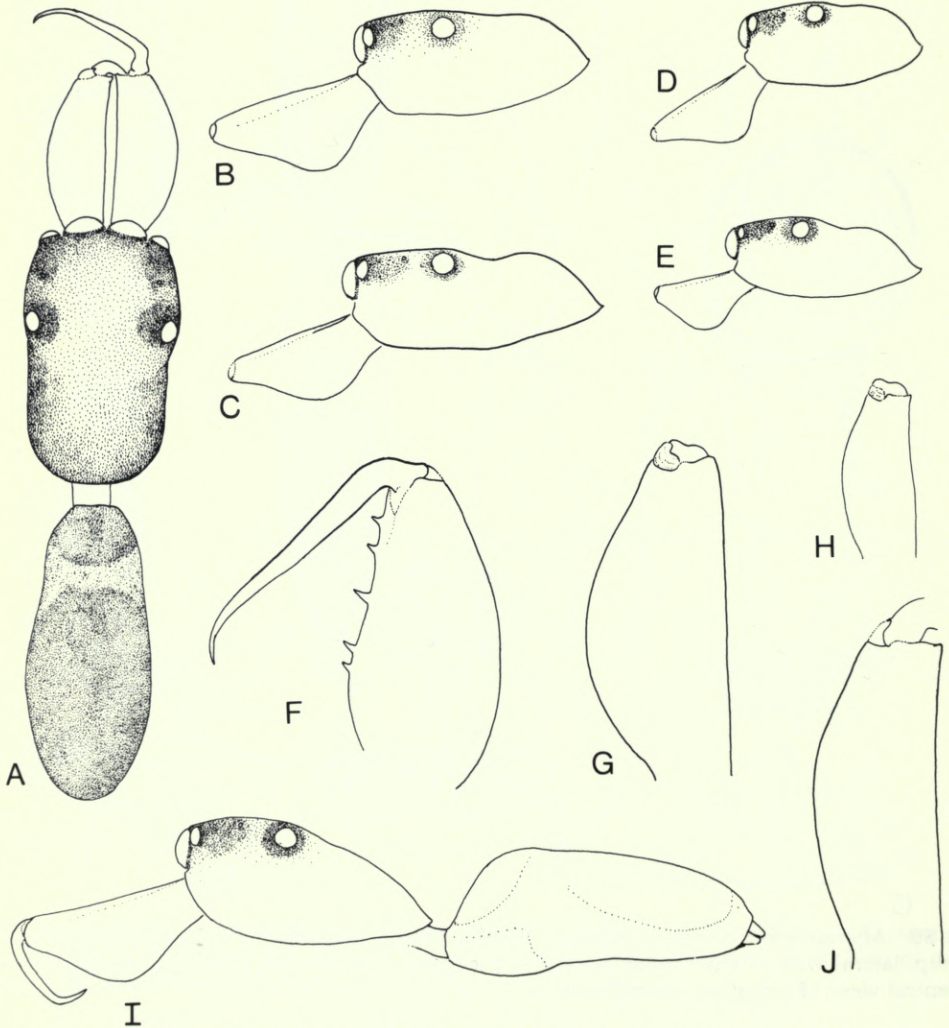

Fig. 81 *Myrmarachne simplexella* Roewer. Lectotype ♂: (A) dorsal view; (F) chelicera, ventral view; (I) lateral view; (J) chelicera, dorsal view. ♂ carapaces showing variation in shape (drawn to scale): (B, C, D) Antongil specimens; (E) from Massif Andringitra. ♂ chelicera showing size variation (drawn to scale): (G) Antongil specimen; (H) from Massif Andringitra.



a median keel. *Sternum*: elongate; orange-brown. *Abdomen* (Fig. 81A-I): yellowish brown with blackish mottling and dark reddish brown scuta; sparsely clothed with yellowish hairs with light orange-brown hairs on the scuta. *Legs*: femora I slightly enlarged; Legs I-II yellow-brown with metatarsi, tarsi proximally and sides of patellae and femora brownish. Legs III-IV generally brownish with lighter tarsi. Ventral spination of legs I: metatarsi 2-2, tibiae usually 2-2-2-2-2, patellae 1 or 2. *Palp* (Fig. 82A-E): rather variable particularly the shape of the flange and the thickness of the embolus.

*Dimensions*: total length 4.4-6.4 mm, carapace length 2.0-2.9 mm. *Ratios*: AM : AL : PM : PL: 12 : 7 : 2 : 7, AL-PM-PL: 10-9; a: 1.02-1.05, b: 1.02-1.07, c: 0.42-0.47, d: 0.42-0.62, e: 0.67-1.06 (9 ♂ examined).

This species shows considerable variation in the shape of the carapace (Fig. 81B-E, I) and palp structure (Fig. 82C-E). On the basis of the specimens at hand it is a problem of deciding if the sample consists of one variable species or a group of closely related ones. In view of the fact that the variation is inconsistent I propose to regard *M. simplexella* as a variable species until additional specimens can be examined.

**BIOLOGY.** Unknown.

**DISTRIBUTION.** Madagascar.

**MATERIAL EXAMINED.** Lectotype ♂ and paralectotype ♂, data as in synonymy. **MADAGASCAR:** Massif Andringitra, Mahasoa, 2100 m, 3 ♂, x.1971 (*B. Ranson*, MT 142833); Mt Ambohisanga, 1 ♂, i.1951 (*A. Pierrard*, MT 142912) (MRAC, Tervuren). Antongil, 3 ♂ (*A. Mocqueries*) (MNHN, Paris).

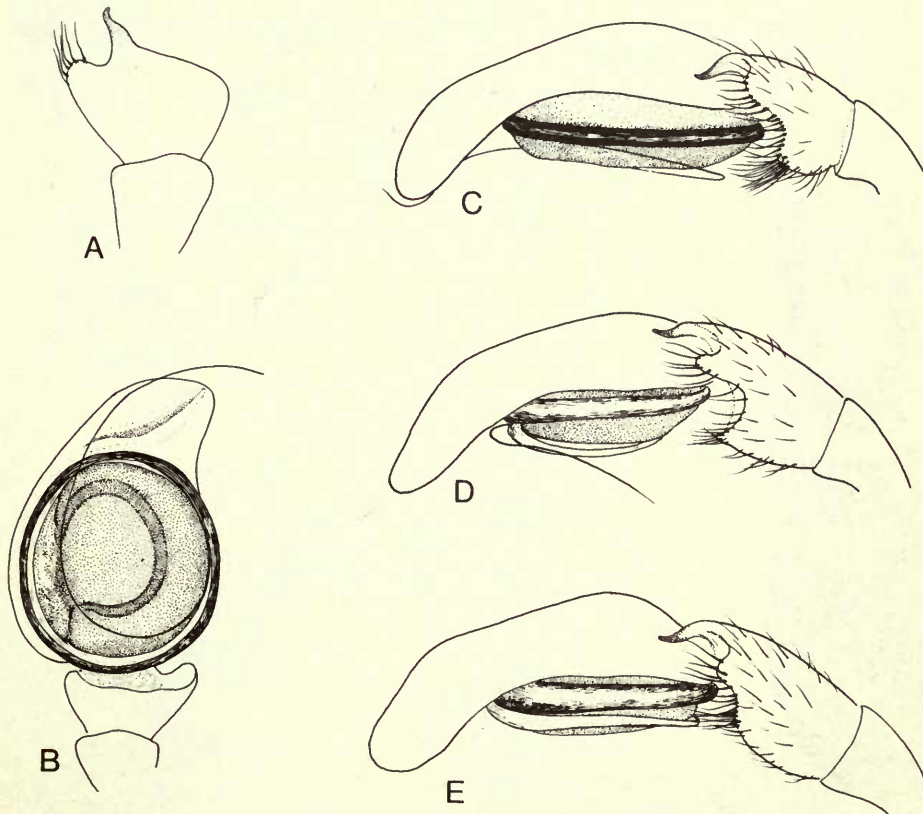

**Fig. 82** *Myrmarachne simplexella* Roewer. Lectotype ♂: (A) palpal tibia, dorsal view; (B) palp, ventral view; (C) palp, lateral view. Males from Antongil showing variation in flange shape and embolus thickness: (D) palp, lateral view; (E) palp, lateral view.



Species Sola

*Myrmarachne ransoni* sp. n.

(Fig. 83A-E)

DIAGNOSIS. *M. ransoni* is a distinctive species readily distinguished from all other Ethiopian *Myrmarachne* by the very large spermathecae (Fig. 83C, E).

MALE. Unknown.

FEMALE. *Carapace* (Fig. 83A, D): finely punctured-reticulate grading to finely rugulose in eye region; reddish orange, shiny. *Eyes*: subcontiguous with apices procurved, sparsely fringed with whitish hairs. *Clypeus*: sparsely fringed with light brown hairs. *Chelicerae*: rugose; orange-brown; promargin with 5 teeth, retromargin with 6. *Maxillae and Labium*: light orange-brown tinged with blackish. *Sternum* (Fig. 83B): light orange-brown tinged with black. *Abdomen* (Fig. 83A): whitish yellow with somewhat diffused grey-black pigment (poorly preserved). *Legs*: legs I with tarsi, trochanters and coxae light yellowish; metatarsi dark orange-brown; other segments orange-brown but venter of femora whitish yellow distally. Legs II as I but metatarsi orange-brown and femora whitish yellow. Legs III light orange-brown. Legs IV orange-brown but tarsi, tibiae distally, sides and venter of patellae, trochanters, dorsam and venter of coxae whitish yellow. Ventral spination of legs I: metatarsi 2-2, tibiae 2-2-2-2, patellae 1. *Epigyne* (Fig. 83C, E).

*Dimensions*: total length 5.7 mm, carapace length 2.14 mm. *Ratios*: AM : AL : PM : PL: 10 : 5.6 : 1.5 : 6, AL-PM-PL: 8.5-5; a: 1.03, b: 1.10, c: 0.45, e: 0.85 (1 ♀ examined).

BIOLOGY. Unknown.

DISTRIBUTION. Madagascar.

MATERIAL EXAMINED. Holotype ♀, MADAGASCAR, Massif Andringitra, Mahasoa, 2100 m, x.1971 (*B. Ranson*, MT 142905) (MRAC, Tervuren).

ETYMOLOGY. This species is named after the collector Mr B. Ranson.

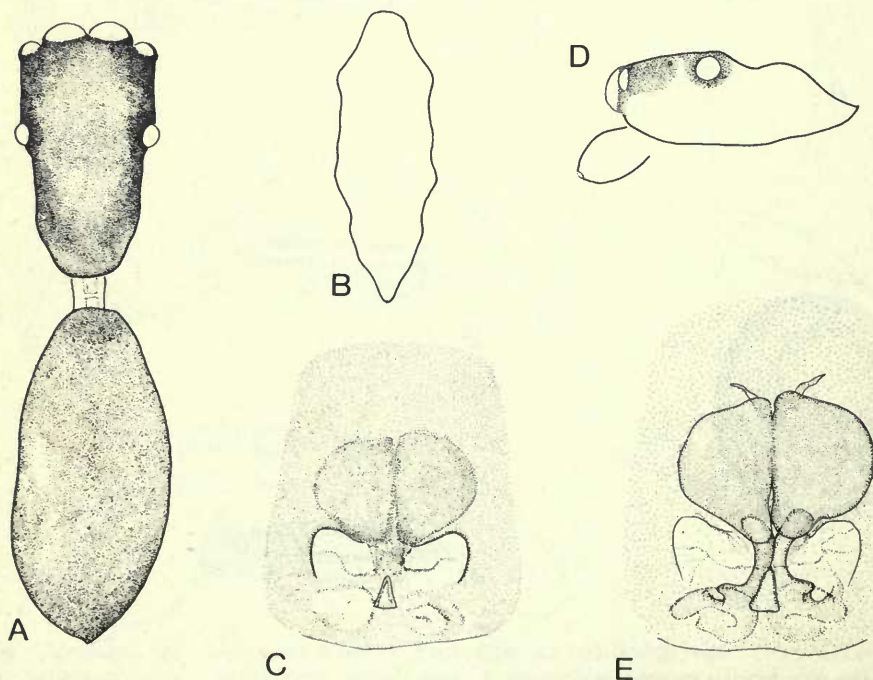

Fig. 83 *Myrmarachne ransoni* sp. n. Holotype ♀: (A) dorsal view; (B) sternum; (C) epigyne, ventral view; (D) carapace, lateral view; (E) vulva, ventral view.

Species Sola

*Myrmarachne diegoensis* sp. n.

(Fig. 84A-G)

DIAGNOSIS. *M. diegoensis* is a species of uncertain affinities but the presence of small stout setae just below the base of the tibial apophysis (Fig. 84E, G) is diagnostic.

FEMALE. Unknown.

MALE. *Carapace* (Fig. 84A, F): eye region finely punctured-reticulate, thoracic part finely papillate; light orange or orange-brown with yellowish guanin in eye region. *Eyes*: anteriors subcontiguous with apices procurved, fringed with white hairs. *Clypeus*: sparsely white haired. *Chelicerae* (Fig. 84B, C): rugulose with furrows; yellowish orange, shiny with dark orange

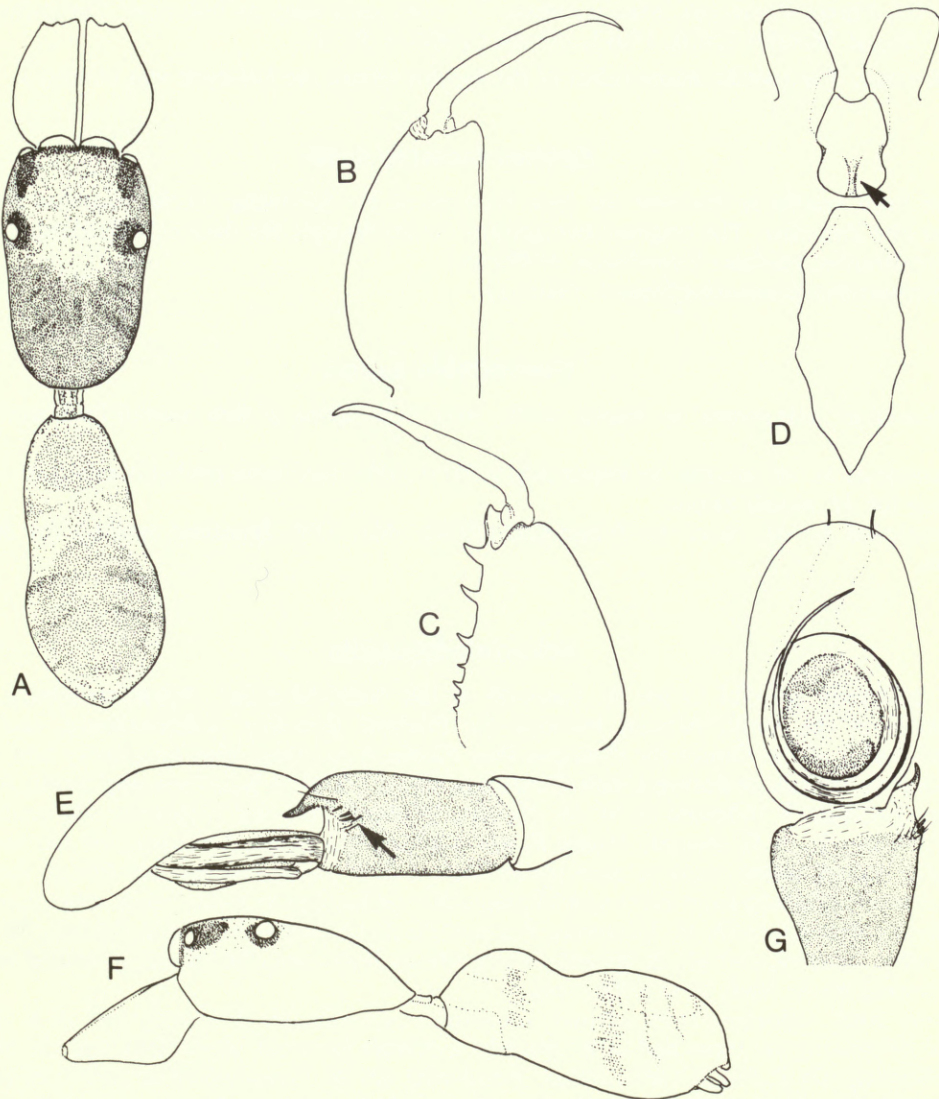

Fig. 84 *Myrmarachne diegoensis* sp. n. Holotype ♂: (A) dorsal view; (B) chelicera, dorsal view; (C) chelicera ventral view; (D) maxillae, labium and sternum; (E) palp, lateral view; (F) lateral view; (G) palp, ventral view.



lateral keels; fang apophysis and retromarginal teeth lacking. *Maxillae*: light orange. *Labium*: light orange with a median keel. *Sternum* (Fig. 84D): pale yellow. *Abdomen* (Fig. 84A, F): whitish yellow with shiny light orange scuta and greyish transverse bands; ventral scuta obscure, light orange; sparsely covered with fine, light orange hairs. *Legs*: light yellowish orange except for metatarsi and tibiae I which are darker. Ventral spination of legs I: metatarsi 2-2, tibiae 2-2-2-2, patellae 1. *Palp* (Fig. 84E, G): the number and arrangement of stout setae below the base of the tibial apophysis are variable and they are usually mixed with scattered hairs.

*Dimensions*: total length 5.1-6.3 mm, carapace length 2.2-2.9 mm. *Ratios*: AM : AL : PM : PL : 11 : 6 : 2 : 6.5, AL-PM-PL: 9-9; a: 0.94-1.0, b: 0.97-1.0, c: 0.41-0.44, d: 0.47-0.58, e: 0.92-1.03 (10♂ examined).

BIOLOGY. Unknown.

DISTRIBUTION. Madagascar.

MATERIAL EXAMINED. Holotype ♂, MADAGASCAR, Diego-Suarez, (*Ch. Alluaud*, MNHN 11012) (MNHN, Paris). Paratypes. MADAGASCAR: 7♂ with same data as holotype; Diego-Suarez, 3♂ (*Ch. Alluaud*, MNHN 12609, 11012, 175.58) (MNHN, Paris).

ETYMOLOGY. The specific name refers to the locality where the holotype was collected.

### Species incertae sedis

I have been unable to examine the type material of the following species recorded from East Africa and Zanzibar. The original descriptions are inadequate for their certain identity.

*Myrmarachne exultans* Caporiacco, 1949 (♀).

*Myrmarachne sansibarica* Strand, 1910 (♂).

### Unavailable names

Mentioned as '*Iola covani*' by Simon (1901 : 503). Misspelling of *Iola cowanii* Peckham & Peckham.

Mentioned as '*M. mexilis*' by Prószyński (1971b : 439). Vial label probably mis-read, incorrect spelling for *M. nexilis* Simon.

Mentioned as '*M. vieteti*' by Prószyński (1971b : 441, 519). Incorrect spelling for *M. viettei* Kraus.

### Acknowledgements

I am especially grateful to Mr B. Lamoral of the Natal Museum, Pietermaritzburg, Mr G. Newlands of the South African Institute for Medical Research, Johannesburg, and Mr A. Russell-Smith of the Centre for Overseas Pest Research for their kind hospitality and facilities extended to the author during a visit (February-March 1976) to Botswana and South Africa.

I am particularly indebted to M. M. Hubert, Muséum National d'Histoire Naturelle, Paris, and Professor P. L. G. Benoit, Musée Royal d'Afrique Centrale, Tervuren, for the hospitality extended during recent visits to their institutions. I wish to thank Professor Benoit for sorting out a crucial collection from Zaire and Madagascar and helping to locate many obscure localities.

I am also grateful to Dr M. Edmunds, Preston, Dr A. de Barros Machado, Lisbon, Mr & Mrs J. Murphy, London, and Mr A. Russell-Smith, Maun, Botswana, for helping in several ways and for allowing me to study their collections.

Many other colleagues from various institutions (see also list of depositories on p. 3) kindly helped by making the types and other material available for study or in other ways in particular the following: Dr P. Fox (COPR, Maun, Botswana), Dr M. Grasshoff (Frankfurt), Professor T. Kronstedt (Stockholm), Ms J. Lee (Legon, Ghana), J. C. Ledroux (Avignon, France), Professor H. W. Levi (Cambridge, U.S.A.), Dr J. D. Majer (South Bently, Australia), Mr T. J. Perfect (COPR, Ibadan, Nigeria) for specially taking the photographs for Pl. 6, Dr G. Rack (Hamburg),



Professor O. W. Richards (London), Mr E. Watt (Maun, Botswana), Mr B. Bolton (BMNH, London) who identified ants and provided the photograph for Pl. 7, Dr Z. Boucek (CIE, London) for helpful discussions on microsculpture; Mr M. C. Day (BMNH, London) who identified wasp larvae and supplied data on spider hunting wasps; Miss E. E. Fejer (BMNH, London) for linguistic help and finally Mr K. H. Hyatt (BMNH, London and Mr D. Macfarlane (CIE, London) for reading the manuscript and linguistic help.

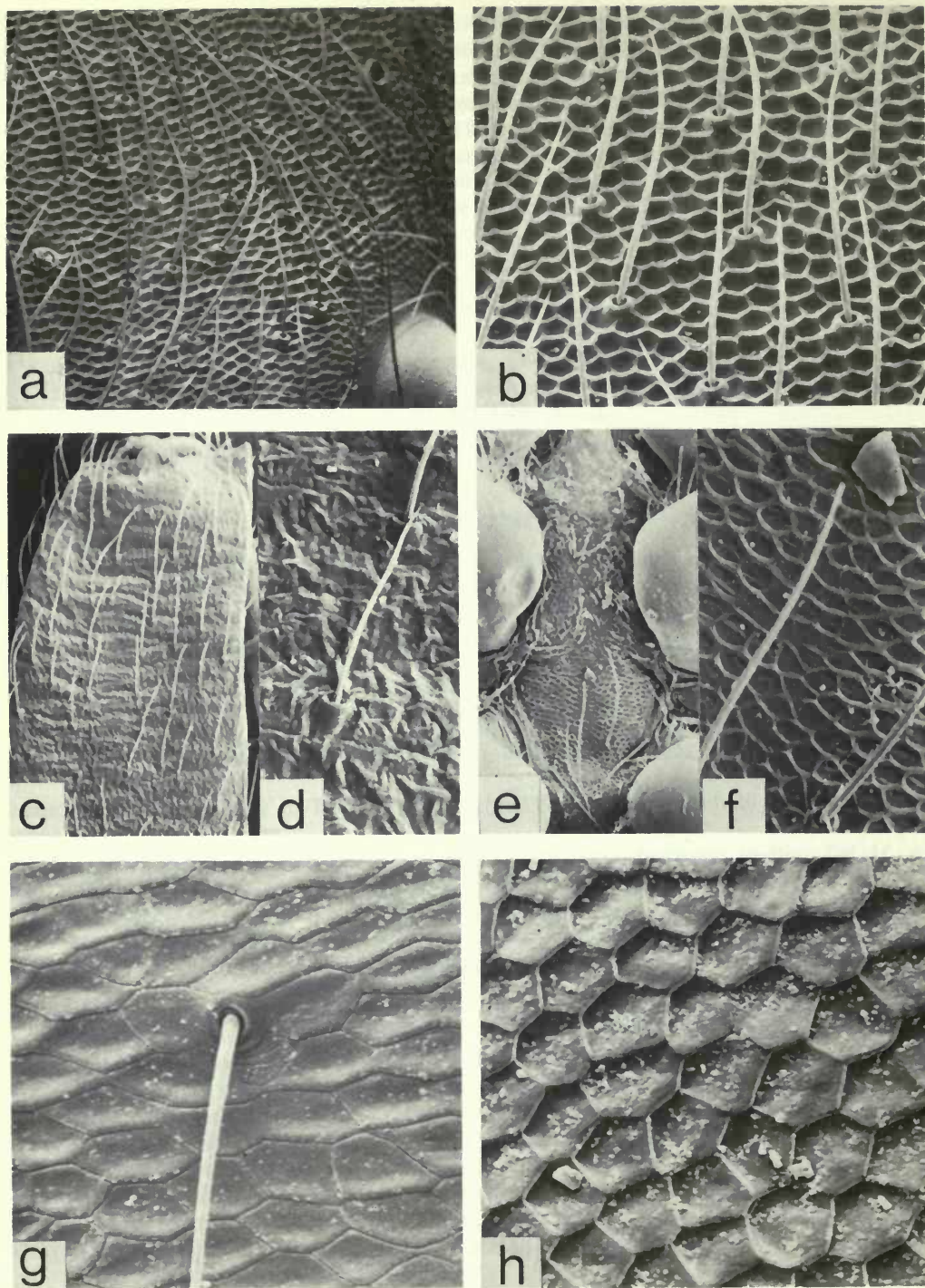

**Plate 1** Scanning electron micrographs of cuticle microsculpture. (a, b, c, d) *Myrmarachne marshalli* Peckham & Peckham. ♂: (a, b) posterior part of eye region, punctured-reticulate between piliferous papillae,  $\times 50$  and  $\times 500$ ; (c, d) chelicera in dorsal view, rugulose with irregular cross furrows and scattered piliferous papillae,  $\times 100$  and  $\times 500$ . (e, f) *Myrmarachne collarti* Roewer. ♂: sternum, raised reticulate,  $\times 100$  and  $\times 500$ . (g) *Belippo ibadan* sp. n. ♂: dorsal surface of abdomen, alutaceous,  $\times 1000$ . (h) *Myrmarachne foenisex* Simon. ♂: cephalic region, scaly reticulate,  $\times 1000$ .



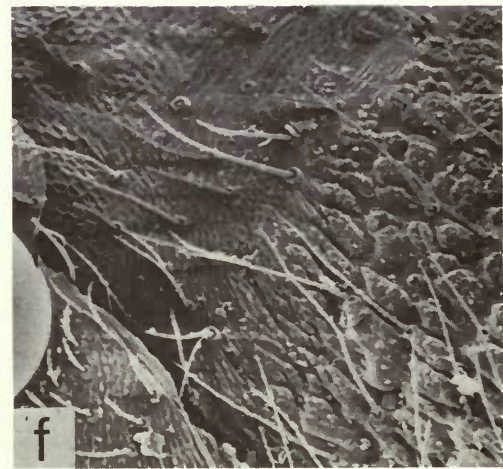
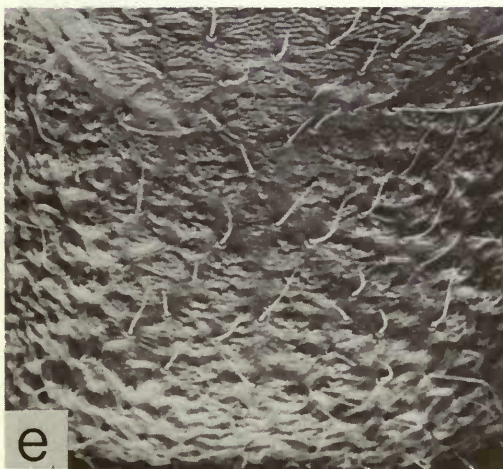
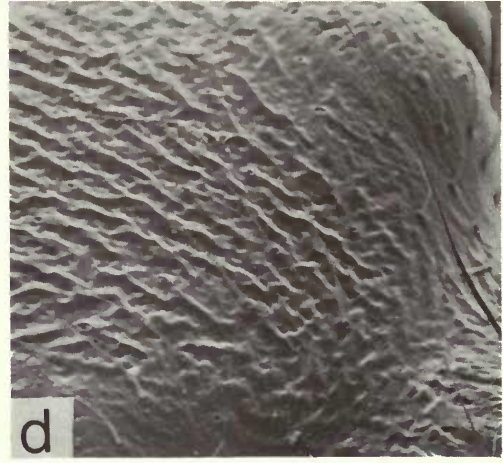
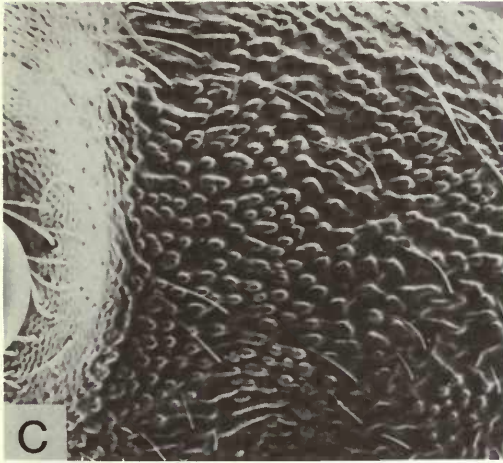
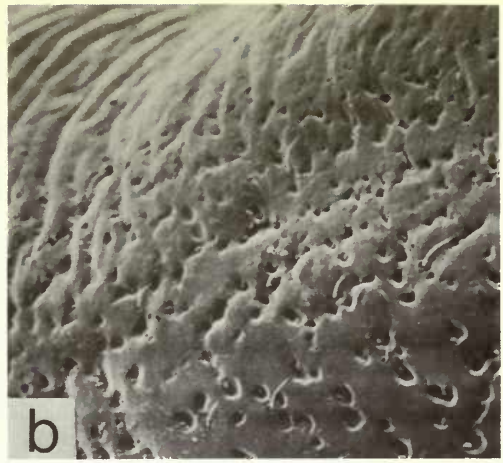
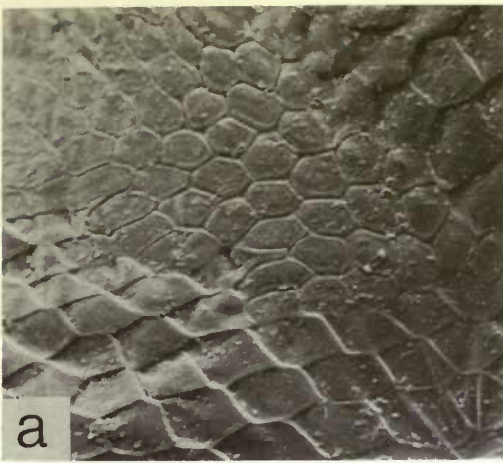

**Plate 2** Scanning electron micrographs of cuticle microsculpture. (a) *Myrmarachne foenisex* Simon. ♂: cephalic region, scaly reticulate to engraved reticulate to scaly reticulate,  $\times 1000$ . (b) *Myrmarachne eumenes* (Simon). ♂: thoracic part, smooth between irregular punctures with irregular furrows around posterior margin,  $\times 200$ . (c) *Belippo cygniformis* sp. n. ♂: thoracic part, densely papillate with irregular ripples,  $\times 200$ . (d) *Belippo ibadan* sp. n. ♂: eye region between PL, rippled,  $\times 200$ . (e, f) *Myrmarachne eugenei* nom. n. ♀: thoracic part and posterior of head region, punctured-reticulate to irregularly tumulose with scattered piliferous papillae,  $\times 100$  and  $\times 200$ .



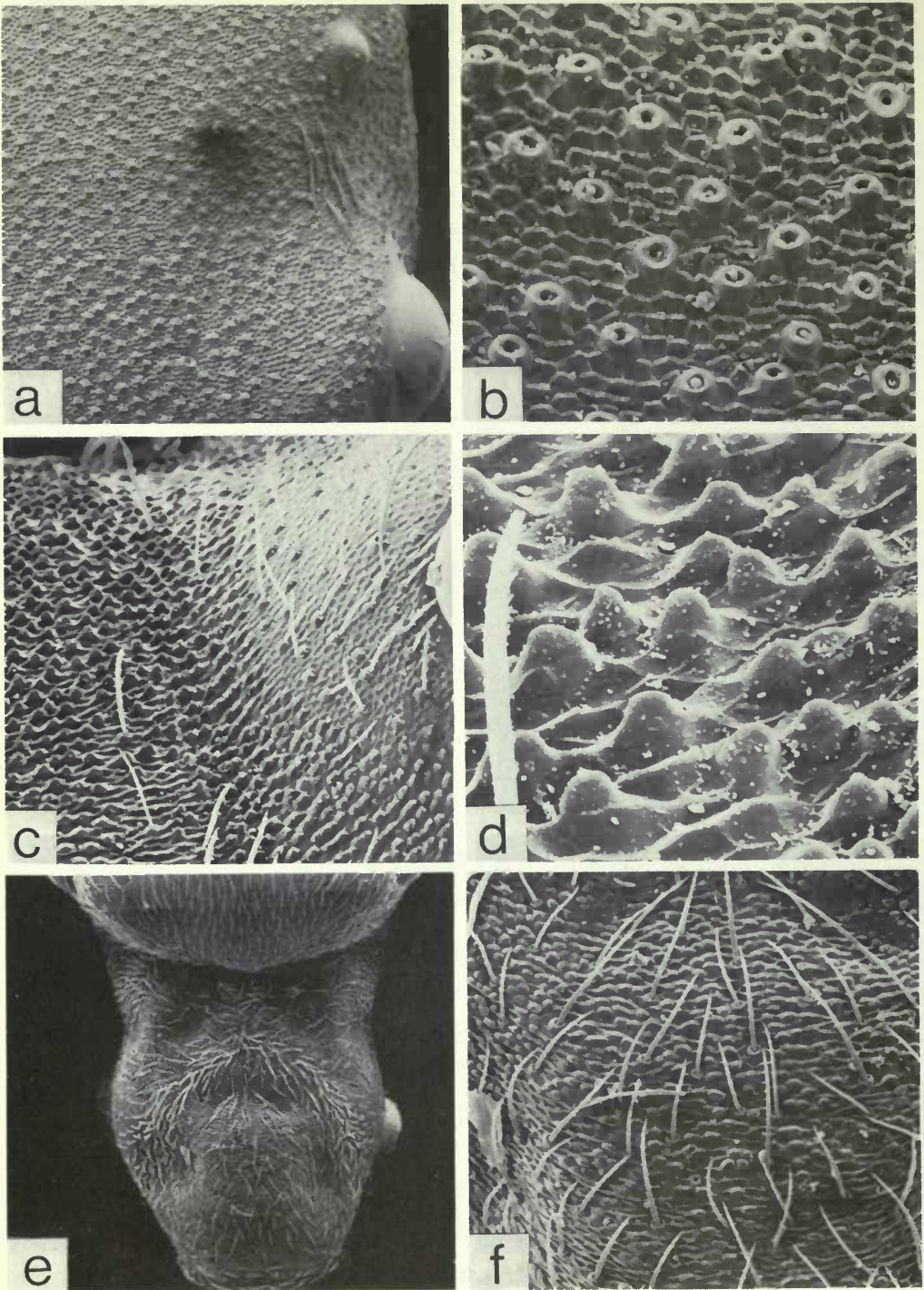

**Plate 3** Scanning electron micrographs of cuticle microsculpture. (a, b) *Myrmarachne globosa* sp. n. ♀: cephalic region in dorsal view, punctured-reticulate between moderately dense piliferous papillae,  $\times 100$  and  $\times 500$ . (c, d) *Myrmarachne kilifi* sp. n. ♀: thoracic part in lateral view, irregularly punctured-reticulate between dense papillae and scattered piliferous papillae,  $\times 200$  and  $\times 1000$ . (e, f) *Myrmarachne foenisex* Simon. ♂: thoracic part and posterior of head region, irregularly punctured-reticulate between dense papillae and piliferous papillae,  $\times 50$  and  $\times 200$ .



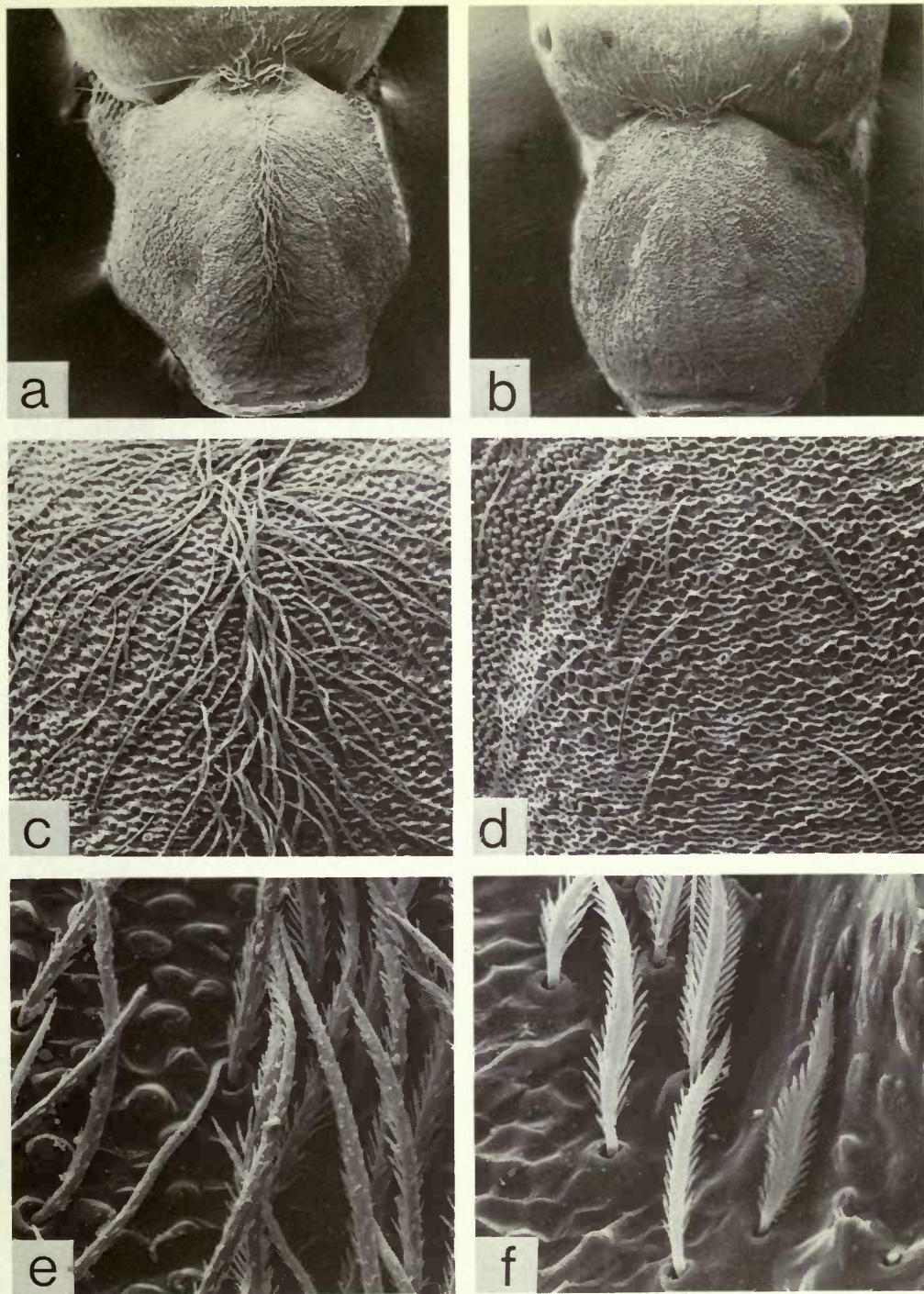

**Plate 4** Scanning electron micrographs of cuticle microsculpture and setae. (a, c, e) *Myrmarachne marshalli* Peckham & Peckham. ♂: (a) thoracic part showing longitudinal fringe,  $\times 100$ ; (c) thoracic part with fringe, irregularly punctured-reticulate with dense, irregular patterns of papillae and scattered piliferous papillae,  $\times 200$ ; (e) setae in longitudinal fringe,  $\times 2000$ . (b, d) *Myrmarachne legon* sp. n. ♂: (b) thoracic part showing absence of longitudinal fringe,  $\times 100$ ; (d) thoracic part, similar to *marshalli* but pattern of piliferous papillae less dense,  $\times 200$ . (f) *Myrmarachne legon* sp. n. ♂: setae in postocular constriction,  $\times 2000$ .





**Plate 5** Scanning electron micrographs of *Myrmarachne dundoensis* sp. n., showing variation in apophysis and flange development. (a) ♂ from Dundo, apophysis more slender, flange well developed,  $\times 500$ . (b) ♂ from same locality as a, apophysis less slender, flange poorly developed,  $\times 500$ .





Plate 6 (a, b) Nests of *Oecophylla longinoda* (Lat.).



Plate 7 Opened nest of *Oecophylla* sp. (Photographer unknown.)



## References

- Bacelar, A.** 1953. Algumas Aranhas de Mocambique (Colecao de Rose Monteiro). *Archos Mus. Bocage* 24 : 1-19.
- Berland, L. & Millot, J.** 1941. Les araignées de l'Afrique occidentale française. I. Les Salticides. *Mém. Mus. Hist. nat. Paris* n.s. 12 : 297-424.
- Bhattacharya, G. C.** 1939. On the moulting and metamorphosis of *Myrmarachne platealeoides* Camb. *Trans. Bose Res. Inst.* 12 : 103-114.
- Blackwall, J.** 1865. Descriptions of recently discovered spiders collected in the Cape de Verde Islands by John Gray, Esq. *Ann. Mag. nat. Hist.* (3) 16 : 80-101.
- Bonnet, P.** 1945-61. *Bibliographia Araneorum* 3 vols. Imprimerie Douladoure, Toulouse.
- Brignoli, P. M.** 1966. I ragni mirmecomorfi. *Rc. Ist. lomb. Sci. Lett.* 100 : 63-91.
- Caporiacco, L. di** 1933. Araneidi. Spedizione scientifica all'oasi di Cufra (Marzo-Luglic, 1931). *Annali Mus. civ. Stor. nat. Giacomo Doria* 56 : 311-340.
- 1940. Aracnidi raccolti nella regione dei Laghi Etiopici della Fossa Galla. *Atti R. Accad. Ital. Memorie* 11 (18) : 767-873.
- 1947. Arachnida Africae Orientalis, a dominibus Kittenberger, Kovács et Bornemisza Lecta in Museo Nationali Hungarico servata. *Annls hist.-nat. Mus. natn. hung.* 40 (3) : 97-257.
- 1949. Aracnidi della Colonia del Kenya raccolti da Toschi & Meneghetti negli anni 1944-1946. *Comm. Pont. Acad. Scient.* 13 (6) : 309-492.
- Collart, A.** 1929a. Quelques observations sur une araignée mimétique. *Revue Zool. Bot. afr.* 18 (2) : 147-161.
- 1929b. Quelques notes sur les *Myrmarachne* araignées oecophylliformes. *Bull. Cerc. zool. congol.* 5 : 117-118.
- 1941. Notes complémentaires sur *Myrmarachne foenisex* Simon, araignée myrmécomorpe du Congo Belge. *Bull. Mus. r. Hist. nat. Belg.* 17 : 1-11.
- Denis, J.** 1966. Les araignées du Fezzân. *Bull. Soc. Hist. nat. Afr. Nord.* 55 : 103-144.
- Eady, R. D.** 1968. Some illustrations of microsculpture in the Hymenoptera. *Proc. R. ent. Soc. Lond.* 43 (4-6) : 66-72.
- Edmunds, M.** 1974. *Defence in animals*. Harlow.
- Fage, L.** 1927. Araneida. In Monod, Th., Contribution à l'étude de la faune du Cameroun. *Faune Colon.* fr. 1 : 635-636.
- Galiano, M. E.** 1965. Salticidae (Araneae) formiciformes. IV. Revision del genero *Sarinda* Peckham, 1892. *Revta Mus. argent. Cienc. nat. Bernardino Rivadavia Inst. nac. Invest. Cienc. nat.* 1 (4) : 267-312.
- 1969. Salticidae (Araneae) formiciformes. XII. El genero *Myrmarachne* Mac Leay, 1839, en America. *Revta Mus. argent. Cienc. nat. Bernardino Rivadavia Inst. nac. Invest. Cienc. nat.* 3 (2) : 107-148.
- 1974. Salticidae (Araneae) formiciformes. XIV. Descripcion de dos nuevas especies del genero *Myrmarachne* Macleay, 1839. *Physis B. Aires* 33 (87) : 221-230.
- Giltay, L.** 1929. Notes arachnologiques africaines. *Revue Zool. Bot. afr.* 18 (1) : 23-27.
- Hahn, C. W.** 1831. *Die Arachniden*. Bd 1, 129 pp. Nürnberg.
- Hingston, R. W. G.** 1927. Field observations on spider mimics. *Proc. zool. Soc. Lond.* 56 : 841-858.
- Jackowska, B. & Prószyński, J.** 1975. In search of the natural system of ant-like Salticidae. *C. R. 6th Congr. intern. Arachn. Amsterdam IV.* 39-43.
- Kaston, B. J.** 1970. Comparative biology of American black widow spiders. *Trans. S. Diego Soc. nat. Hist.* 16 (3) : 33-82.
- Kraus, O.** 1960. Mission du muséum dans les îles du golfe de Guinée. *Revue fr. Ent.* 27 (1) : 92-100.
- Lawrence, R. F.** 1938. A collection of spiders from Natal and Zululand. *Ann. Natal Mus.* 8 (3) : 455-524.
- 1941. A contribution to the araneid fauna of Natal and Zululand. *Ann. Natal Mus.* 10 (1) : 141-190.
- Lessert, R. de** 1925a. Araignées du Kilimandjaro et du Mérou. *Revue suisse Zool.* 31 (13) : 429-528.
- 1925b. Araignées du Sud de l'Afrique. *Revue suisse Zool.* 32 (21) : 323-365.
- 1942. Araignées myrmécomorphes du Congo Belge. *Revue suisse Zool.* 49 (2) : 7-12.
- Macleay, W. S.** 1838. On some new forms of arachnida. *Ann. nat. Hist.* 2 (7) : 1-14.
- Marson, J. E.** 1947. The ant mimic *Myrmarachne platealeoides*. *Jl E. Africa nat. Hist. Soc.* 19 : 62-63.
- & **Carpenter, G. D. H.** 1946. Observations on the ant-mimicking spider *Myrmarachne platealeoides* Cambr, in India. *Entomologist's mon. Mag.* 82 : 52-53.
- Mathew, A. P.** 1934. The life history of the spider *Myrmarachne platealeoides* (Cambr). *J. Bombay nat. Hist. Soc.* 37 (2) : 369-374.
- 1940. A study of the courting habits of *Myrmarachne platealeoides* (Cambr) - a spider mimic of the Indian red-ant *Oecophylla smaragdina*. *J. Bombay nat. Hist. Soc.* 42 (1) : 171-180.



- 1954. Observations on the habits of the two spider mimics of the red ant, *Oecophylla smaragdina* (Fabr). *J. Bombay nat. Hist. Soc.* **52** (1–2) : 249–263.
- Narayan, K.** 1915. Notes on ant-like spiders of the family Attidae in the collections of the Indian Museum. *Rec. Indian Mus.* **11** : 393–406.
- Peckham, G. W.** 1889. Protective resemblances in spiders. *Occ. Pap. Wis. nat. Hist. Soc.* **1** (2) : 61–113.
- & **Peckham, E. G.** 1892. Ant-like spiders of the family Attidae. *Occ. Pap. Wis. nat. Hist. Soc.* **2** (1) : 1–83.
- — 1895. Notes on the habits of *Trypoxyllon rubrocinctum* and *Trypoxyllon albopilosum*. *Psyche Camb.* 303–306.
- — 1903. New species of the family Attidae from South Africa, with notes on the distribution of the genera found in the Ethiopian region. *Trans. Wis. Acad. Sci. Arts Lett.* **14** : 173–278.
- Petrunkévitch, A.** 1928. Systema Araneorum. *Trans. Conn. Acad. Arts Sci.* **29** : 1–270.
- Pickard-Cambridge, O.** 1869. Descriptions and sketches of some new species of Araneida, with characters of a new genus. *Ann. Mag. nat. Hist.* (4) **3** : 52–74.
- Pocock, R. I.** 1909. Mimicry in spiders. *J. Linn. Soc.* **30** : 256–270.
- Prószyński, J.** 1971a. Notes on systematics of Salticidae (Arachnida Aranei). 1–6. *Annls zool. Warsz.* **28** : 227–255.
- 1971b. Catalogue of Salticidae (Aranei) specimens kept in major collections of the world. *Annls zool. Warsz.* **28** : 367–519.
- 1971c. Problems of classification of Salticidae (Aranei). *Proc. 5th Congr. intern. Arachn. Bruno* 213–220.
- Reiskind, J.** 1970. Multiple mimetic forms in an ant-mimicking clubionid spider. *Science* **169** : 587–588.
- & **Levi, H. W.** 1967. *Anatea*, an ant-mimicking theridiid spider from New Caledonia (Araneae: Theridiidae). *Psyche, Camb.* **74** (1) : 20–23.
- Rettenmeyer, C. W.** 1970. Insect mimicry. *A. Rev. Ent.* **15** : 43–74.
- Richards, O. W.** 1947. Observations on *Trypoxylon placidum* Cam. (Hym., Sphecoidea). *Entomologist's mon. Mag.* **83** : 53.
- Roewer, C. F.** 1942. Opiliones, Pedipalpi und Araneae von Fernando Poo. *Veröff. Deutsch. Kolon. Uebersee-Mus. Bremen* **3** (3) : 244–258.
- 1951. Neue namen einiger Araneen-Arten. *Abh. naturw. Ver. Bremen* **32** (3) : 437–456.
- 1954. *Katalog der Araneae*. 2 Abt. B: 925–1290. Institut Royal des Sciences Naturelles de Belgique, Bruxelles.
- 1965. Die Lyssomanidae und Salticidae – Pluridentati der Äthiopischen Region (Araneae). *Annls Mus. r. Afr. cent.* No. 139 : 1–86.
- Simon, E.** 1882. Étude sur les arachnides de l'Yemen méridional. *Annali Mus. civ. Stor. nat. Giacomo Doria* **18** : 207–260.
- 1886. Études arachnologiques. 18e Mémoire XXVI Matériaux pour servir à la faune des arachnides du Senegal. Appendix – Description de plusieurs espèces africaines nouvelles. *Annls Soc. ent. Fr.* **5** (6) : 345–396.
- 1887. Études arachnologiques. 19e Mémoire XXVII Arachnides recueillis à Assinie (Afrique occidentale) par MM M. Chaper et C. Alluaud. *Annls Soc. ent. Fr.* **7** (6) : 261–276.
- 1890. Étude sur les arachnides de l'Yemen. *Annls Soc. ent. Fr.* **10** (6) : 77–124.
- 1900. Descriptions d'arachnides nouveaux de la famille des Attidae. *Annls Soc. ent. Belg.* **44** : 381–407.
- 1901. *Histoire Naturelle des Araignées*. **2** (3) Paris: 381–668.
- 1903. *Histoire Naturelle des Araignées*. **2** (4) Paris: 669–1080.
- 1910. Arachnides recueillis par L. Fea sur la Côte occidentale d'Afrique. 2e partie. *Annali Mus. civ. Stor. nat. Giacomo Doria* **4** (3) (= 44) : 335–449.
- Strand, E.** 1907. Diagnosen neuer spinnen aus Madagascar und Sansibar. *Zool. Anz.* **31** (23) : 725–748.
- 1910. Zwei neue exotische *Myrmarachne* – Arten. *Int. ent. Z.* **4** : 13–15.
- 1929. Zoological and palaeontological nomenclatorial notes. *Latv. Univ. Rak.* **20** (29) : 1–29.
- Szombathy, K.** 1913. Adatok a hangyantánzó ugrópokok pontosabb ismeretehez. *Allatt. Közl.* **12** : 22–40.
- 1915. Attides nouveaux appartenant aux collections du Musée National Hongrois. *Annls hist.-nat. Mus. natn. hung.* **13** : 465–490.
- Thorell, T.** 1877. Studi sui Ragni Malesi e Papuani. I. Ragni di Selebes raccolti nel 1874 dal Dott. O. Beccari. *Annali Mus. civ. Stor. nat. Giacomo Doria* **10** : 341–634.
- Walker, F.** 1854. *List of the specimens of lepidopterous insects in the collection of the British Museum*. London, part 2.
- Wanless, F. R. & Clark, D. J.** 1975. On a collection of spiders of the family Salticidae from the Ivory Coast. *Rev. Zool. afr.* **89** (2) : 273–296.

## Index

Names printed in italics refer to synonyms and other unavailable names; numbers in bold face refer to figures in the text and numbers in italics refer to the main entry.

- abimva*, Myrmarachne, 51, 52  
acvapimensis, Camponotus, 21, 71, 72  
*akermani*, Myrmarachne, **65**, **66**, 67  
albosetosa, Myrmarachne, 24, 106, **107**, **108**, **108**  
ambigua, Mesoponera, 18, 21  
andrewi, Myrmarachne, 25, 26, 98, **103**, **104**, **105**  
andringitra, Myrmarachne, 26, 115, **117**, **118**,  
119, 121, 122  
anguina, Belippo, 5, 7, 9, 10  
*angusta*, Salticus, 109  
*angustiformis*, Myrmarachne, 109  
anthracina Tetraponera, 21  
Araneidae, 18  
*atra*, Myrmarachne, 51  
augusta, Myrmarachne, 24, 106, **109**, **110**, **111**  
*augustus*, Salticus, 73, 109
- bamakoi, Myrmarachne, 25, 69, **72**, 73, 82  
Belippo, 2, 4, 5, 7, 8, 9, 10, 18–21  
*benoiti*, Myrmarachne, 67  
bequaerti, Anochetus, 18, 21  
*Bizone*, 18, 20  
*Bizonella*, 18  
*bredoi*, Myrmarachne, 67  
*burgeoni*, Myrmarachne, 67, **68**
- cahni*, Myrmarachne, **54**, 55  
calcarata, Belippo, 7, **11**, **12**, 13, 21  
*calcarata*, Myrmarachne, 11  
Camponotus, 21, 69, 84, 90  
*chelata*, Myrmarachne, 46  
Chrysilleae, 18  
Clubionidae, 18, 21  
collarti, Myrmarachne, 21, 24, **48**, 49, 128  
confusus, Myrmarachne, 10, 24, 46, **47**, 49  
constricta, Myrmarachne, 23  
*coppeti*, Myrmarachne, **49**, **50**, 51, **53**  
Cosmophasis, 18, 23, 54  
*cowani*, Myrmarachne, 73  
*cowanii*, *Iola*, 18, 73, 126  
*cowanii*, Myrmarachne, 25, 26, 73, **74**, **75**, 109  
*covani*, *Iola*, 126  
Crematogaster, 21, 71, 72, 93, 95, 97  
cygniformis, Belippo, 7, **15**, 16, 17, 129
- dartevellei*, Myrmarachne, 51  
depressa, Crematogaster, 18, 21  
diegoensis, Myrmarachne, 24, 106, **125**, **125**  
*diversicoxis*, Myrmarachne, 78  
*diversipes* var *tristis*, Myrmarachne, 64  
Dolichoderinae, 22  
dundoensis, Myrmarachne, 21, 25, 27, 73, 79,  
82, **83**, **84**, 132
- eidmani, Myrmarachne, 20, 24, 28, 29, **38**, 39  
electrica-group, 19, 23, 106, 114, **115**  
electrica, Myrmarachne, 24, 115, **118**, **119**  
*electricus*, Salticus, 118  
elongata, Myrmarachne, 20–29, 46, **49**, **50**, 50,  
**51**, 52, **53**, 55, 57, 59  
Emertonius, 19  
Enoplomischus, 18  
Eresidae, 18  
eugenei, Myrmarachne, 19, 24, 26, **115**, **116**,  
**117**, 129  
eumenes, Myrmarachne, 23, 26, **113**, **114**,  
**114**, 129  
*eumenes*, Salticus, 114  
evidens, Myrmarachne, 24, 42, **43**, **44**, 45, 46, 52  
exultans, Myrmarachne, 126
- faradjensis*, Myrmarachne, 51  
foenisex, Myrmarachne, 2, 20–24, 27, 55, **59**,  
60, **60**, 61, 62, 72, 128–130  
foreli, Myrmarachne, 21, 25, 27, 57, 79, 85, **85**  
formicaria-group, 20, 23, 29, 57, 73, 82, 85, 91,  
94  
formicaria, Myrmarachne, 73
- geminata*, Solenopsis, 21, 23  
giltayi, Myrmarachne, 20, 25, 28, 29, **34**, **35**,  
36, 37  
globosa, Myrmarachne, 26, **97**, **98**, 99, 100, 130  
Gnaphosidae, 18  
*gracilis*, Myrmarachne, 119  
*gracilis*, Salticus, 119
- Hemichalybion, 23  
*Hermosa*, 2, 18  
hesperia, Myrmarachne, 24, 42, **43**, **44**, **45**, 46,  
47, **49**, **50**, 51–53  
*hesperius*, Myrmarachne, 46, 50  
*hesperius*, Salticus, 46
- ibadan, Belippo, 7, **15**, 16, 17, 21, 128, 129  
ichneumon, Myrmarachne, 20, 24, 27, 29, 52,  
56, **57**, **58**, 84  
*ichneumon*, Salticus, 56  
inflatipalpis, Myrmarachne, 21, 26, 92, **94**, 95,  
**96**  
insulana, Myrmarachne, 21, 27, 39, 40, **41**, 42,  
46, 52  
*Iola*, 2, 18
- kasia*, Myrmarachne, 51  
kiboschensis, Myrmarachne, 20–22, 26, 27, 52,  
75, **77**, 78, 79, 80, 82

- kilifi, Myrmarachne, 25, 26, 98, **100**, **101**, 102, **102**, 130  
 kitale, Myrmarachne, 26, 27, 92, 94, **94**, 95, **96**
- Larrinae, 23  
 laurentina, Myrmarachne, 25, 26, 98, 99, **100**, **101**, **102**  
 Latroductus, 119  
 lawrencei, Myrmarachne, 25, 27, **28**, **29**, 30, **31**, 32, 33–35, 67  
 legon, Myrmarachne, 3, 21–29, 52, 64, 67, 69, **70**, **71**, 72, 131  
 leleupi, Myrmarachne, 26, 75, 79, 80, **80**, **81**, 82  
 lesserti-group, 19, 23, 106  
 lesserti, Myrmarachne, 24, 106, **107**, **108**  
 longinoda, Oecophylla, 21, 22, 61, 133  
 longipes, Anoplolepis, 21, 23  
 longiventris, Bizone, 18, 105, 106  
 longiventris, Bizonella, 105  
 longiventris, Myrmarachne, 20, 26, 98, **104**, **105**, 105, 106, 121  
 luachimo, Myrmarachne, 20, 25, 27–29, **34**, **35**, 36, 37, 37, 39  
 lulengana, Myrmarachne, 25, 27, 30, **31**, 32, **33**, **33**, 36, 37  
 lulengensis, Myrmarachne, 25, 52, **54**, 55, 57
- maerens*, Myrmarachne, 30  
 mahasoa, Myrmarachne, 26, 110, **111**, 112, 112  
 majungae, Myrmarachne, 98  
 majungana, Myrmarachne, 98  
 marshalli, Myrmarachne, 3, 21, 23, 25, 27, 29, 52, 64, 65, **66**, **67**, **68**, 69, 128, 131  
 melanocephala, Myrmarachne, 18  
 mexilis, Myrmarachne, 126  
 militaris, Myrmarachne, 24, 27, **28**, **29**, 30, **31**, 32–34  
 milloti, Belippo, 7, 11, 13, **14**  
 milloti, Myrmarachne, 13  
 Miscophini, 23  
 moto, Myrmarachne, 51, 52  
 mulungu, Myrmarachne, 67, **68**  
 mussungu, Myrmarachne, 20, 27, 40, **41**, 42  
 Myrmarachne, 2, 4, 5, 6, 8, 9, 18, 19–23, 66, 106, 109, 110, 115, 124  
 Myrmarachneae, 2  
 Myrmicinae, 18
- naro, Myrmarachne, 24, 42, **43**, 43, **44**, **45**, 46  
 natalensis, Tetraponera, 21, 86  
 natalica, Myrmarachne, 20, 27, 39, **40**  
 nexilis, Belippo, 7, 9, 9, 10, 48  
 nexilis, Myrmarachne, 9, 10, 46, 48, 126  
 nigeriensis, Myrmarachne, 21, 26, 27, 86, 88, **89**, **90**  
 nubilis-group, 19, 23, 110  
 nubilis, Myrmarachne, 26, 110, 111, **111**, **112**
- Oecophylla, 23, 134
- paucidentata*, Myrmarachne, **29**, 30  
 peckhami, Myrmarachne, 24, 26, 106, 115, 117, 118, 119, **120**, **121**  
 Pheidole, 13, 21  
 Pison, 23, 54, 63, 71  
 placidum, Trypoxylon, 23  
 Plagiolepis, 21, 23  
 plataleoides, Myrmarachne, 2, 20–23  
 Pompilidae, 23  
 Ponerinae, 18  
 Prenolepis, 21, 22  
 procera, Calotropis, 72  
 Pseudicus, 23, 54  
*punctata*, Myrmarachne, 39
- ransoni, Myrmarachne, 26, 124, **124**  
 rica, Castianeira, 23  
 richardsi, Myrmarachne, 23, 24, 60, 61, **62**, 91  
 riveti, Myrmarachne, **66**, 67, **68**  
*rufescens*, Emertonius, 115  
 rufescens, Myrmarachne, 115  
 rufisquei, Myrmarachne, 24, 55, **56**  
*rufula var tristis*, Salticus, 63  
 russellsmithi, Myrmarachne, 25, 92, 93, 94, 95
- Salticidae, 1, 2, 18  
 Salticus, 2  
 sansibarica, Myrmarachne, 126  
 Sarinda, 7  
 Sceliphron, 23  
*schoutedeni*, Myrmarachne, **28**, **29**, 30  
 sericeus Camponotus, 21, 88  
 Setaria, 79  
*simplex*, Myrmarachne, 122  
*simplex*, Salticus, 122  
 simplexella, Myrmarachne, 24, 111, 117, 121, **122**, **123**  
 smaragdina, Oecophylla, 21  
 Solenopsis, 21, 22  
 solitaria, Myrmarachne, 27, 75, **76**, 79, 80  
*solitarius*, Myrmarachne, 75, 108  
 Sphecidae, 23  
 Synemosyninae, 18
- Telamonia, 23, 54  
 Tetramorium, 21  
 Theridiidae, 18  
 Thomisidae, 18  
 tristis-group, 20, 23, 28, 29, 39, 60, 73, 82, 85, 91  
 tristis, Myrmarachne, 25, 27, 63, **63**, **64**, 66, 67, 69  
*tristis*, Salticus, 63  
 troglodytes, Odontomachus, 21, 79  
 Trypoxylon, 23  
 Trypoxyloninae, 23
- uelensis, Myrmarachne, 26, 75, 79, **80**, **81**, 82  
 uvira, Myrmarachne, 21, 22, 25, 27, 79, **86**, **87**, 88



vanessae, Myrmarachne, 25, 27, 62, 91, **91**  
vetitus-group, Camponotus, 21, 79  
*vietai*, Myrmarachne, 126  
viettei, Belippo, 7, 10, *10*, **11**  
*vietai*, Myrmarachne, 10, 126  
volatilis-group, 19, 23, 97, 102, 103, 106  
volatilis, *Hermosa*, 18, 98  
volatilis, Myrmarachne, 26, **97**, **98**, **98**, 99, 100

Zodariidae, 18