

GENERAL NOTE: This paper is intended for free dissemination at no charge. Please attribute the source correctly. This is a versioned paper, so that revisions and additions will be incorporated into subsequent versions dynamically. Please address all suggestions and corrections to the author. Copyright©2006,2007 by David Edwin Hill.

Use of location (relative direction and distance) information by jumping spiders (Araneae, Salticidae, *Phidippus*) during movement toward prey and other sighted objectives

Version 3 (November 26, 2007)

David E. Hill
213 Wild Horse Creek Drive, Simpsonville, South Carolina, 29680
platycryptus@yahoo.com

1. Preface

This paper presents information developed in the course of my graduate research at the University of Florida in the late 1970's. Most of this information has not been made available outside of my Ph.D. dissertation (Hill 1978b). Some results and ideas related to this work were later published in a concise paper (Hill 1979). Springer-Verlag recently posted a PDF version of that paper on the Internet for free distribution. This rewrite was motivated in part by my desire to make more of my earlier research available, and to improve the presentation of this material in a manner that would make it more intelligible. Hopefully there is some new insight here, many years later. Most references to the loaded term *orientation* have been replaced to promote clarity. It has also been my desire to collect the entire body of this information into an electronic format more suitable to its distribution to a wider audience. This is not intended to be a comprehensive review of subsequent research on the subject, but many references, particularly those pertaining to the vision of salticid spiders, have been updated to cover more recent work in this area.

The second version expanded the section on transposition between reference systems for determination of horizontal direction, and improved the photographs. This third version adds only minor text corrections to the conclusions.

2. Summary

Jumping spiders of the genus *Phidippus* often occupy waiting positions during the daytime, from which they pursue sighted prey. These spiders are often required to use an indirect route of access, or a *detour* involving movement away from the immediate direction of the sighted prey, in order to attain a position from which that prey (the *primary objective* of pursuit) can be captured. Selection of a route of access involves movement toward *secondary objectives*, or positions in the surrounding vegetation that have been identified visually by the spider. In moving toward a secondary objective, the spider must turn away from the sighted prey position, but must also retain a memory (*internal representation*) of the relative position (*location*) of that prey at all times.

This memory of the relative position of the prey is expressed in the form of *reorientation turns* toward the expected position of the prey, after the spider has moved to a new position. Each interval between successive reorientation turns during a pursuit is termed a *segment of pursuit*, and each pursuit may include a series of successive segments. It is also possible that *multiple nested objectives* (e.g., use of a *tertiary objectives* associated with movement toward a secondary objective) are used by these spiders in the course of pursuit.

Continuous movement during a segment of pursuit is not necessarily linear, and it can include multiple turns, traverses on silk lines, and even jumps between positions. These spiders will generally continue pursuit to attain a position near sighted prey, even if that prey or primary objective cannot be sighted during a reorientation turn.

To accurately compute the relative direction of the original prey position at the end of each segment of pursuit, as expressed in a reorientation turn, the spider can subtract the direction and distance vector of its own movement from the original direction and distance vector of the prey.

Spiders assessed and recorded target distance, target direction with respect to the immediate route of pursuit (*route-referent* direction), and target direction with respect to gravity (*gravity-referent* direction) when facing a target prior to the start of pursuit. At the start of a segment of pursuit, they also assessed and recorded route direction with respect to gravity (gravity-referent direction). The distance of each pursuit segment was, in part, a function of relative target location (distance and direction), but was also influenced by the immediate plant configuration. During the course of a pursuit, spiders recorded their distance of movement and continuously updated their memory of the relative location (distance and direction) of the target by integrating all route-referent directional information with all distance information that was collected. At the end of a segment of pursuit, spiders executed accurate reorientation turns based on the integrated calculation of route-referent and gravity-referent directions in three-dimensional space.

In cases where there was a conflict between the direction specified by the two reference systems (on a vertical plane), gravity-referent direction was used exclusively during reorientation. During ascent or descent on a vertical route (e.g., a stem), spiders also used visual cues based on the recognition of specific plant configurations, the relative direction of illumination, or variations in the intensity of background illumination, to resolve ambiguities in the determination of radial (horizontal) direction (*image-referent* direction). The ability of these spiders to separate horizontal (*map* or *compass* direction and distance) and vertical (*relative elevation*) components of direction and distance, and to transpose between image-referent and route-referent systems to determine horizontal direction, is also discussed. Apart from the pursuit of prey, these mechanisms are expected to apply generally to the movement and behavior of salticid spiders.

Other experiments demonstrated the ability of these spiders 1) to successfully reorient to a sighted location after a non-linear or winding segment of pursuit in three successive and different dimensions of movement, including movement away from the target location in both horizontal and vertical planes, 2) to move selectively to a position above sighted prey that improves the trajectory of a predatory jump, 3) to remember relative prey direction even when recovering from a missed jump on a dragline, and 4) to turn directly to face a prey position in the absence of visual feedback (after Land, 1971).

3. Introduction

Salticid spiders use their highly developed vision to locate, to evaluate, and to pursue potential prey or positions as they move about. Since many of these spiders dwell on plants, where approach to sighted prey or positions is seldom in the form of a straight line, rapid and effective access to sighted prey requires the ability to utilize an indirect route of pursuit. Three examples of the indirect pursuit of prey by a *Phidippus* are shown in Figures 1-2.

In what maybe the earliest published account of a detoured pursuit by a salticid spider, Bilsing (1920) described the circuitous approach of a *Phidippus audax* in pursuit of a grasshopper. Heil (1936) subsequently documented laboratory observations of detoured pursuits completed by the salticids *Evarcha marcgravi* and *E. blancardi*, (currently *E. arcuata* (Clerck) and *E. falcata* (Clerck), respectively) and regarded their ability to complete these as the *higher accomplishments* (*hohere Leistungen*) of salticid spiders. At the time that the results described in this paper were first reported (Hill 1977, Hill 1978a, Hill 1978b, Hill 1979) these *accomplishments* had received little attention. A salticid clearly requires an accurate memory (*internal representation*) for the relative position (*location*) of prey (or other objectives) if it is to complete a detour of any complexity, particularly if the objective is not visible at all times.

Figure 1. Sequence of predatory pursuit by an adult male *P. pulcherrimus*. A: Drawing of sequential spider positions (1-6) from photographs. B: Schematic diagram of pursuit using conventions adopted in this paper. Spider positions are shown as white circles, the lure as a black circle, and movement is represented by red lines and arrows. A standard lure (dead fly suspended on a hair) was removed immediately as the pursuit began. Note the distinct reorientation turn (4) by this spider to face the expected position of the prey. This spider climbed under an available dragline to get to the stem of this plant(3) before executing a reorientation turn (4).

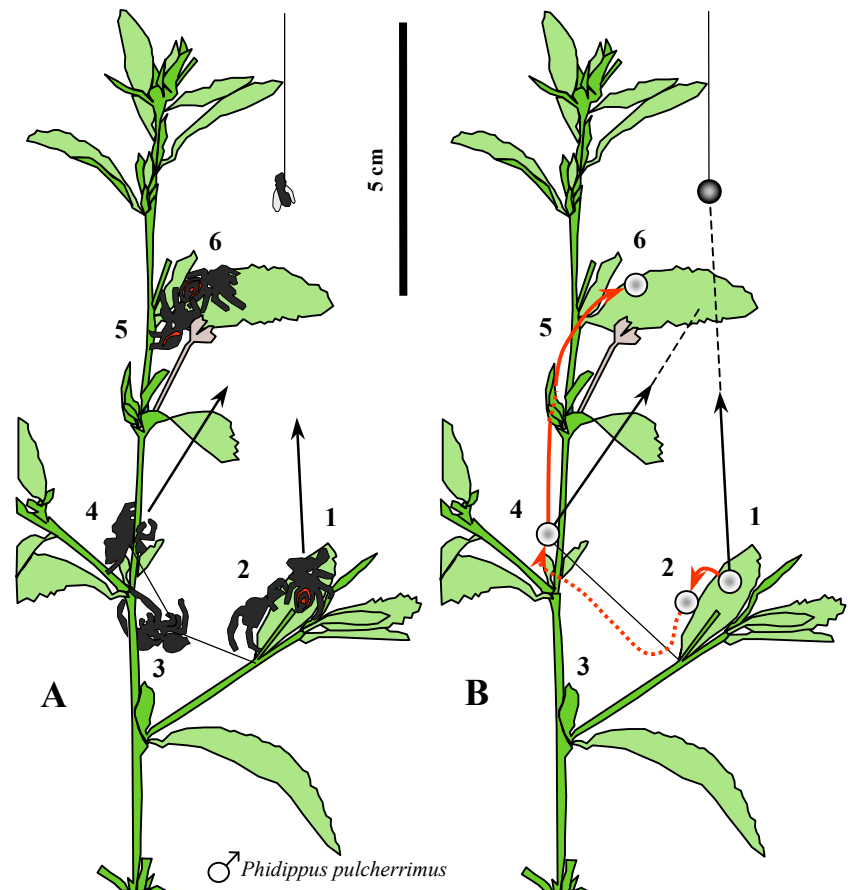



Figure 2. Two photomontages of detoured predatory pursuits by an adult male *Phidippus pulcherrimus*. Sequential positions at which the spider stopped are numbered. In each case the lure (*fly*) was removed immediately after the spider turned to initiate the pursuit (position 1). In both cases, the spider initially moved away from the prey, but directly toward the stem (visible access route), before the first reorientation turn (position 3 in both pictures). A black line indicates the dragline position at B (2), which could not otherwise be seen on this white background.

Since that time, students of the Salticidae have described the use of detours during the pursuit of prey by many different genera, including *Anasaitis*, *Euophrys*, *Euryattus*, *Marpissa*, *Portia*, and *Trite* (Tarsitano and Jackson 1992, Jackson and Wilcox 1993, Tarsitano and Jackson 1994, Tarsitano and Jackson 1997, Tarsitano and Andrew 1999, Hill 2006b). One of these studies found that prey movement increased the likelihood of pursuit, but was not required (Tarsitano and Jackson, 1992). In another study (Jackson and Wilcox 1993), field observations of detoured approaches to araneid spiders in their webs by the salticid *Portia* were described. In one paper (Tarsitano and Jackson 1994) a distinction was made between *reversed-route detours* (requiring movement away from the prey) and *forward-route detours*. Many of the examples contained in the present paper illustrate the fact that common mechanisms related to the internal representation of direction and distance by salticids support *movement in all directions* in three-dimensional space. Consider, for example, a pursuit where a spider has to turn back on its route (Figure 25).

After a review of general methods and related research on salticid behavior, this study will focus on a series of experimental observations of detoured predatory pursuits conducted by the relatively large, North American jumping spiders of the genus *Phidippus*, to describe how these spiders use information relative to distance and direction to successfully complete these pursuits. This research was not meant to test the navigational limits of these spiders. At the same time, related abilities of *Phidippus* that improve their success as predators, such as their ability to approach prey from the opposite side of a branch in order to conceal their movement from that prey, will also be described. From the inclusion of many descriptive examples of this behavior, it is hoped that the reader will gain a greater appreciation for the relative sophistication of these animals. In nature, salticids are very versatile. They readily use not only plants, but also silk lines and even their own ability to jump, in order to complete a route of pursuit.

3. General methods of study

The species of *Phidippus* that were observed during the course of this study are listed in Figure 3. All experiments were performed with individuals of *P. pulcherrimus*, and most of these were repeated with other species of *Phidippus* to extend the generality of the results. Selection of *P. pulcherrimus* as the primary subject of study was based on the ease with which these spiders adapted to laboratory situations, as well as their willingness to run pursuits under artificial conditions. This was without doubt related to the habitat of these spiders, which generally dwell upon herbaceous plants in an open field. In contrast, individual *P. otiosus* (Hentz), a spider often found living in trees (Edwards 1980), usually preferred to climb to a higher position rather than to pursue prey in a laboratory situation.

<i>Phidippus</i> Species	Collection Site	Spiders (SN)
<i>P. pulcherrimus</i> Keyserling 1885	Immatures collected from resting sacs on the herb <i>Euthamia minor</i> at Big Prairie, Ocala National Forest, Marion County, Florida, and reared to maturity	females 1-6 male 7
	Offspring of animals captured at Big Prairie	females 8-14 males 15-18
<i>P. princeps</i> (Peckham & Peckham 1883)	Immatures observed living on <i>Euphorbia esula</i> herbs at Groveland Field, Hennepin County, Minnesota	---
	Collected at Groveland, reared to maturity	female 19 male 20
<i>P. regius</i> C. L. Koch 1846	Collected as immatures Living on herbaceous plants At Big Prairie, immature	female 21 male 25
	Collected at Big Prairie Reared to maturity	females 22-24
<i>P. clarus</i> Keyserling 1885	Immatures collected from sweep of grasses and herbaceous plants at Big Prairie, reared to maturity	males 26-28
<i>P. audax</i> (Hentz 1845)	Adults observed along the margin of Newnan's Lake, Alachua County, Florida	---

Figure 3. Species and individuals of *Phidippus* observed during the course of this study. Individual spiders were identified with each presentation of experimental results according to the spider numbers (SN) shown in the right-hand column. Thus SN 24fREG refers to spider number 24, a female *P. regius*. Classification of all spiders follows that given in the recent revision of the genus *Phidippus* by Edwards (2004).

Initially several sequences of pursuit behavior were recorded during field observation of *P. princeps* in Minnesota (Hill 1977). Subsequently, a series of experimental structures representing plant configurations were constructed in the laboratory to control environmental information and prey access or pursuit options available to each spider. Individual spiders were placed on each experimental structure, and then stimulated to conduct a pursuit by movement of a dead house fly (*Musca domestica*) cemented to the end of a long strand of hair (the *standard lure*). In most trials, this standard lure was quickly moved out of the field of vision of a spider prior to movement by that spider, so that it could not provide visual feedback and thus impact subsequent behavior. In some cases, this standard lure was also used to guide the spider into a starting position. Many trials required measurement of both the position and the direction faced by the spider. In most cases this was accomplished by direct observation of a numbered position occupied by the spider, and a numbered position faced by the spider, facilitated by visual alignment of a wooden rod with the mid-line (mid-sagittal) axis of the spider. This task of visual alignment during observation was facilitated by the presence of conspicuous and symmetrical groups of light-colored scales on the carapace of each spider, as well as by the relatively large size of *Phidippus* jumping spiders (Figure 4).

Unless otherwise specified, artificial lighting in the laboratory was provided with 100 w or 150 w (1500 to 2500 lumen) incandescent light bulbs, situated inside aluminum parabolic reflecting lamps placed 0.5 to 1.5 m above each experimental structure. Laboratory temperature was constantly held near 25 C.

As noted by Kaestner (1950) in his study of *Evarcha falcata*, individual salticids can have distinct and consistent personalities, or individual modes of behavior when observed in a particular context. For this study, spiders were tracked and managed as numbered individuals (identified in Figure 3), and some individuals were markedly better performers in a given situation than were others. Similar variation in the behavior of individuals was noted by Tryon (1940) in his study of laboratory rats. Hundreds of individual spiders were screened, resulting in the selection of the relatively few (N=28) which are mentioned in this study. *Note that this was not intended to be a statistical compilation of the tendencies of field-collected animals.* This selection was based solely on whether or not these spiders would actively, and *repeatedly*, pursue a standard lure under laboratory conditions. Nonetheless, virtually all *Phidippus* observed in the course of this study, including rejects, demonstrated an ability to run a detoured pursuit.



Figure 4. Distinctive scale patterns on the prosoma of *Phidippus* spiders facilitated the estimation of facing direction by an overhead observer. At top is an adult male *P. pulcherrimus*, at bottom an adult female *P. regius*. Both spiders were reared from immatures collected at Big Prairie in Ocala National Forest, Marion County, Florida.

After screening, considerable attention was devoted to the care of *runners*, to maintain their responsiveness at a healthy optimum. A degree of food deprivation was required for this purpose. Each spider was reared in a separate Petri dish, and was provided with droplets of drinking water via a small piece of sponge several times each week. Care was taken to avoid saturation of these small sponges, which could lead to drowning of the spider. A thirsty spider would immediately swagger in the direction of newly available moisture, as if divining its presence with its tapping front legs. Each spider was fed with flies (either *Musca domestica* or *Drosophila melanogaster*) but only when the opisthosoma was markedly reduced in size.

Between repetitive trials, dragline silk was wiped off of each apparatus. It was assumed that any physical or chemical cues that remained were neutral with respect to direction, and in most trials (e.g., prey sighted at variable direction from horizontal bar), these cues would not have been of any use in solving a direction the distance problem at hand.

Standard statistical methods, consistent with definitions provided by Siegel (1956), Runyon and Haber (1971), and Mendenhall and Schaeffer (1973), were used for the analysis of data. The χ^2 test was used for the analysis of simple counts and data arranged in contingency tables. For presumed parameters, means were presented ± 1 standard error. Student's t test was used to determine either the significance of the difference between two mean values, or the significance of the difference between one mean and a fixed value. Paired data were analyzed by means of linear least-squares regression, the Pearson r correlation coefficient, and the z_r test for the significance of r .

4. Salticid vision

Among spiders and arachnids as a group, salticids are remarkable for the degree of development of their vision, particularly with respect to the high resolution and relative size of their forward-facing anterior medial eyes (AME). As shown in figures 5-6, *Phidippus*, like most other spiders, have eight eyes affixed toward the front and top of the carapace. Each "simple" eye has a single fixed lens. Apart from the relatively small posterior-medial eyes (PME), there are two types of eyes, represented by the two anterior medial or *principal eyes* (AME), and the four *lateral eyes* (anterior lateral eyes or ALE, and posterior lateral eyes or PLE). All known salticids exhibit the same pattern of large, forward-facing AME, flanked by forward facing ALE (sometimes further back, as in *Lyssomanes*), with a distinctive optic quadrangle defined by the lateral eyes (ALE and PLE) on the antero-dorsal carapace. However, there is considerable variation with respect to the development of the PME, which are diminutive in most salticids including *Phidippus* (Blest 1983). The PME of most salticids have been described as *vestigial* (e.g., Blest 1983), but in *Phidippus* they are connected to the central nervous system via large diameter nerve fibers (Hill 1975), suggesting a specialized role in these spiders. In many salticids much larger PME provide peripheral vision in a direction above the carapace that does not overlap with the visual fields either the ALE or the PLE (Blest 1983, 1984, Land 1985). There is also considerable variation in the Salticidae with respect to receptor spacing and optical resolution of the AME (Blest 1985, 1990, Blest and Sigmund 1985).

The AME provide the spider with remarkably high resolution over a limited field of vision, whereas the lateral eyes occupy the four corners of a quadrangle at the top of the prosoma, and provide overlapping peripheral vision with lesser resolution in all directions at the same time (Homann 1928, Land 1969a, 1974). This functional separation of foveal resolution (AME) from peripheral vision (lateral eyes) allows the spider to combine a large field of peripheral vision (lateral eyes), along with high visual acuity (AME), into a relatively small volume within the prosoma (Homann 1928, Land 1969a).

The anterior medial eyes (AME) are often called *principal eyes* because of their unique structure and capabilities. They are indispensable for visual discrimination by salticids (Homann 1928, Heil 1936, Kaestner 1950, Dzimirski 1959). Each AME consists of a large cornea and lens affixed to the front of the carapace, connected to a long eye tube (see Figure 6) that can be moved up and down, from side to side, and also rotated, by six attached muscles (Land 1969b).



Figure 5. Frontal view of an adult female *P. texanus* that was facing the camera. The large AME (anterior medial eyes) are flanked by the more widely separated ALE (anterior lateral eyes). This spider was reared from an immature hatched from an egg sac collected in New Mexico by Dr. David B. Richman.

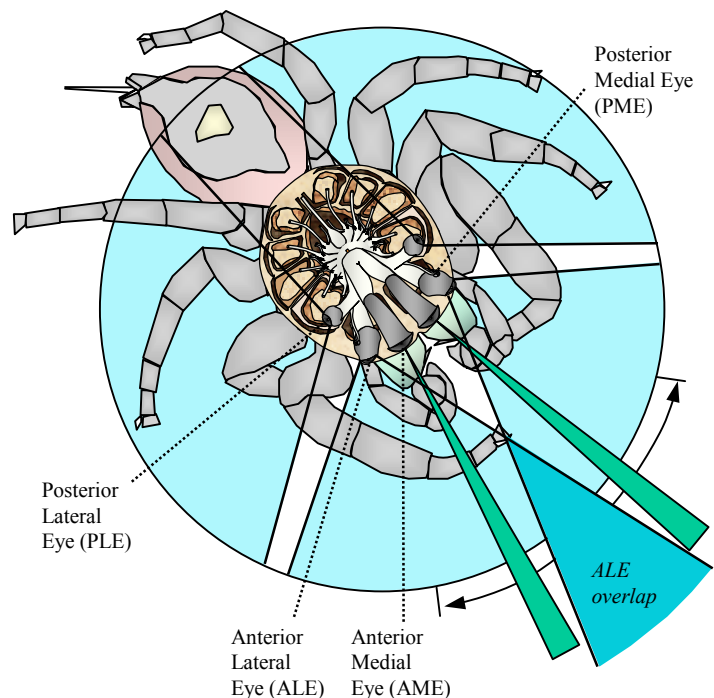

Figure 6. Diagram of the approximate visual fields of *Phidippus* as viewed from above, showing the eyes and their respective optic nerves connected to the prosomal CNS (based on Land 1969a, Duelli 1978, and Hill 1975). The posterior lateral (PLE) and anterior lateral eyes (ALE) provide the spider with a 360-degree survey of its surroundings. Field of vision of the ALE overlap in front of the spider. Each anterior medial eye (AME) consists of a long tube that can be moved independently to scan the area in front of the spider with high resolution. The function of the small posterior medial eyes (PME) is not known.

Each AME can be moved independently or in loose coordination with the other AME. Identified movements of the AME include spontaneous or unstimulated movement, saccades to bring both eyes to a target, tracking to follow a moving target, and scanning. Scanning involves rotation as well as horizontal and vertical movement of the eye tubes, and is thought to relate to object recognition (Land 1969b, 1972b, 1974).

The transparent matrix of each AME eye tube, just in front of the retinae, is curved at the rear (*pit* area), and serves as a secondary lens with additional magnification of about 1.2 to 1.54 (Blest, McIntyre, and Carter 1988, Williams and McIntyre 1980). Thus each principal eye contains a *compound* or *telescope* lens.

A four-tiered retina comprised of bipolar neurons is situated to the rear of each AME eye tube, with tier layers designated IV, III, II, and I from the front to the back (Blest, Hardie, McIntyre, and Williams 1981). As viewed from the front, each retina is boomerang-shaped and covers a relatively small field of view (Land 1969a, 1969b). Spacing of receptors in layer I provides the highest level of visual acuity, estimated at a remarkable 2.3 arc minutes (0.04°) in the salticid *Phiale* (Blest 1985). Green-peak (520 nm) and UV-peak (360 nm) receptors are found in layers I and IV respectively, correcting for chromatic aberration (different wavelengths have different focal lengths) (Blest, Hardie, McIntyre, and Williams 1981). In addition, step-wise placement of receptors in layer I provides accommodation for objects from 3 cm to infinity in distance, in front of the spider (Land 1969a, Blest, Hardie, McIntyre, and Williams 1981). DeVoe earlier (1975) found the green-peak (532 nm) and UV-peak (370 nm) receptors in the AME, but also found cells that exhibited both green and UV peaks (370+525 nm). Yamashita and Tateda (1976) previously reported this correspondence of layering to wavelength sensitivity, but found four different receptors in the AME (360 nm, 480-500 nm, 520-540 nm, and 580 nm).

Peaslee and Wilson more recently (1989, *Maevia inclemens*) showed that AME movement could be elicited in response to illumination ranging from UV (330 nm) to deep red (700 nm), but the peaks corresponded to the green-peak and UV-peak receptors that have been generally found. Lim and Li (2006) found that UV light significantly impacted courtship behavior in the salticid *Cosmophasis umbratica*. Much earlier, Crane (1949) and Kaestner (1950) provided limited demonstrations of the general role of color vision in the evaluation of conspecifics and potential prey by salticid spiders.

The lateral eyes (ALE and PLE) are known to function as movement detectors, capable of directing a turn by the spider to face a moving object with the AME (Petrunkevitch 1907, Hardie and Duelli 1978, Homann 1928, Land 1971, 1972a, 1974, Eakin and Brandenburger 1971, Dill 1975, Duelli 1977, 1978, 1980).

Receptors in the lateral eyes are fairly uniform (Hardie and Duelli 1978), with peak sensitivity at the wavelength of 536 nm in *Menemerus confusus* (Yamashita and Takeda 1976). In the PLE and part of the ALE, receptor separation limits the angular resolution to about 1.0° of arc (Land 1969a). Duelli (1978) demonstrated with the salticid *Evarcha arcuata* that successive stimulation (by a *decrease* in light intensity) of only two receptors elicited a facing turn toward the second of the two stimuli. Unlike the AME, lateral eye sensory neurons are unipolar, and cell bodies are clustered to the side of each eye (Hill 1975).

There is also much support for the view that the ALE are critical to the measurement of distance by these spiders (see Figure 7). *Phidippus* make frequent direct turns to face stationary objects in their surroundings (e.g., secondary objectives as shown in figures 19B, 19E, 36, 39, 41, and 107). They also turn and move directly toward objects without scanning with their AME before the turn (e.g., Figure 105). These examples strongly support the hypothesis that peripheral vision includes a significant component of form recognition, even if at a lower resolution than afforded by the AME. Each lateral eye appears to be connected equally to two completely different tracts of interneurons in *Phidippus*, supporting the hypothesis of multiple functions (Hill 1975).

The ability of salticid spiders to resolve distance (depth perception) is of considerable relevance to their ability to observe and to retain a memory of relative prey position, as well as their ability to initiate an accurate jump trajectory toward a prey position. Of the four *facing eyes* at the front of a salticid (the AME and ALE), the ALE have the greatest separation, as well as an overlapping field of vision (Figure 6), suggestive of binocular vision and depth perception. Homann (1928) demonstrated that blinding of a single ALE reduced the accuracy of a jump to the same extent as did blinding of both ALE. The AME may also provide some distance information (Homann 1928, Heil 1936), but the greater resolution of these eyes is offset by their proximity. Indeed, one would expect a tendency toward greater separation of these eyes if they played a major role in depth perception. Since points greater than 3 cm from the spider come to focus in a single receptor layer of the AME, it is unlikely that a single AME can provide monocular depth perception based on focal plane (Land 1972b). Data from the fixed ALE and the moving AME is most likely superimposed or integrated within the central nervous systems of these spiders, but no related mechanism or structure has been demonstrated.

When compared to the wide-angle lenses of the PLE, the lenses of the ALE are of significantly longer focal length, corresponding to a more restricted field of vision to the front of the spider (Land 1969a). Peripheral angular resolution of for much of the ALE, as measured by separation of the receptors, is comparable to that of the PLE (about 1.0 degrees of arc), but this resolution increases to about 0.5 degrees of arc for the ALE receptors that receive stimuli from the field of binocular overlap of the ALE, directly in front of the spider (Land 1972b, 1974). This increase in angular resolution supports the view that the ALE play a key role in the depth perception of these spiders.

A simplified triangulation model of the theoretical limit to binocular resolution, as a function of the separation and angular resolution of the ALE for a point stimulus, is depicted in Figure 7. The resolution of distance should decline as the distance of a sighted object increases toward a limit in the 10-20 cm range.

In a real-life situation, an object observed by a spider is much more than a point. If an object subtends a series of distance samples of varying accuracy. Statistical treatment, or averaging of these data within the central nervous system of the spider could greatly increase the ability of these spiders to resolve distance beyond these simple limits. For example, the form of a stationary housefly (*Musca domestica*) at a distance of 20 cm might subtend 15-20 receptors in each ALE. With no sophistication for edge detection this could still provide the spider with up to 400 eye-to-eye comparisons, or distance estimates, of varying accuracy. These spiders may also use the distance to larger (more distance sampling points) plant structures associated with a prey position to more accurately measure distance.

Insects may use parallax gained from their own movement to extend the range of their depth perception (Horridge 1977). *Phidippus* have been observed to occasionally rotate the mid-sagittal plane when facing an object (Figures 8, 114), and it is possible that this movement may facilitate the resolution of distance by these spiders through the alignment of ALE receptors. Humans can also best determine the distance of a rod when that rod is vertical with respect to a vertical sagittal plane (Blake, Camisa, and Antoinetti 1976).

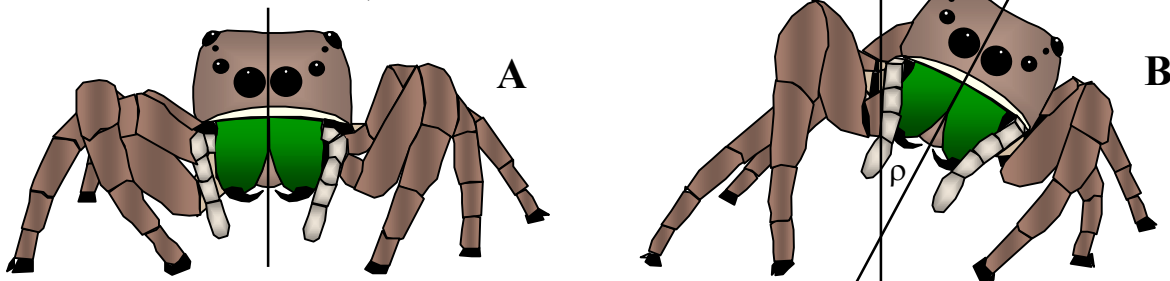

Figure 8. *Phidippus* before (A) and after (B) a prosomal rotation of magnitude ρ . When surveying an object, these spiders frequently tilt the prosoma to one side, as if attempting to secure additional information. This behavior may be related to the evaluation of form by the scanning AME, but it could also be employed to improve the resolution of distance by providing better alignment for additional eye to eye (binocular) comparisons.

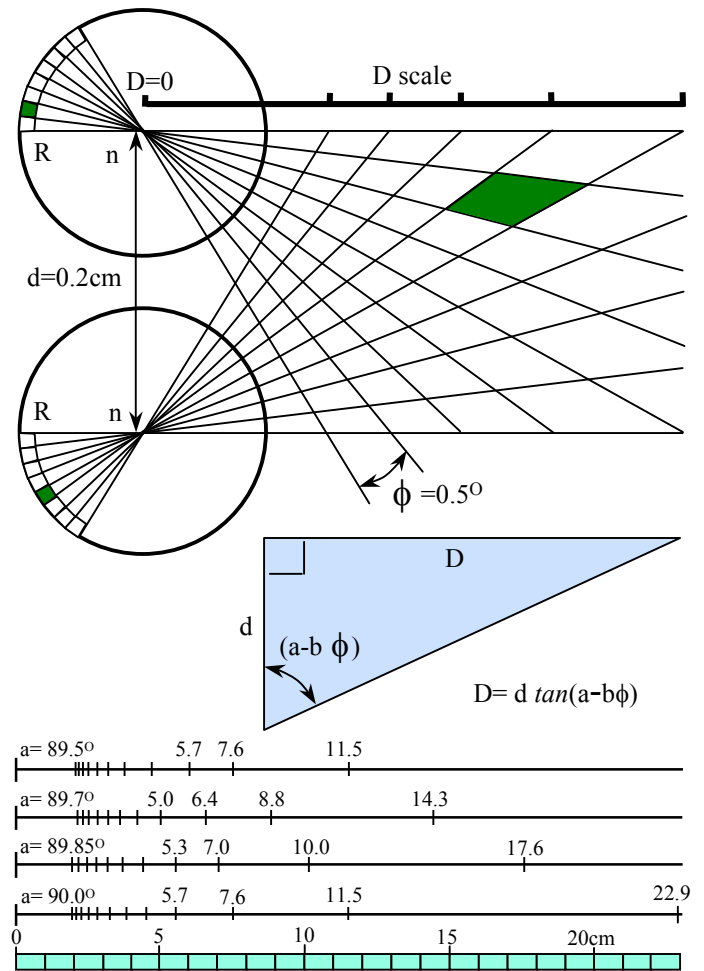

Figure 7. Hypothetical resolution of distance through triangulation supported by separation by receptors of the ALE, for a point source of light. This diagram depicts the retinæ (R) and nodal points (n) of the ALE (large circles at left). Each of the quadrangles or sampling units in the visual field to the right corresponds to the simultaneous stimulation of a unique pair of receptors, one from each eye, as indicated by the shaded areas. Given ϕ , the angular resolution of the visual receptors, and d , the separation of the eyes (nodal points), one can calculate a set of estimated values for limits of the distance sampling intervals (D) as shown in the scale at the top of the diagram, by substituting integer values of (b) into the relationship shown in the small triangle above. For this estimation, each value of (a) should be chosen so that $(90^\circ - \phi) \leq a \leq 90^\circ$. Four possible scales of boundary values for distance resolution by the ALE of *Phidippus* are shown at the bottom, based upon $\phi = 0.5^\circ$ and $d = 0.2$ cm, with (a) given in each case in parentheses. (a) can be thought of as a receptor alignment or offset variable, which should vary depending on what pair of receptors is selected for this estimate. Integration of data provided by multiple sets of receptors could greatly increase resolution beyond the estimates shown here. Both samples suggest that distance resolution of a point object by a *Phidippus* drops off rapidly at distances beyond 10 cm.

5. Open loop facing turns in the absence of visual feedback

Salticid spiders turn rapidly to face moving objects when these appear within the extensive field of vision of their lateral eyes. These *facing turns* are characteristic of salticid behavior in general. As depicted in Figures 9-10, facing turns can include both lateral or stepping movement (α component) and elevation of the prosoma (β component).

Land (1971) demonstrated the ability of salticids (*Phidippus*) to execute an accurate α facing turn in the absence of visual feedback during that turn. In other words, these spiders used only the information provided by the initial sighting of a stimulus by a lateral eye to control the extent of a lateral or stepping turn. Mittelstaedt (1962, 1964) referred to this as *open loop* behavior. Land actually measured the stepping movement and turning angle of each spider indirectly, by measuring the angle through which a spider, affixed by the carapace, would turn a paper ring held by the legs. Bennett and Lewis (1979) repeated the same experiment, using *Trite* affixed by the prosoma to rotate a piece of floating filter paper. Their results were essentially the same.

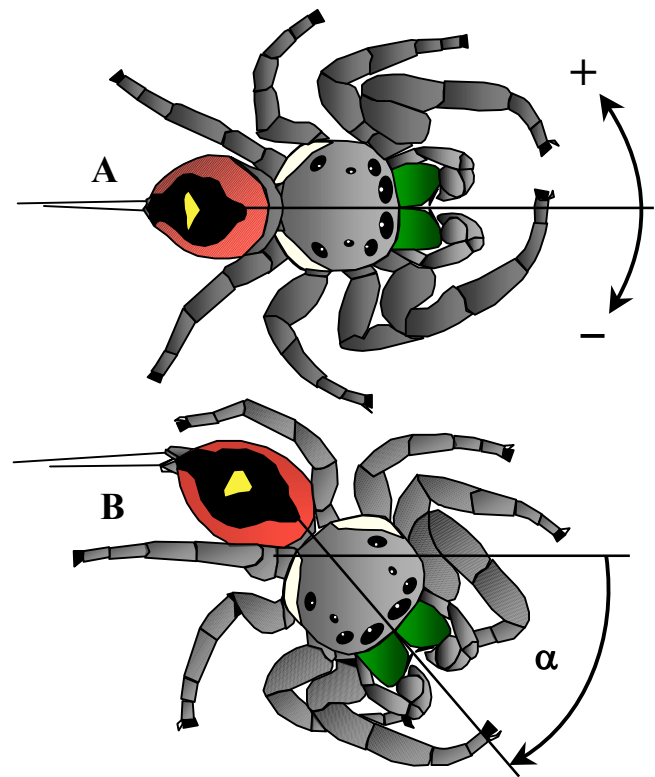

Figure 9. The α or lateral component of a facing turn. Adult male *P. pulcherrimus* before (top) and after (bottom) completing a turn of magnitude α in a horizontal plane. As a convention the sign (+ or -) of α is based on a top-down view as shown in (A). A stepping pattern like that described by Land (1972a) is usually involved in an α turn, although a spider can make small α turns in place by pivoting, without moving the footpads off of the surface.

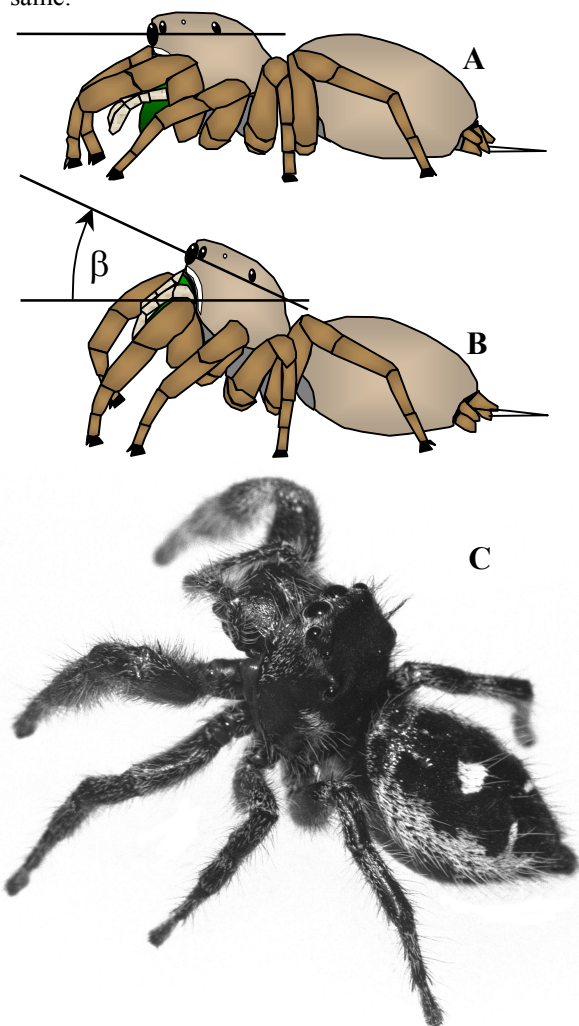

Figure 10. The β or dorso-ventral component of a facing turn: *Phidippus* before (A) and after (B) completion of a rotation of the prosoma in the sagittal plane of magnitude β . A β turn involves a pivot or tilt to either raise (+ magnitude, as shown here) or to lower (- magnitude) the prosoma, and the spider may not need to move its footpads off of a surface to accomplish this. *Phidippus* (and many other salticids) can turn to look directly up from a surface at an inclination of 90°, and they can also raise the pedicel and lower the front of the prosoma to look down over the edge of a surface. C: β turn by adult female *Phidippus audax* from Ithaca, New York. D: Extreme β turn by adult female *Thiodina sylvana* near Lake Alice in Gainesville, Florida. The opisthosoma was rotated to the left to facilitate this turn.

A new demonstration of the accuracy of α facing turns by *untethered* spiders, in the absence of visual feedback, is described in Figures 11 and 12. A similar demonstration of the accuracy of β facing turns in the absence of visual feedback is described in Figures 13-14. Observed β facing turns consistently fell short of the stimulus position, an observation that may be related to the fact that the turns were nonetheless sufficient to position the AME for a scan of the sighted stimulus. Turns with both α and β components (shown in Figure 15) were frequently observed, but the accuracy of these turns was not measured. It is a reasonable assumption that these turns in both horizontal and vertical dimensions are just as accurate as the measured turns., regardless of the orientation of the spider.

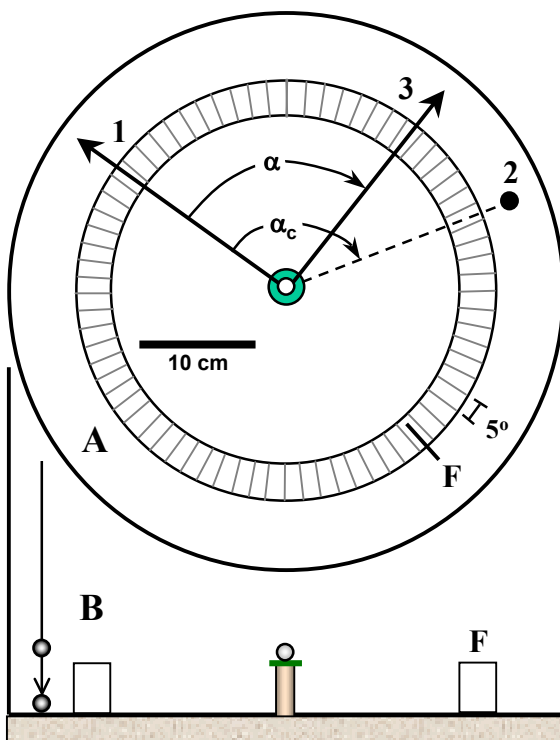

Figure 11. Apparatus used to measure the ability of an untethered *Phidippus* to complete an accurate α (lateral) turn to face prey in the absence of visual feedback during the turn, viewed from above (A), and in vertical section (B). The apparatus was constructed from heavy white paper. The spider (open circle at center) rested on a small (2 cm diameter) circular platform at the center of a large cylinder. A numbered scale (F), used to measure the direction faced by the spider, encircled the prey position. As shown in (A), the direction initially faced by the spider (1), the position at which prey was presented (2), and the position faced by the spider after the turn (3) were recorded in sequence by an observer looking directly down from above the cylinder. As shown in (B), the prey (standard lure) was dropped into the trough before the spider completed its turn, for all recorded trials. From (1), (2), and (3), value of α_c , or the magnitude of a required to face the original prey position, and the actual value of α elicited by the stimulus were calculated as shown in (A).

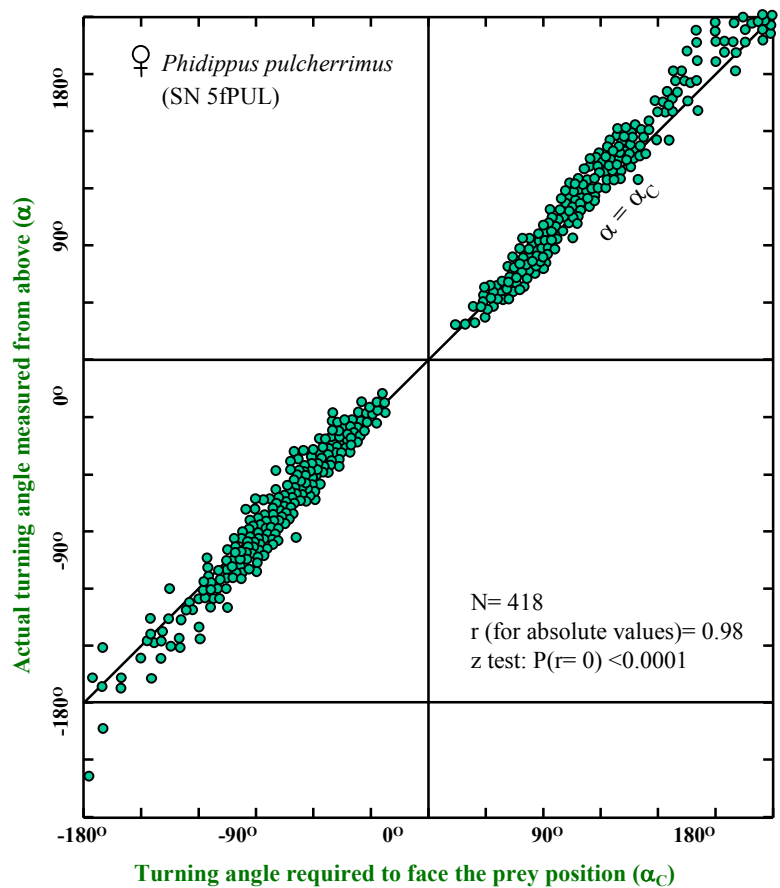

Figure 12. Actual angle of lateral turn (α) as a function of the angle required to face the prey position (α_c), based on a single series of trials using the technique described in Figure 16. This female *P. pulcherrimus* demonstrated the ability to turn in either direction (+ or to the left, and - or to the right) with a high degree of precision, in the absence of visual feedback with respect to the original prey position. Although comparable to similar results obtained by Land (1971), none of the small lateral turns that he recorded in response to a prey stimulus were observed. An interesting feature of this behavior lies in the fact that the shortest of two possible turns (e.g., 140° to the left instead of 220° to the right) was always observed. Observations were accurate within a $\pm 5^\circ$ range.

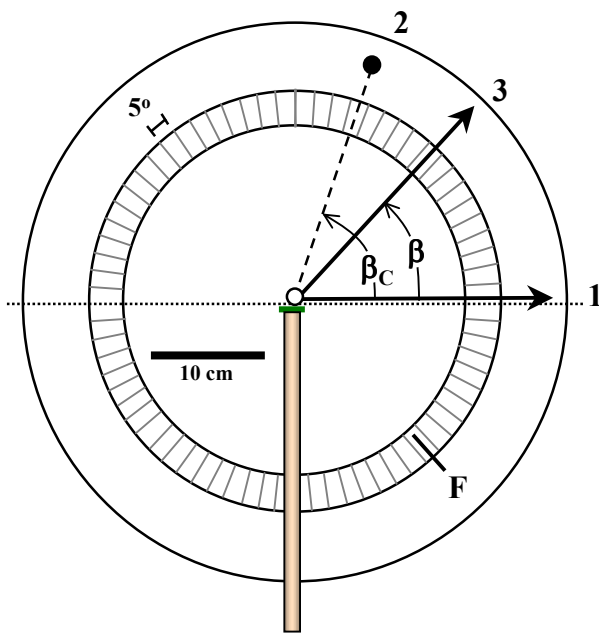

Figure 13. Apparatus used to measure the accuracy of β (dorso-ventral) turns, as viewed from above. In this case, the waiting spider occupied a small horizontal platform (at center). Before each trial, the spider was shown a prey stimulus (standard lure) at position (1), to return it to a standard starting position. Following presentation of the lure at (2), the spider turned to position (3). From observed values of (1), (2), and (3), turns required to face the prey position (β_C), and the actual turn (β) were calculated. As in observations related to A turns, the fly was dropped quickly so that it could not be seen by the turning spider. Determination of the direction faced by the spider in each case was consistent with the vector defined in Figure 14.

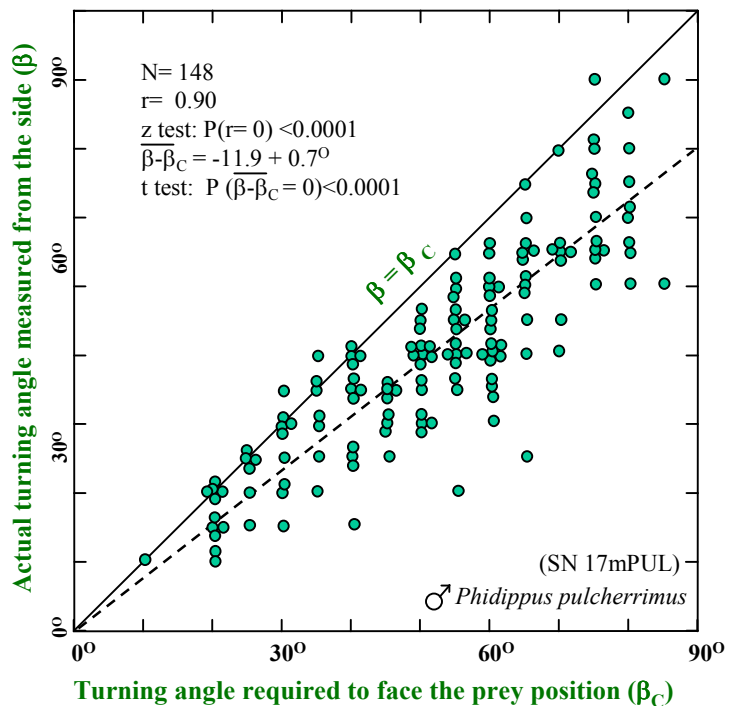
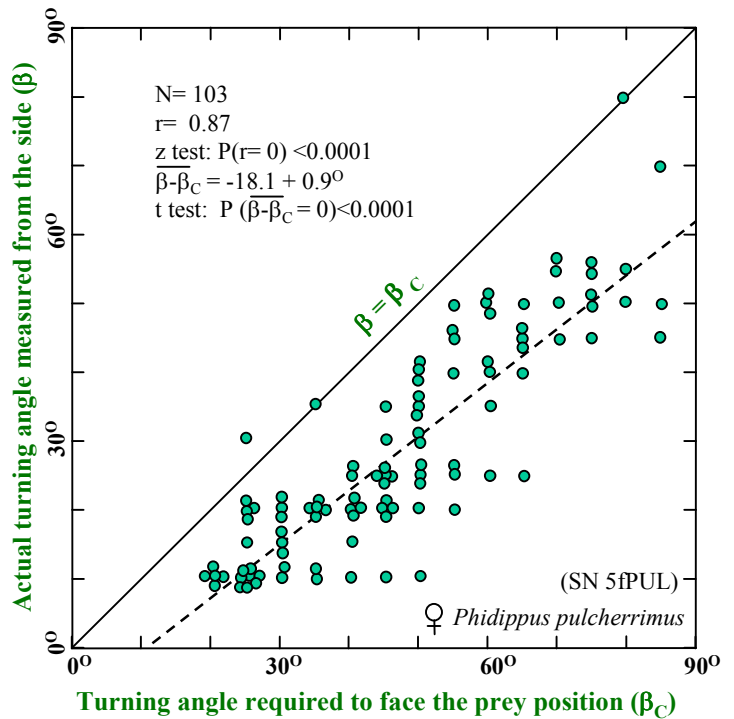

Figure 14. Highly significant correlation of dorso-ventral (β) turns with the prey direction, observed for a female (top) and a male (bottom) *P. pulcherrimus*, based on use of apparatus shown in Figure 18. Measured turning angles in each case were significantly smaller than the angles required to face prey directly. Many of these turns were executed in two visibly distinct segments executed in succession. Subsequent presentation of the prey in the original position often elicited an additional, small β turn to face the prey, most likely a correction. As in subsequent figures in this paper, a dashed line depicts the linear least-squares regression line of Y on X in each case.

The fact that visual feedback is not required for completion of an accurate turn to face a stimulus that appears in the peripheral vision of a salticid does not imply that visual feedback cannot be used in a different context, or that it is not used when available. When a second presentation of the prey stimulus was made after completion of an α facing turn executed in the absence of visual feedback (apparatus depicted in Figure 11), each spider quickly made a small correcting turn to face the prey, whenever the initial turn was slightly off the mark. These small correcting turns were often observed when the prey was continuously visible. They were clearly the product of visual feedback, presumably at the end of the original turn, and they may reverse the direction of the original turn. *Phidippus* spiders were also observed to combine a continuous series of accurate orientation turns with forward stepping movement during the pursuit of moving prey, suggesting that they were capable of using continuous or at least iterative visual feedback during these pursuits (Figure 16). These may also have been closed-loop turns directed by the AME (after Land 1972b).

Salticids also appear to turn or to execute *facing turns* frequently in the absence of specific visual stimuli. When walking from plant to plant, both *Eris* (*E. militaris*; Hill 1978a) and *Phidippus* frequently stopped to perform an extensive series of facing turns, often encompassing a full 360 degrees. More restricted bouts of visual survey, consisting of a series of small turns directed toward the vicinity of a sighted plant structure or other immobile object, were also frequently observed. The *partial turns* that Land (1971) and Bennett (1979) frequently observed in response to a directional stimulus may have been artifacts related to the set up of their experiments, as these were not observed with untethered *Phidippus* (Figure 12). Based on extensive field observations of both *Eris* and *Phidippus*, it appears unlikely that these small turns can be justified as a form of energy conservation as suggested by Land. These salticids were observed to turn frequently in a natural setting, and many of their turns were directed toward both animate objects, such as leaves moving in the wind. As a rule, small or partial turns in response to a visual stimulus that was not directly in front of a spider have not been observed.

Subsequent sections of this paper will address the case of the *reorientation turn* of salticids, a special kind of *facing turn* in which these spiders turn to face the expected position of the prey that they have been pursuing. It will be shown that, in general, reorientation turns are not directed toward a *visual stimulus*, but are instead directed toward a *calculated position* based on use of an internal location reference or memory of the original position (direction and distance) of the prey stimulus, that is updated to account for the subsequent movement of the pursuing spider.

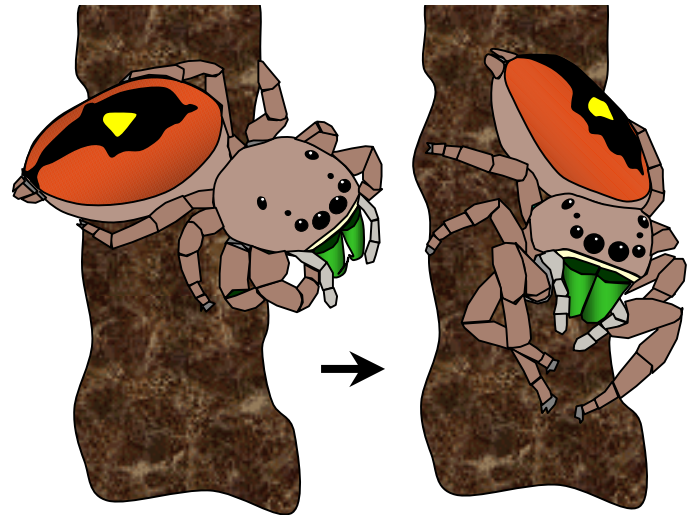

Figure 15. Smooth execution of a turn involving both α and β components of movement. The ability of *Phidippus* to execute an accurate facing turn in three dimensions, involving both the elevation of the prosoma (β) and side-stepping on an irregular surface (α), was readily demonstrated with presentation of a fly stimulus. Presentation of prey above and behind a spider resting on a horizontal surface elicited a rapid 180° a turn coupled with a β turn, in a single movement. Often a small, subsequent β correction, apparently based on visual feedback from the prey, was required to face the prey directly.

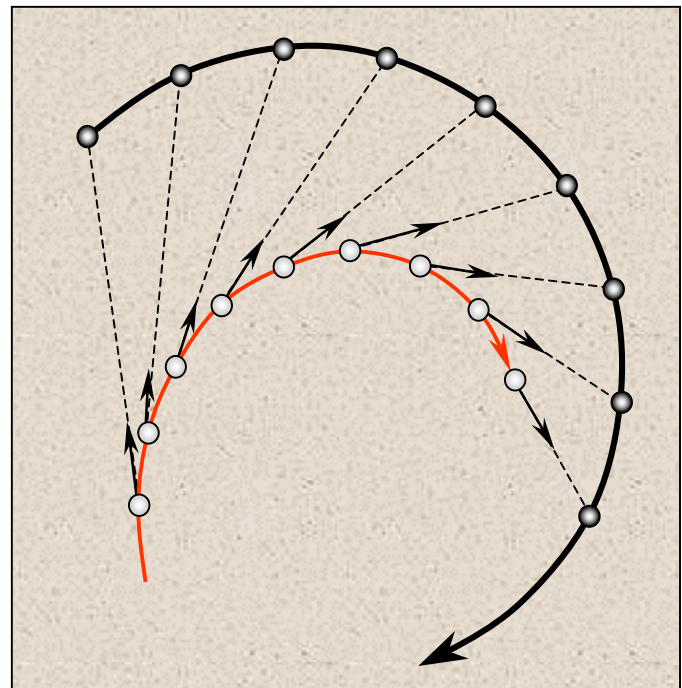

Figure 16. Approximate relationship of moving spider (open circles) to a moving fly (closed circles) on a flat surface. A motivated *Phidippus* can continuously turn to face moving prey when then are running during a pursuit. It remains to be determined whether they can actually lead (aim in front of) the prey in this situation.

6. Searching and watching

A predator may either search for prey in an active manner, or it may occupy a waiting position until prey moves into sight, and then pursue that prey (Carthy, 1965). I have observed many salticids (including *Anasaitis*, *Eris*, *Habronattus*, and *Phidippus*) moving about during the daytime in what appeared to be a wandering or search pattern of activity. *Phidippus* (Gardner 1965, Enders 1975, see Figure 17) have often been observed to occupy waiting positions in vegetation, from which they can pursue sighted prey. The salticid *Evarcha* has also been observed in waiting or survey positions (Heil 1936, Kaestner 1950, Plett 1962a).

Perhaps at the opposite extreme in the continuum between searching and watching is *Synageles*, a salticid ant mimic that moves about quickly with only brief pauses (Kaestner 1950). The salticids *Salticus* (Kaestner 1950, Drees 1952, Plett 1962a, 1962b) and *Sitticus* (Kaestner 1950) have also been described as constant searchers.

Under certain conditions, however, a spider may switch from watching or waiting to active searching for sedentary prey. As one example, one of the female *P. pulcherrimus* (SN 1fPUL) observed during the course of this study was enticed to run a series of indirect pursuits with a standard lure, similar to those depicted in Figures 1 and 2. At the end of each pursuit, this spider would return to a waiting position, facing down and crouching near the top of a stem. During one pursuit run, this spider discovered a sedentary aphid among the terminal leaflets of a branch, and then returned to the main stem to feed on this aphid. This spider proceeded to repeat this entire sequence three more times before I interrupted it, each time moving out to the terminal leaflets of various branches of the plant (sweet clover, *Melilotus alba*) and conducting an extensive tactile survey marked by constant turning and tapping of the leaflets with the first pair of legs, until an aphid was located and captured.

This ability to switch between searching and watching or waiting can be quite useful. When available prey are moving actively, or alighting on occasion, the spider can maximize its observation time, minimize the energy expenditure or water loss associated with activity, and reduce the possibility of capture by remaining immobile in a relatively concealed position, and by pursuing prey only as it appears in the area of visual survey. Waiting is clearly less effective for the detection of sedentary prey.

Figure 17. (above) Adult female *P. clarus* surveying the surroundings from a vantage position on a goldenrod gall (*Solidago*) in Minnesota. (below) This *P. clarus* sighted and pursued this leafhopper from this position, and then returned to the same position, under a dried gall, to feed on it.



Like *P. clarus* (Figure 17), *P. princeps* and *P. pulcherrimus* both tend to occupy waiting positions near the top of herbaceous plants in an open field. These positions are generally on the main stem of the plant, facing down. This waiting position may facilitate both of the two major determinants of success as a predator: 1) the ability to detect prey, and 2) the ability to rapidly reach that prey before it escapes. A position near the top of the plant not only gives the spider a greater range for a predatory jump (downward, where gravity contributes to the range of the trajectory), but it also facilitates the visual survey of the illuminated upper surfaces of leaves on which flying prey may alight, or visibility of a greater area below the spider from which either dangerous predators or valuable prey could emerge. An elevated position may reduce the possibility of attack from above from a walking predator, but it may also expose these spiders to a greater risk of attack by a flying predator. Geometrically, a waiting position near the main stem, as opposed to a position on a peripheral branch, should minimize the average pursuit distance required to approach sighted prey, and the main stem itself represents a useful route for pursuit.

This position may also be related to safety or escape from predators. *Phidippus* spiders, like many other animals (e.g., woodpeckers or squirrels), can also quickly conceal themselves by moving quickly around to the opposite side of a branch or stem (Figure 18). This alert response is one of the reasons that few people have ever seen these animals. It is noteworthy that individual *P. pulcherrimus* that had been reared for their entire lives in Petri dishes would readily assume and pursue prey from these downward-facing waiting positions on main stems. Greenquist and Rovner (1976) reported a tendency for certain lycosid spiders to align themselves in a downward-facing position on artificial foliage, so the advantages associated with these positions are apparently not exclusive to the Salticidae. I recently observed a *P. princeps* female in South Carolina, occupying approximately the same position facing downward on the main stem near the top of a small (2 meter height) magnolia tree (*Magnolia grandiflora*) over a three day period. This spider was very successful in capturing small leafhoppers that landed nearby, always returning to the stem to feed..

Prey detection (prey sighted per unit time) is also a function of local prey density. If a waiting spider in one location does not sight prey, it may be advantageous for that spider to relocate. Plett (1962a) found that food deprivation led to greater movement by the salticid *Salticus scenicus*. Turnbull (1964) also reported that the theridiid *Achaearanea tepidariorum* would search for a new web site if prey were lacking in one location, and this response to lack of prey is most likely a widespread response of arthropod predators in general.

Individual *P. princeps* with large opisthosomata (an index of the degree of satiation) were observed to remain within or near their resting sacs, near the top of herbaceous plants, throughout the day, in contrast to many *P. princeps* that moved actively during the day, far from any visible resting sacs (Hill 1977). The net effect of this behavior may be to concentrate spiders in areas of high prey density, but the level of activity itself, at least for immature spiders, should also be closely tied to the molt cycle.

Phidippus, like many if not most other salticids, is a diurnal hunter. *Phidippus* that dwell upon herbaceous plants in an open field setting tend to emerge from their resting sacs on suitable days to occupy a series of waiting positions before returning to their resting sac, or constructing a new one, for the night (Hill 1977). These spiders rely on both visual survey from a vantage position for detection of prey at various positions in the surrounding vegetation, and their ability to successfully move to the position of that prey along an available route of access.

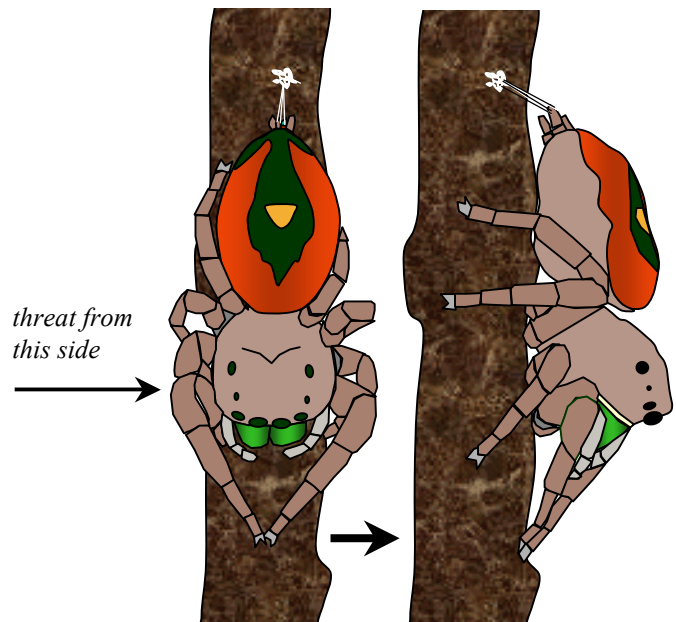

Figure 18. Rapid concealment response by a female *Phidippus pulcherrimus* in a waiting position on a vertical stem. This compares with similar responses by arboreal mammals, such as squirrels. These spiders often rest with legs hooked over the edge of a leaf, facilitating rapid escape from a potential predator. The response shown here was observed for an immature *P. princeps* in the field when a large metallic wasp flew by at a distance of about 1 m. Often sight of a wasp triggered an immediate drop to the ground, sans dragline.

7. Qualitative observations of pursuit by *Phidippus*

Most of the earlier descriptions of salticid predatory behavior involved directed movement of these spiders upon flat surfaces (for example, Homann 1928, Drees 1952, Gardner 1964, 1965, Hollis and Branson 1964, and Forster 1977; see also Figure 18A). Frequently-encountered jumping spiders such as *Playtcriptus*, *Menemerus*, *Plexippus*, and *Salticus* are found on walls or surfaces where a more-or-less direct route of approach to prey may represent the norm.

If a prey insect alights on a flat surface occupied by a waiting *Phidippus*, the spider will turn quickly to face that insect in response to its movement. If an attack follows (presumably based on visual evaluation of the potential prey), the spider may advance directly toward the prey at a variable but steady pace, eventually slowing to a stalk or a slow, leg by leg, advance in a partly crouched position (legs drawn near the body, reducing the apparent size and threat of the predator), with the pedipalps flickering up and down in unison, as if mesmerizing the prey. When a certain proximity is reached, the spider may crouch and prepare to jump by forming an attachment disk for the drag line, and by flexing legs IV, the extension of which will provide the thrust for the jump, against the surface. In the case of *Phidippus*, the spider also raises legs I and II toward the prey, and positions legs III laterally against the surface for support (fulcrum). A sudden extension of legs IV hurtles the spider into the air toward the prey, which is grasped by the legs and bitten with the chelicerae.

General descriptions of this kind may lead to the misconception that they represent the norm of behavior. In fact, the Salticidae is such an ancient and highly varied clade, that one must be careful not to draw conclusions about the entire group based on observation of one or several genera, under limited circumstances. Some salticids (including most *Phidippus* species) can be found on herbaceous plants and rely primarily on extension of legs IV during a jump, but others (including *Habronattus*) are often found on or near the ground, and rely primarily on extension of legs III during a jump. In addition, the method of approach to prey can vary greatly depending on prey characteristics (see Edwards and Jackson 1993).

Most of my own observations of directed movement or pursuit have involved members of the Dendryphantinae (Maddison and Hedin 2003), a large group that includes the genera *Phidippus* and *Eris* in North America. *Phidippus* is a large genus of at least 60 described species (Edwards 2004), and includes many of the largest jumping spiders known. For the present study, species known to inhabit herbaceous plants along forest margins, old fields, and diverse tall grass prairies in North America, were observed. This does not imply that the same species could not be found in other habitats.

If one quietly observes and follows an actively-moving *Phidippus* spider as it travels through the complex tangle of vegetation in an old field or prairie habitat, it soon becomes apparent that these spiders alternate visual observation of their surroundings (facing alternatively in different directions) with rapid movement, often not in a straight line. Very often, it appears that the spider sights a position in the vegetation, and then moves to that position, even if the required movement requires a circuitous detour.

The various experiments described in subsequent sections of this paper follow a common theme related to systematic and repetitive demonstration that the movement of *Phidippus* jumping spiders in vegetation is in fact not random, but constitutes *pursuit*, or directed movement toward a series of sighted objectives. In addition, these experiments will demonstrate the important role of various forms of positional information (relative direction and distance of an objective) available to the spider, and their importance during pursuit. The important role for the identification and the pursuit of *secondary objectives*, defined as positions which support access to the *primary objective* of pursuit, will also be demonstrated. Taken altogether, these capabilities allow the *Phidippus* jumping spider to identify and to follow a fairly circuitous or detoured route through the infinitely varied and complex structures presented by vegetation.

To begin, we will qualitatively review a series of observed predatory pursuits, each stimulated with a *standard lure*, upon various natural plants or artificial structures. Most of these qualitative examples were recorded out of doors, under conditions of natural lighting. These reveal both the general features of, and the relative sophistication of movement through vegetation by these spiders, facts that we should not forget when we proceed subsequently to simplified and repetitive experiments.

A series of pursuits by *Phidippus* on flat vertical or horizontal surfaces are described in Figure 19. Note that this introduces the convention, used in this paper, of depicting each spider stopping position with an open circle, each appearance of a standard lure with a filled circle, and each facing turn or run with an arrow. The simple and readily repeatable demonstrations shown in Figure 19 reveal important features of pursuit that will be examined in more detail below, most notably the *segmented* nature of pursuit, whereby pursuit of a primary objective is broken up into a series of pursuits of sighted secondary objectives, and the use of *reorientation turns* to face the original position of sighted prey after movement away from (not facing) that position.

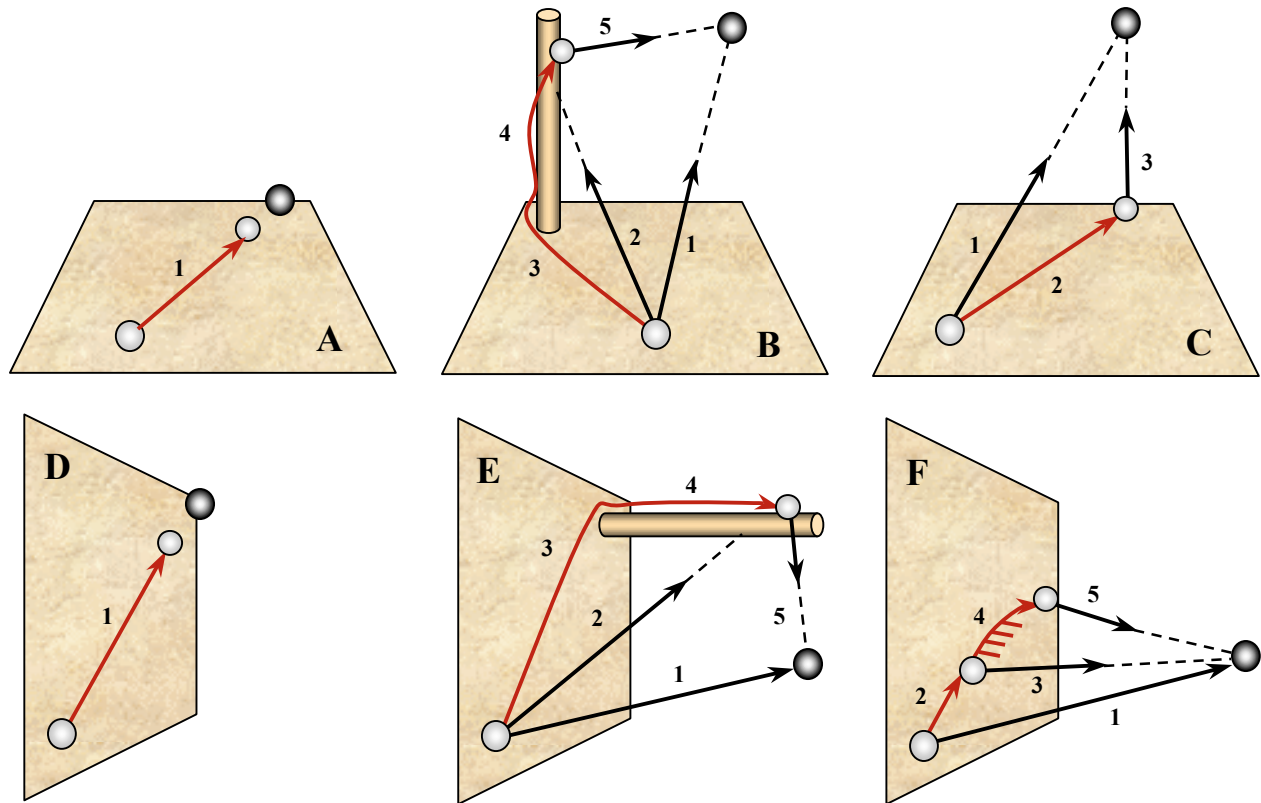

Figure 19. Simple pursuits by *Phidippus* on either horizontal (A-C), or vertical (D-F) plane surfaces. When prey was near the surface (A, D), movement was directly toward the prey. On a vertical surface with no nearby structures (C), a spider moved closer to the elevated prey, and then looked up to the sighted prey position. With the presence of a nearby structure (in this case, a wooden dowel; B, E), spiders turned to face that structure (2), then proceeded to approach (3) and climb it (4) in order to approach the prey position. From this structure, the spiders *reoriented* (5) toward the expected prey position in each case. Note that this structure represented a *secondary objective* (the prey was the *primary objective*) of each pursuit, and this also represents one of many examples of movement *away from the prey* toward a secondary objective. Situation (F) demonstrated the use of gravity by these spiders, in that they moved away from the prey in order to secure a position above the prey from which a predatory jump could be initiated. In this case, spiders would reorient to the prey position (3) and side-step (walk sideways facing the prey; 4) to attain a position above the prey (5). Several experiments below will demonstrate more of this systematic behavior. All of these situations are easy to construct and to demonstrate in a laboratory setting.

One of my earliest sketches of predatory pursuit by a *Phidippus* (in this case *P. princeps* in an old field situation) is shown in Figure 20. Note in particular how this spider reoriented to the prey position (6), and then ran a fairly complicated, uninterrupted route through vegetation, at times moving 180° away from the prey direction, before reorienting from a new position (8).

Figure 21 depicts one of many staged pursuits where a standard lure was used to initiate predatory pursuit, in this case by a female *P. pulcherrimus*. In this case, the spider moved rapidly (2) away from the prey position to climb down to an accessible plant stem, from which it climbed up to the location of the sighted prey. There were no reorientation turns in this case until the spider turned onto the branch where the prey had been (4, 6). This demonstrated that *Phidippus* could run a complicated route without stopping to reorient, and still retain a memory of relative prey position. More often, however, reorientation was observed after a shorter segment of pursuit.

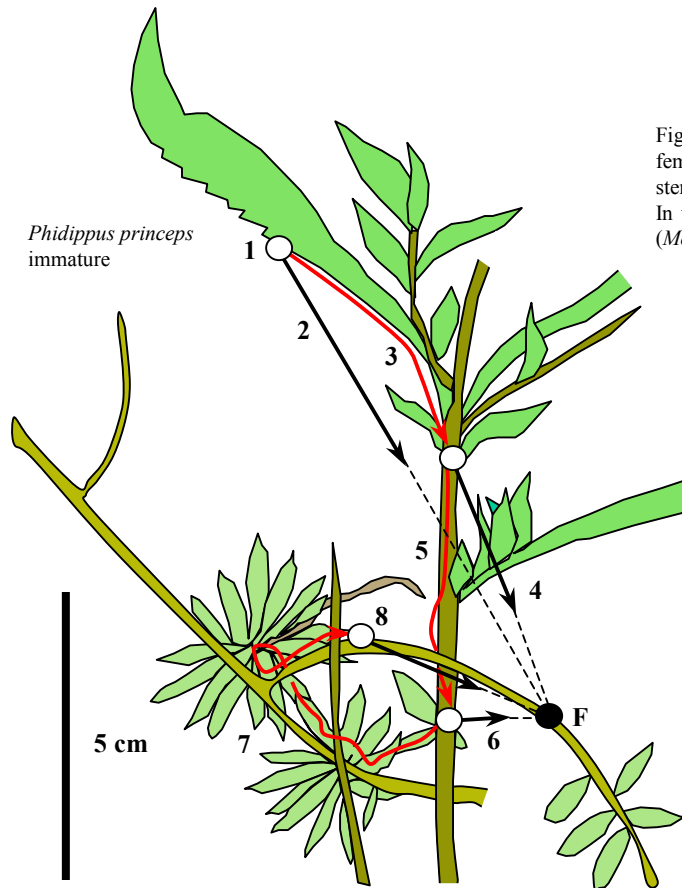

Figure 20. Indirect pursuit of a fly (F) by an immature (5 mm length) *P. princeps*. The spider was resting under a *Solidago* leaf (1), then turned to face a fly (2) when it landed about 10 cm away on a *Euphorbia esula* branch. Pedipalps moved rapidly up and down as the spider faced the fly (2). Subsequently the fly did not move as the spider ran a rapid, circuitous approach route, including three separate stops (4, 6, and 8) for reorientation to the prey position. Note in particular the indirect and circuitous route (7) before the last reorientation position (8) was attained.

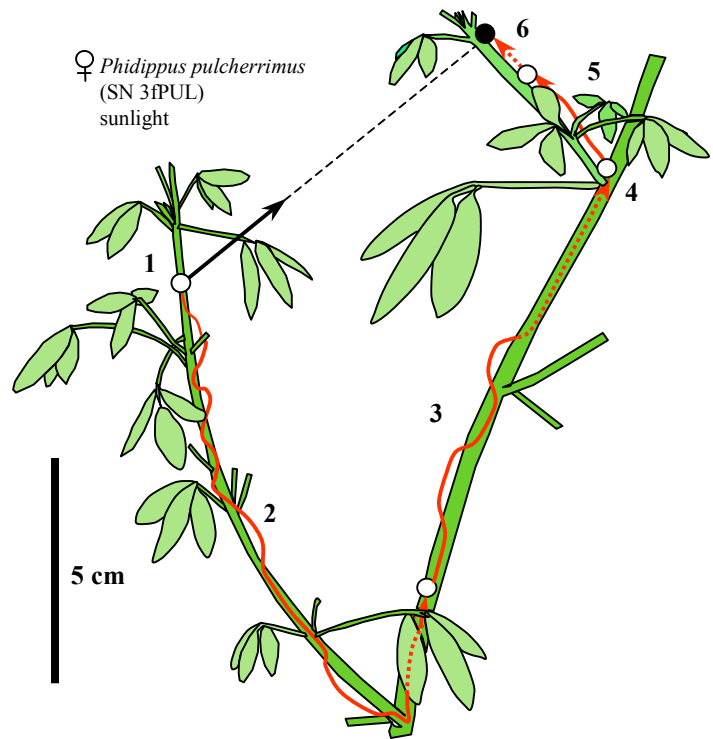

Figure 21. Long route of pursuit without intervening reorientation turns by a female *P. pulcherrimus*. Note that this spider moved around the branch and stem during a long winding descent (2), followed by a long winding ascent (3). In this and similar situations in subsequent figures the plant was sweet clover (*Melilotus alba*).

The next example (Figure 22) was particularly revealing with respect to the use of multiple or serial secondary objectives during predatory pursuit. Note in particular how this spider (a female *P. pulcherrimus*) was able to attain different secondary objectives during the pursuit with direct jumps (3, 7). In this case, as in most examples of staged pursuit shown here, the standard lure was immediately removed at the onset of pursuit to eliminate the possibility of its use by the spider to determine prey position. Use of a jump to a secondary position, after a circuitous back-tracking run, is also shown in Figure 23.

Figure 24 shows how a *P. pulcherrimus* was able to maintain its memory of relative prey position after turning to reach unsuccessfully toward a leaflet (3), and then continuing on its less direct route down the stem (4).

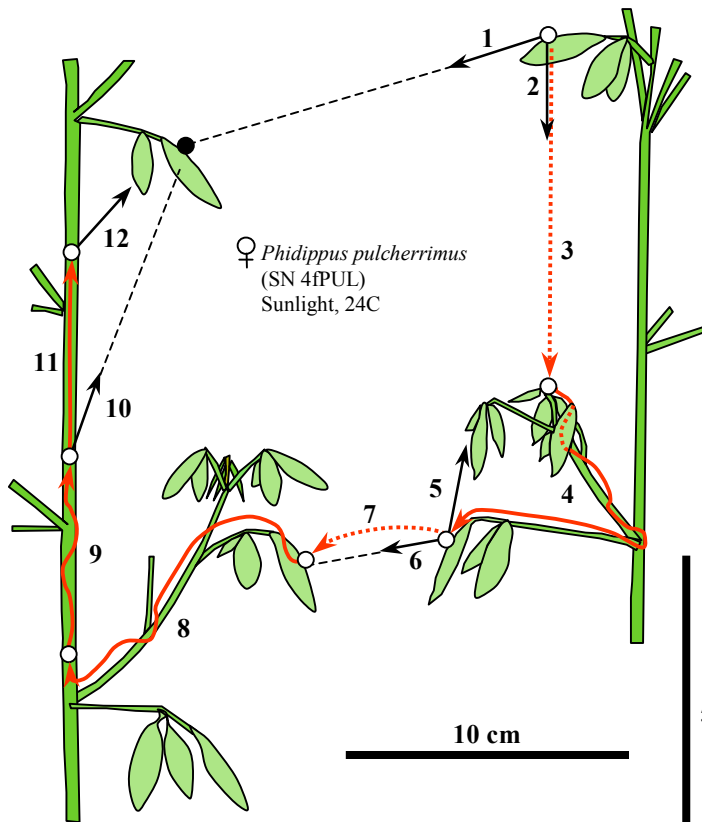

Figure 22. Rapid pursuit by a female *P. pulcherrimus*, showing the use of jumps (3, 7) to attain sighted secondary objectives. The standard lure (filled circle) was removed at the onset of this pursuit. This spider maintained a memory of the sighted prey position (as evidenced by accurate reorientation turns at 10 and 12), even after turning away from the route at (5), before fixing on a leaflet as a secondary objective at (6). The turn down jump shown at (3) was frequently observed in situations like this.

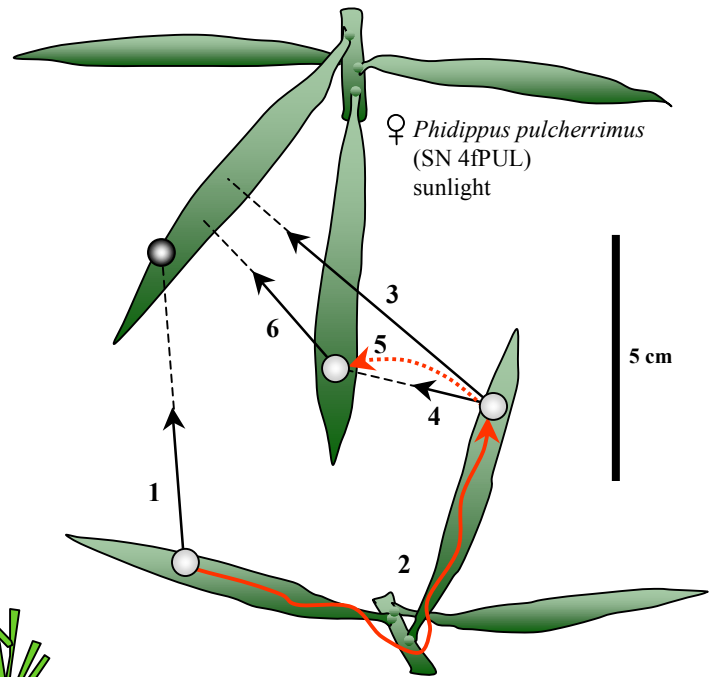

Figure 23. Indirect pursuit of standard lure on *Solidago* by a female *P. pulcherrimus*, viewed from above. Note reorientation turns at (3) and (6), with intervening orientation to a secondary objective (leaf at 4), and a jump to that objective (5). The standard lure (filled circle) was removed at the onset of this pursuit. Note the ability to maintain memory of relative prey position after an uninterrupted and circuitous run away from the prey, from one leaf back to a stem and then out onto another leaf (2).

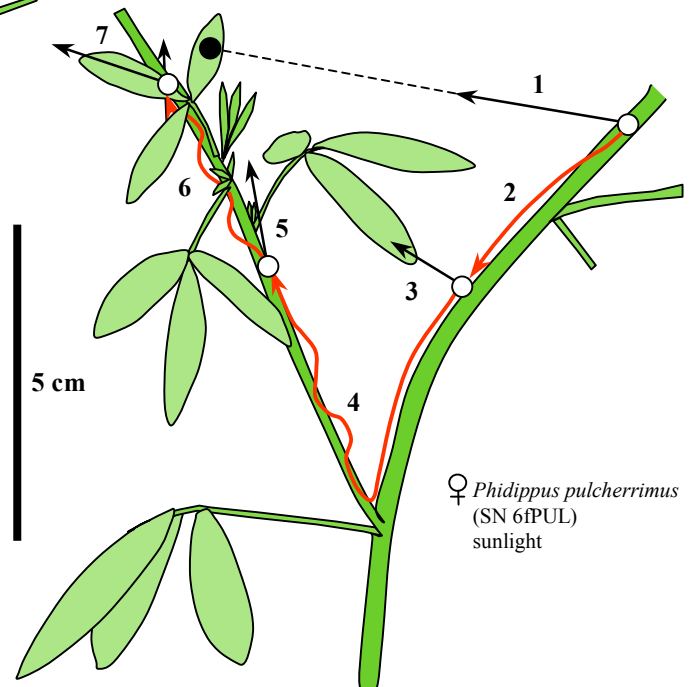

Figure 24. Indirect pursuit of a standard lure (removed at onset) by a female *P. pulcherrimus*. This spider reached out to a leaflet in the prey direction at (3), but did not secure a foothold and then quickly continued on the pursuit with a run down to and then up the branch associated with the prey (4). It stopped near the initial location of the lure (7) and executed facing turns in different directions.

Figures 24 (3) and 25 (3) demonstrate that interruption of a pursuit through a "wrong turn" does not necessarily alter either the objective of that pursuit, or the spider's memory of the relative position of a primary objective (prey). In the pursuit depicted in Figure 25, the spider moved out onto a branch that did not provide access to the stem of the plant, and it successfully back-tracked and continued its pursuit.

The example shown in Figure 26 illustrates the process of actively visual evaluation of the route of approach (turns 7, 8, 10) from a new position attained during the pursuit. This spider elected to go with the shorter jump (sighted by turns 7, 10) rather than a longer jump suggested by turn (8).

Figure 27 presents an example of predatory pursuit by *P. pulcherrimus* that involved execution of both a climb under an existing silk drag line (also shown in Figure 1, B), and a long jump down to the stem associated with the prey. This example suggests that these spiders can associate prey position with specific structures in the vegetation, which can assist in the relocation of that prey after movement, or can also serve as secondary objectives during a pursuit.

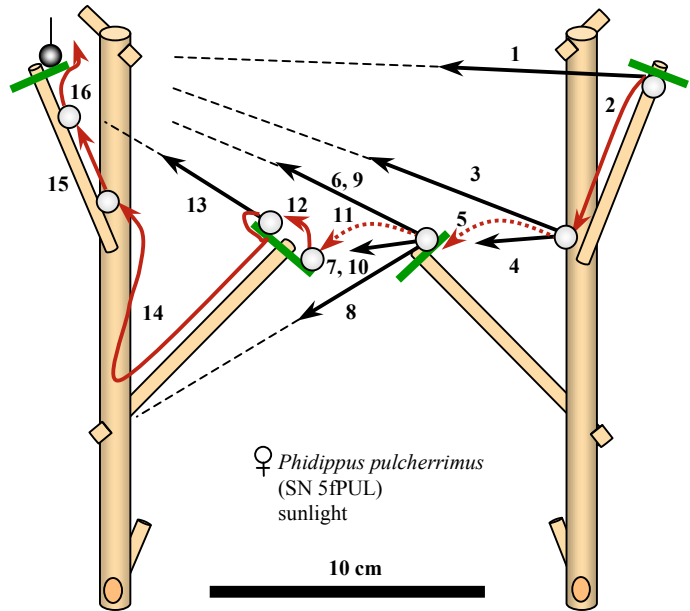

Figure 26. Indirect pursuit of standard lure on an artificial plant, constructed with wood dowels and heavy green paper leaves. This female *P. pulcherrimus* was particularly adept, as most spiders tested on this configuration only got as far as the reorientation turn (9). The lure (upper left) was removed at the onset of pursuit. After this spider jumped to a leaf (5), it made five facing turns toward various structures (6-10), before jumping (11) to a second leaf. Note the frequent reorientation turns to the original prey position (3, 6, 9, 13). This spider walked very quickly to the original prey position with only brief stops (14-16), once it reached the second plant.

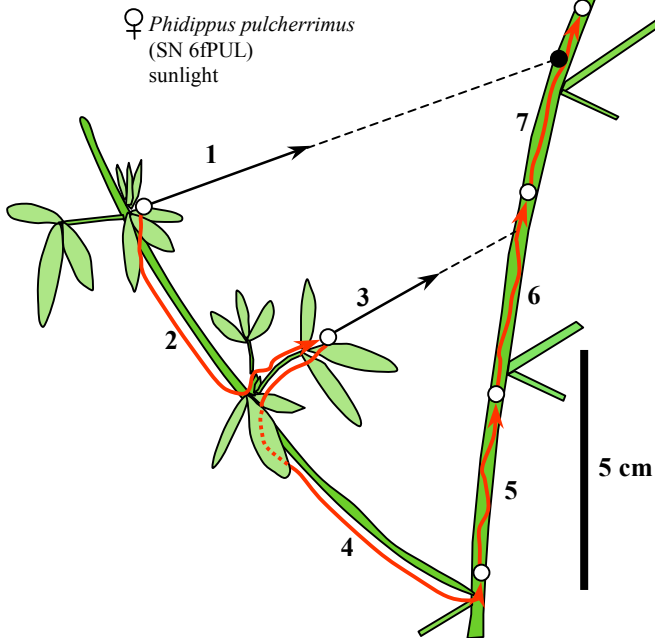

Figure 25. (above) This female *P. pulcherrimus* made a failed approach at position (3), forcing a back-track (4) to continue the pursuit. The fact that this spider continued to face up-stem after reaching the main stem of this plant, and did not turn to look in other directions, suggests that the prey position may have been associated with the stem itself by the spider.

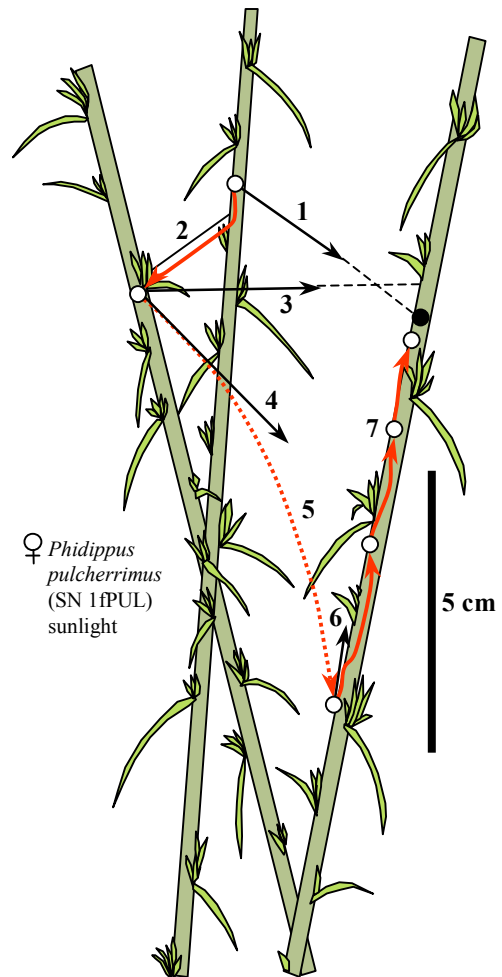

Figure 27. (right) Use of an existing drag line by a female *P. pulcherrimus* during a pursuit. The standard lure (upper right, filled circle) was immediately removed at the onset of pursuit. This spider turned from the prey to climb under an existing drag line (2), then reoriented to the original prey position (3). Then the spider turned down to face the stem associated with the prey, and made a direct, long jump to that stem (5), immediately followed by reorientation to the original prey position (6). This demonstrates the ability of these spiders to maintain a memory of the relative position of prey even after a horizontal climb under a silk line, or after completion of a long jump to attain a secondary objective.

A second example where the spider appeared to associate the prey position with the radial direction of a specific leaf is shown in Figure 28. Figure 29 depicts a female *P. regius* that apparently chose the wrong set of leaflets to pursue, but this behavior also suggests that the spider originally associated the sighted prey with a set of leaflets.

Figure 30 shows how *P. pulcherrimus* could maintain a constant radial alignment with a branch associated with the prey position during a long, uninterrupted descent (4). Note the distance of continuous movement down the stem and then up the branch, prior to reorientation (5).

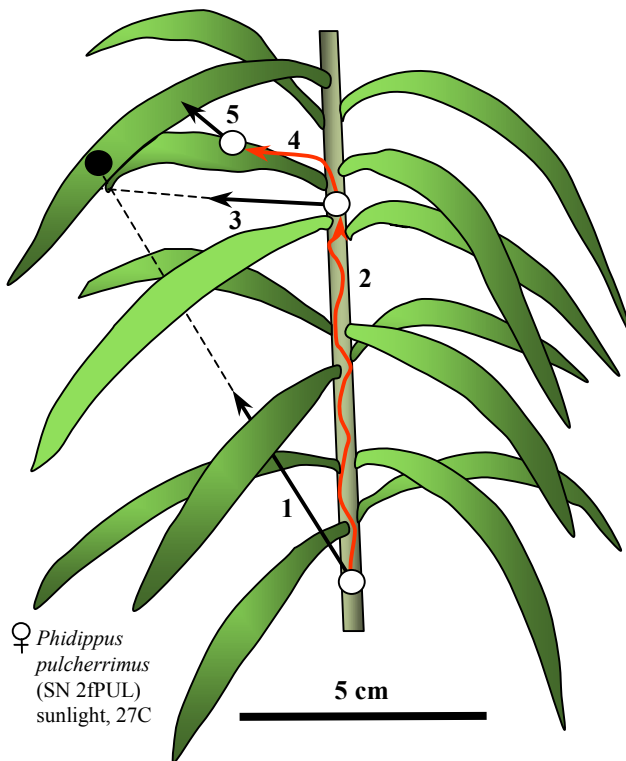

Figure 28. Indirect pursuit of a standard lure by a female *P. pulcherrimus* on *Solidago* (standard lure removed at onset). In this case, leaves radiating from the stem of the plant could provide strong visual cues with respect to radial direction from positions on that stem.

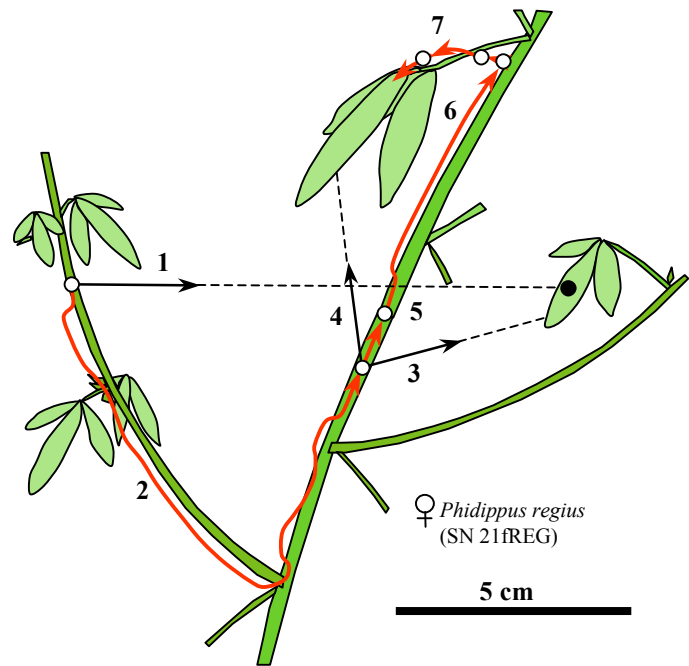

Figure 29. Apparent choice of the wrong objective by a female *P. regius* (standard lure removed at onset). After a long run under a branch (2), this spider turned to look first at the leaflets associated with the original prey position (3; standard lure removed at onset of pursuit). This spider then turned to face a different set of leaflets (4), which it subsequently pursued (5-7). This supports the hypothesis that these spiders can associate discrete plant forms with prey.

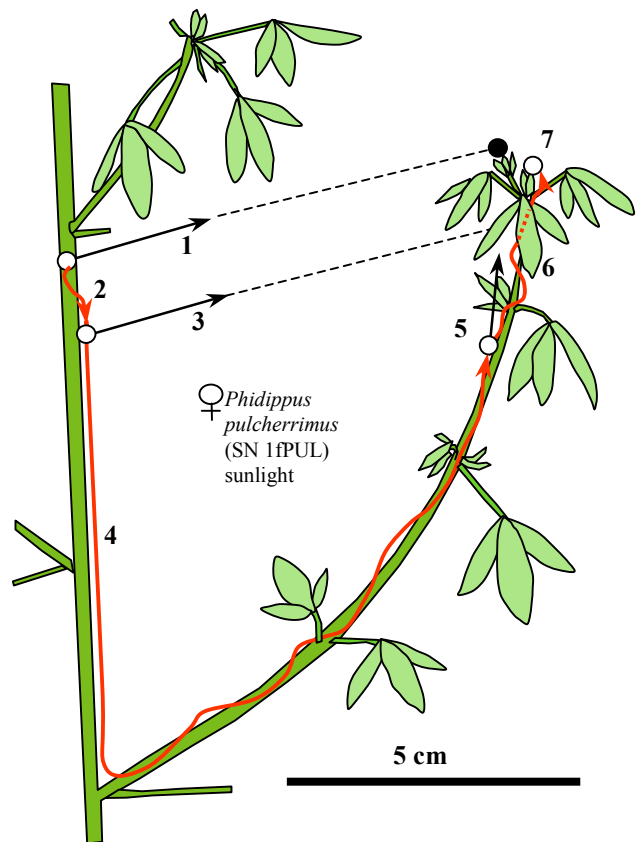

Figure 30. Indirect pursuit by a female *P. pulcherrimus* (standard lure removed at onset). The constant radial orientation of this spider on the stem during a long descent (4) suggests that this spider maintained visual contact with the objective branch.

Figure 31 illustrates a successful *jump down* to the branch associated with the target, after a distinct turn to face that branch (4) after reorientation (3). The spider shown in Figure 32 failed to make a similar jump (6), but nonetheless recovered and found its way back to that branch to continue its pursuit. This ability will be addressed later in our discussion of *jump recovery* experiments.

The example in Figure 33 shows that a *P. regius* could maintain a sense of relative position in the absence of direct visual contact with the objective branch during a long descent underneath a different branch. Continuous visual contact with a plant structure may be useful during pursuit, but it was not required to establish relative position.

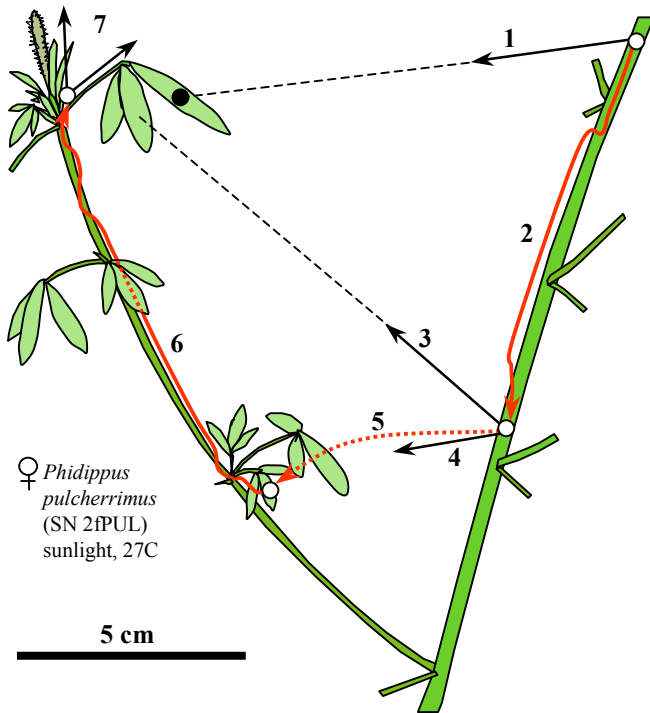

Figure 31. Successful jump to branch by female *P. pulcherrimus* during pursuit of standard lure (removed at onset of pursuit). Note the distinct turn (4) to face the target of the jump directly. By jumping down, as shown here, the spider could obtain a greater range.

Figure 33. (right) Long run under a branch during pursuit of a standard lure (removed at onset) by a female *P. regius*. Note how this spider was able to maintain a sense of position relative to the prey after a long, uninterrupted descent of the branch and subsequent ascent of the stem.

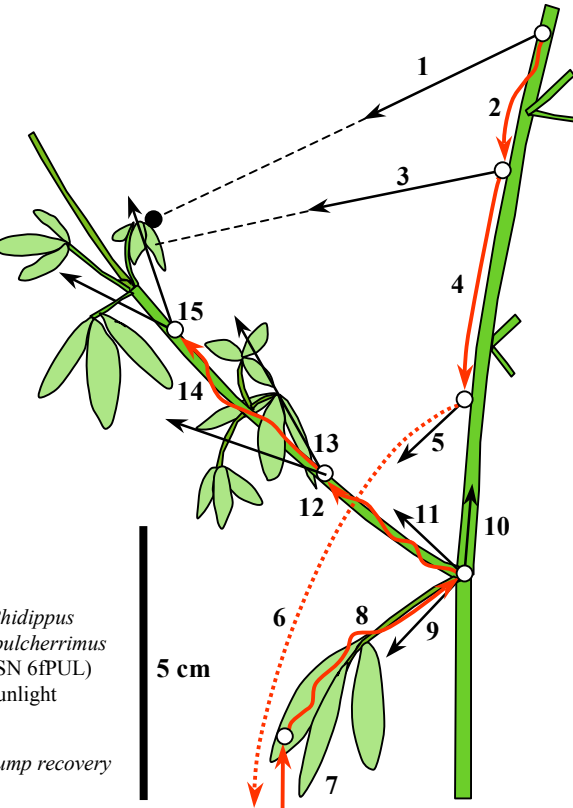
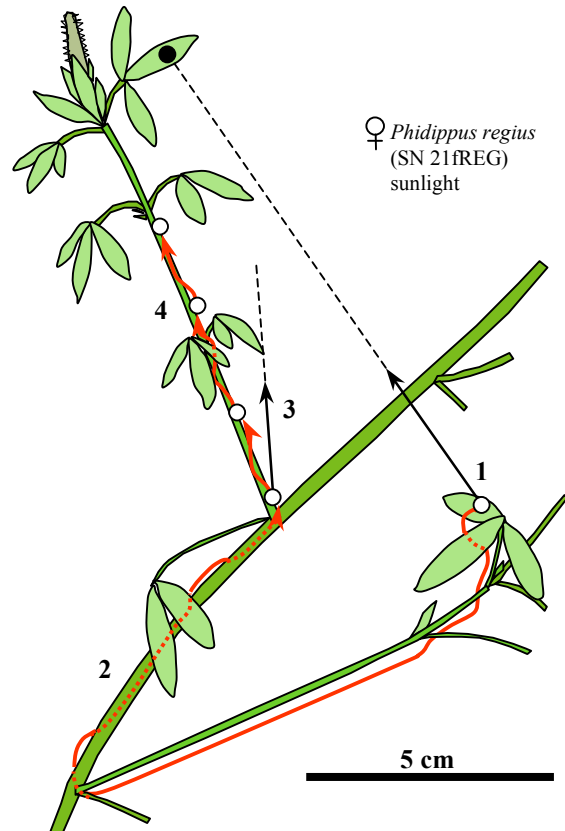

Figure 32. Apparent visual recovery of the objective position after a failed jump during pursuit (standard lure removed at onset). This female *P. pulcherrimus* ran directly toward (4) and then turned to face (5) a branch that could lead it to the target, but missed a jump to it (6). After climbing up the dragline (7) and moving back to the stem (10), the spider stopped and faced each of the three directions associated with plant structures (9-11) before continuing pursuit (12-15) and searching on the branch associated with the original prey position.



A final qualitative example (Figure 34) illustrates the indirect pursuit of a sighted female by a male *P. audax*. This example not only illustrates the use of an indirect route in a different behavioral context, but it also shows how a side-stepping spider engaged in a courtship display could conduct a detoured pursuit while maintaining visual contact (facing) with its target.

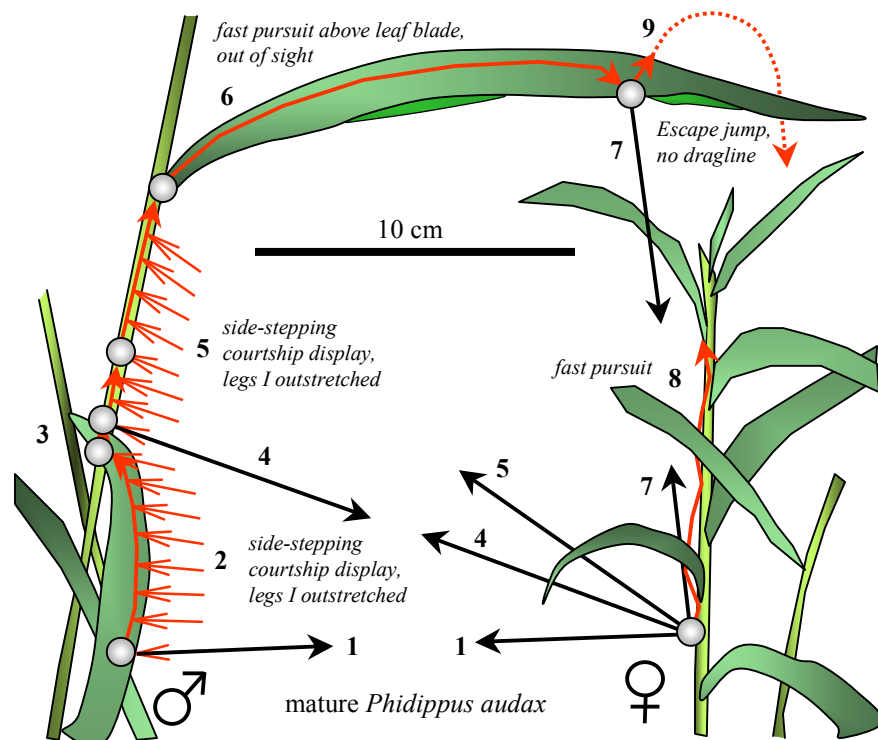

Figure 34. Indirect pursuit of a female *P. audax* by a male of the same species, recorded during the fall of 1977 near Newnan's Lake in Alachua County, Florida. Presumably associated with high prey density, a very high population of these spiders facilitated field observation of behavior. In this example, the male first sighted the female on a separate plant (1, at left), then side-stepped toward a connecting plant while continuing a vigorous visual display with legs I outstretched (2, at left). The male climbed directly to an adjacent stem (3, at left), and continued its side-stepping display (5) as it ascended the stem (5). Note how the female followed the movement of the male (turns 1, 4, and 5 at lower right). The male moved closer to the female on top of a connecting leaf, out of sight of the female (6, at top), then reoriented to the female position (7, top). At this time the female faced the male and ran quickly to pursue it (7, 8 at lower right), presumably as prey. The male promptly jumped off of the connecting leaf to escape this attack (9). This example illustrates the fact that visual courtship display and movement during pursuit are not exclusive activities. It also illustrates (run 6, at top) the ability of these spiders to move toward a position that is out of sight.

8. Selection of a visible access route

In this section, we will review several experiments used to demonstrate the role of a visible access route in determining the immediate direction of pursuit by *Phidippus*. Earlier studies (Kaestner 1950, Dzimirski 1959) have demonstrated that salticids of the genera *Evarcha*, *Heliophanus*, *Marpissa*, *Salticus*, *Sitticus*, and *Synageles* would move toward a striped wall in preference to an unmarked wall in a corridor, so the concept that salticids are sensitive to their visual surroundings is not new. The working hypothesis for this section is as follows:

Phidippus visually identify a plant structure that is physically connected with, or otherwise associated with access to, the objective of their movement. They then move in the direction of that structure as a secondary objective. Movement toward the structure that is identified as a secondary objective generally requires the spider to turn away from, and to move away from, the sighted prey objective (primary objective).

These spiders may set and then utilize multiple serial or further nested (e.g., a tertiary objective could possibly be used to attain a secondary objective) secondary objectives during the course of a single pursuit of a primary objective, allowing them to navigate a detoured approach of considerable complexity. The experiments described here focus on the selection of a secondary objective. There is considerable opportunity for the future study related to the possibility of nested objectives during pursuit by salticid spiders.

Sequential T-maze problem

A simple experiment shown in Figure 35, outside of the context of predatory pursuit, illustrated the ability of *Phidippus* to consistently select a visible route of vertical ascent in order to continue a climb through multiple segments of movement. At each decision point during the climb, this spider turned and faced the respective vertical dowel prior to movement toward it and continued ascent. Curiously, these spiders could also complete this maze in darkness (as viewed by a dim red light) without visual survey at each decision point, but in that case their choice of route (Figure 34A, 3 or 4 at position 2) was apparently random. The presumed objective of the spider during this experiment was generalized ascent.

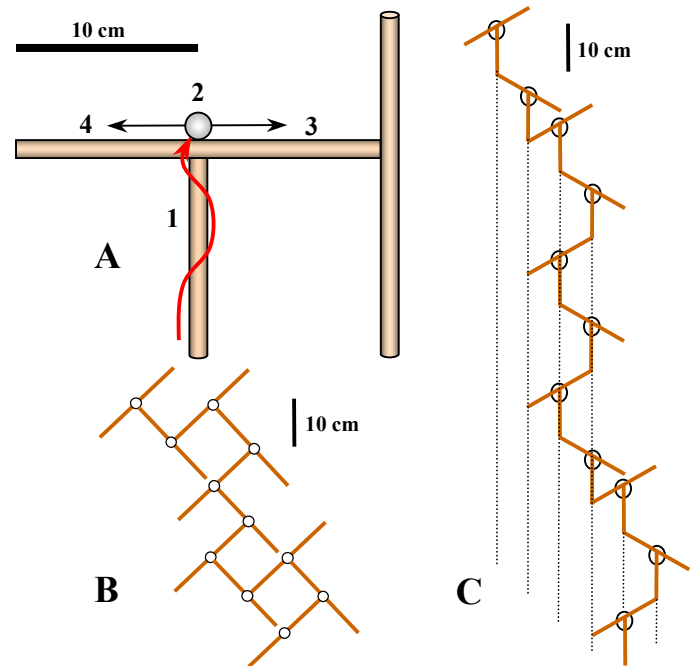

Figure 35. Sequential T-maze problem. The individual T, constructed of wood dowels, is shown in (A). The spider ascended to a decision point (2), then moved either toward the visible route of ascent (3; vertical dowel), or in the opposite direction (4). The complete structure, shown in both horizontal plane projection (B) and lateral perspective (C), provided 10 sequential decision points for the ascending spider. Each decision point occurred at a level 10cm above the level of the preceding decision point. In a total of 10 ascents on this structure, a single male *P. pulcherrimus* (SN 7mPUL) moved in direction (3) as indicated in (A) in 97 of 100 choices ($P < 0.001$). In all trials this spider completed a steady walk to the top of the structure. Pauses for visual survey always occurred at the decision points (open circle). The same individual completed a run to the top of this structure in the dark (as observed with faint red illumination from below), but in this case only 4 of 10 of its initial decisions were directed toward the route of ascent, and there was no pause for visual survey prior to a decision. In all trials spiders walked on top of the horizontal bars.

Up or down access decision

This experiment (Figures 36-38) presented each spider (either *P. pulcherrimus* or *P. regius*) with the option of moving either down (configuration A) or up (symmetrical configuration B) to utilize a visible route of access. The results (Figure 38) indicated unambiguously that the decisions of these spiders were based on the relative direction of a visible connecting branch (*secondary objective*) that provided access to the target. This was true, even though in most cases (particularly when an ascent was required) the spiders did not turn to face the connecting route prior to their run toward it. This suggests that the visual image of the connection as identified with the *lateral eyes* may be sufficient to direct movement of the spider toward a connection. Several examples of the behavior of individual spiders on this apparatus are depicted in Figure 37. Some spiders consistently failed to face the access route before turning and moving toward it. Others (Figure 37D) had a distinctive tendency to move on the concealed side of the stem, away from the prey or target position.

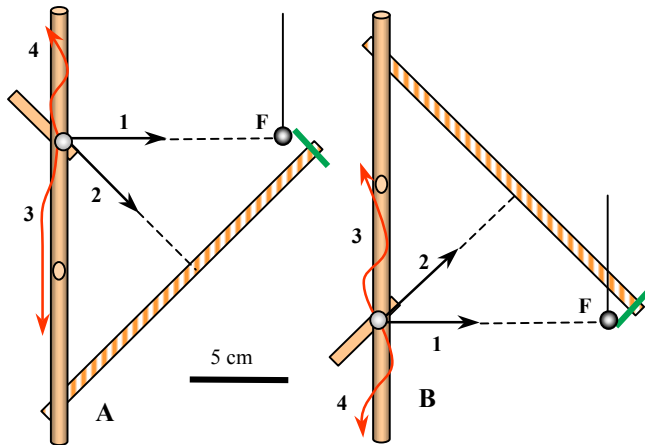

Figure 36. Demonstration of the role of vision in the determination of a route of pursuit, irrespective of gravity. Each problem was repeated at a series of positions on an artificial plant constructed of wood dowels and small posterboard squares at the end of each “branch.” Both problems (A) and (B) began with presentation of the standard lure (hanging dead fly, F) to the spider as shown. The spider (open circle on main stem) immediately turned to the fly (1) to initiate each trial. The relative position of the prey was in a horizontal direction perpendicular to the main stem on which the spider rested in both problems. The only difference between the two problems was that the branch that provided a visible connection or route to the prey position was below the spider in (A), and above the spider in (B). Prior to each trial, the spider was lured to the starting position with the standard lure. Recorded results for both problems included the number of trials in which a distinct orientation to face the visible connection (2) took place, the number of trials in which the spider moved along the main stem toward the visible connection (3), and the number of trials in which the spider moved away from the visible connection (4). If vision were a significant determinant of the direction of pursuit, one would expect event (3) to occur significantly more than (4), in both cases. This agrees with the actual results (Figure 38).

Figure 38. (right) Results for access problems (A) and (B) as presented in Figure 36. The numbered column headings correspond to events described in Figure 36. Both *P. pulcherrimus* (PUL) and *P. regius* (REG) were observed. Clearly, as shown by χ^2 analysis of these counts (column at right), the decision to either ascend or to descend was based primarily on the relative position of the visible access route, or secondary objective.

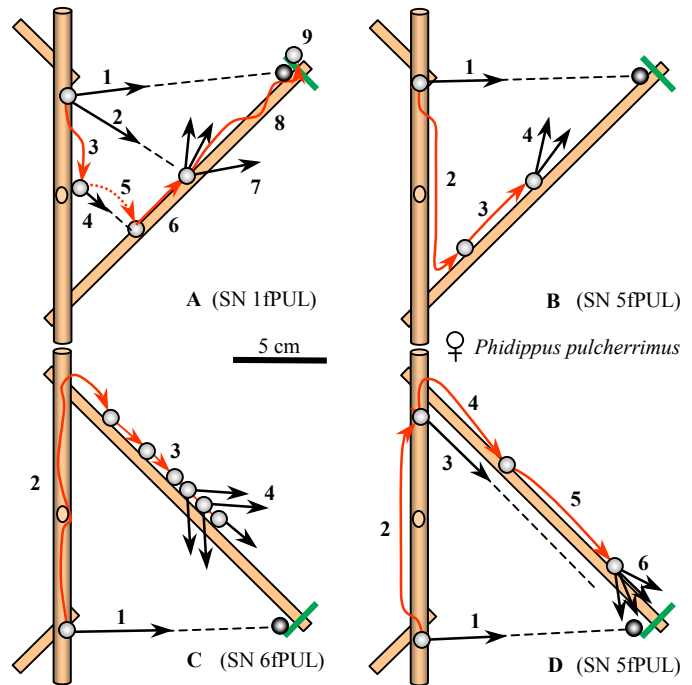

Figure 37. Some different approaches utilized by individual spiders to solve the problems of access presented in Figure 35. In each case the standard lure (fly) was removed quickly with no visible impact on the spider as soon as the spider turned away from its initial orientation to run a pursuit. Thus the subsequent pursuit was not dependent on a continuing prey stimulus. A: The spider turned to face the prey (1), turned down to face the access route (2), ran down on the side of the stem facing the access route (3), turned to face the access route (4), jumped to it (5), ascended (6), stopped for a series of small turns (7), ascended (8), and finally (9) reached and explored the apical region of the branch. B: Typically for this individual, the initial orientation (1) was followed by a rapid walk (2) directly toward the access route, followed by ascent (3), and small turns (4). C: After the turn to face the target (1), this spider walked rapidly up to the access route (2), then made a halting descent along that route, followed by a series of turns (4). D: The initial facing turn to prey was followed by a slow walk on the side of the stem opposite to the prey direction, reorientation (3), and then descent (4, 5) along the access route followed by a series of small turns (6).

SN	N	[2] turn to route	[3] run to route	[4] run from route	P([3]=[4])
<i>Problem A: DESCENT required for access to target</i>					
1fPUL	30	19	29	1	<<0.001
3fPUL	22	16	20	2	<<0.001
5fPUL	20	2	22	0	<<0.001
7fPUL	4	1	4	0	---
total PUL	76	38	73	3	<<0.001
22fREG	40	31	33	7	<<0.001
24fREG	15	14	15	0	<<0.001
total REG	55	45	48	7	<<0.001
<i>Problem B: ASCENT required for access to target</i>					
1fPUL	22	10	22	0	<<0.001
3fPUL	32	13	32	0	<<0.001
4fPUL	6	0	6	0	---
5fPUL	38	5	38	0	<<0.001
6fPUL	22	3	22	0	<<0.001
total PUL	120	31	120	0	<<0.001
22fREG	44	1	44	0	<<0.001
24fREG	64	3	64	0	<<0.001
Total REG	108	4	108	0	<<0.001

Circle of plants in a horizontal plane

This simple experiment (Figure 39) allowed spiders to move freely around a circle of “plants” (constructed with heavy green cardboard rectangles skewered on vertical wooden dowels. Here all movement took place in a horizontal plane, and the choice was between movement in the direction where a visible link to the target position could be seen (3), and the opposite direction (4). For the most part spider trials alternated between left (A) and right (B) configurations of this problem, and resultant data were pooled. As in the preceding experiment, distinct turns to face the visible section that completed the the access route in one of the two directions (2) were also recorded.

In this experiment, the *P. pulcherrimus* spiders that were tested turned to face the visible section that completed the route in almost every trial (Figure 40). One of the *P. regius* did this most of the time, and the other one almost never did it, even though this spider almost always ran in the direction of the completed access route.

The significance of this experiment lies in the fact that the immediate position allowed symmetric movement in either direction (left or right), and it was only the visibly present or missing section of the route that determined the subsequent behavior of the spider. The consistent facing behavior demonstrated by most of these spiders (directly turning and facing the visibly present section, whether to the right or to the left) provides strong evidence that this visual connection was the factor that determined not only the specific direction of this facing turn (2), but also their subsequent direction of movement.

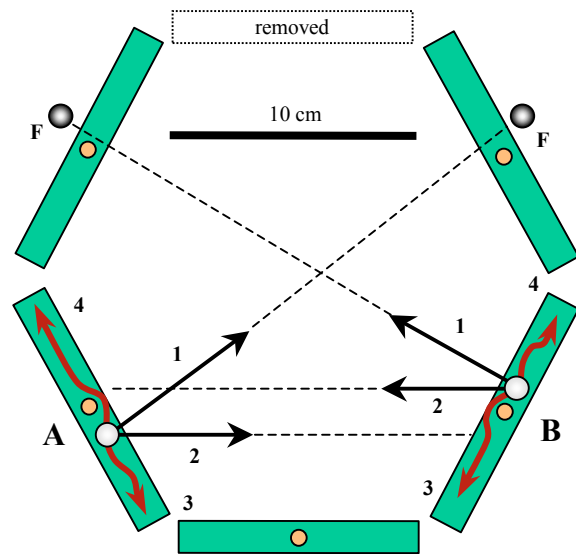

Figure 39. Demonstration of the visual selection of an access route on a “circle of plants” in a horizontal plane, as viewed from above. Each long rectangle was a green paper “leaf,” skewered and supported at the center by a long vertical wood dowel (“stem”). Problems (A) and (B) were run alternately for spiders, for the most part. In each trial first turned (1) to face the prey (standard lure). As in the preceding experiment, distinct turns (2) toward the connecting segment of the access route, and the subsequent direction of movement by the spider (3, toward the connecting segment, or 4, away from it) were recorded. the hypothesis of visual selection of the access route requires that (3) takes place considerably more often than (4). Results shown in Table 3 were consistent with this hypothesis.

SN	N	[2] turn to route	[3] run to route	[4] run from route	P([3]=[4])
1fPUL	24	22	24	0	<<0.001
3fPUL	37	24	37	0	<<0.001
5fPUL	5	5	5	0	---
total PUL	66	51	66	0	<<0.001
22fREG	70	45	41	10	<<0.001
23fREG	42	3	15	1	<<0.001
total REG	112	48	101	11	<<0.001

Figure 40. Results for the problems of access presented in Figure 39. Since a comparable number of trials were run for each of the two mirror-image problems described in Figure 39, with no significant difference in the results, data for configurations (A) and (B) were pooled in this table. The numbered column headings correspond to events described in Figure 39. Individuals of both species (*P. pulcherrimus* or PUL and *P. regius* or REG) demonstrated a highly significant tendency to move in the direction of the visible route of access. Most individuals made a distinct turn (2) to face the visible connection before turning to run the pursuit, in most of their trials.

Connecting link below the plane of pursuit

With the apparatus described in Figure 41, spiders were required to choose between movement to the left and right, as in the previous experiment. In this case, however, the direction of the visible connecting link was below the plane of the spider and the target, and it was either to the left (configuration B) or to the right (configuration C) of the spider, relative to the direction of the sighted objective (standard lure). Pursuit would require movement away from the lure in both the horizontal and vertical planes, and the connecting link did not have a simple, linear relationship to the positions of spider and target.

Similar results for the two configurations were pooled and these are presented in Figure 42. One remarkable feature seen in the results for this problem was that the *P. pulcherrimus* spiders that were tested never missed the turn (2) to face the connecting section, whether this was to the left or to the right. The *P. regius* were also more consistent in this respect than they were in previous problems. A reasonable hypothesis for this result would be that the relative complexity of this kind of visible connection (also related to the relative complexity of movement out of the immediate plane of pursuit to utilize this connection) required more detailed visual evaluation of the entire visible configuration.

Rules determining the direction of pursuit

For a substantial majority of the access problems presented to various *Phidippus* during the course of this study, the spiders used the most direct route of access to the prey that was visible. One might think that a considerable amount of insight would be required to solve some of these access problems, but it is possible to explain this efficiency with a simple evaluation of the constraints in the spider's choice of a direction of movement upon a plant. A stem, for example, allows only two directions of movement. A simple rule for behavior for choosing a direction of movement on a stem during the pursuit of prey would be: Move in the direction which forms an acute angle with the direction of the prey (or target). This basic rule is an effective predictor of the behavior of *Phidippus* on a simple, isolated runway, or on a simple, isolated branch. In these situations compliance with this simple rule leads the spider to the closest possible approach to that prey. However, this rule is clearly violated by the spider in more complex situations that are depicted here (for examples see Figures 22 and 37). In these situations the spiders were forced to move away from the prey or target position during pursuit.

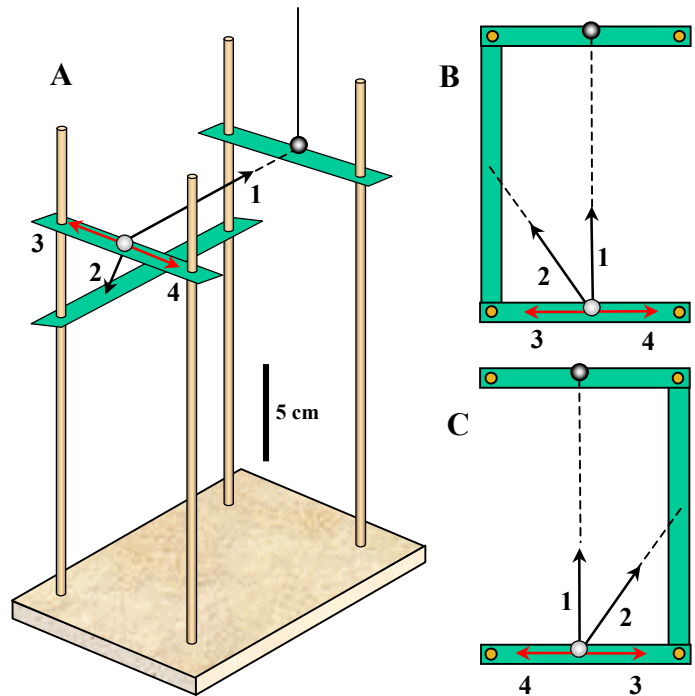

Figure 41. Problem of access requiring the use of a connection which was removed from the horizontal plane defined by the immediate route of the spider and the prey position. This problem is depicted in perspective (A), and also in left-handed (B) and right-handed (C) configurations, viewed from above. As with the preceding problems, turns directed toward the connecting route (2), as well as the direction of movement (3 or 4) from the starting position (open circle) after the spider faced the prey (1), were recorded for each trial. Since data obtained for each of the two configurations were similar for each of the spiders, these results were pooled (figure 42).

SN	N	[2] turn to route	[3] run to route	[4] run from route	P([3]=[4])
1fPUL	41	41	41	0	<<0.001
3fPUL	40	40	40	0	<<0.001
total PUL	81	81	81	0	<<0.001
22fREG	38	30	34	4	<<0.001
25mREG	40	34	35	5	<<0.001
total REG	78	64	69	9	<<0.001

Figure 42. Results for the problem of access in three dimensions described in Figure 41. Numbered column headings correspond to events described in Figure 41. Each spider displayed not only a significant tendency to move in the direction determined by the visible connecting route, but also a significant tendency to turn directly toward that connection most of the time before pursuit. Each turn to face the connecting route (2) was quite distinct. The two female *P. pulcherrimus* repeatedly ran the problem in either direction like clockwork, never missing a distinct turn toward the connecting route prior to pursuit. This was somewhat different from the results of the two preceding experiments, where such turns were often omitted by the same individuals. In this problem, however, the connection between the access route and the immediate route was more complicated. All of the visible features required for solution of this problem were not coplanar.

These apparent violations of the *acute angle rule* might be reconciled to a modified version of that rule, if we incorporate the concept and role of *secondary objectives* into our model. We can start with the assumption that movement of the spider on any route of pursuit is intended to bring it closer to an *immediate objective*. This may be a visible branch or twig that is connected or otherwise associated with (e.g., it may provide elevation required for a successful jump) access to the target position. When it substitutes this branch or twig (a secondary objective) for the target (primary objective) as the immediate objective of pursuit, the spider moves in a manner that brings it closer to the secondary objective, but not necessarily closer to the primary objective. Our modified rule may be stated as a hypothesis as follows: *Move in a direction, afforded by the immediate route, which forms an acute angle with the direction of the immediate objective.*

We can define a *segment* of pursuit to include all movement toward a secondary objective. Thus a single pursuit may utilize a number of successive secondary objectives. The ability of *Phidippus* and other salticid spiders to solve a complicated problem of access is, in part, the result of its ability to substitute intervening, secondary objectives for the primary objective, as determinants of immediate behavior.

Clearly these spiders must retain a *memory* or *internal representation of location* of the primary objective as they conduct an indirect pursuit, even as they are running over to a stem or jumping to a nearby plant. This representation must be updated as the spider moves, and it must be retained along with the basic context of pursuit, even when the spider pursues intervening or secondary objectives along the way. The nature of this representation will be studied in subsequent sections of this report.

During a jump to a nearby plant (e.g., Figure 30), the plant itself is the immediate objective (secondary objective). For the leaf-litter salticid *Anasaitis canosa*, a sighted branch lying horizontally on the ground can be pursued as an immediate objective, which in turn facilitates rapid movement toward a sighted prey position (Hill 2006b).

Clearly salticid spiders use their remarkable vision to evaluate and to select an immediate or secondary route of pursuit, and they can utilize additional information obtained as they move through vegetation to modify this route of pursuit. There are two key questions impacting this *evaluation process* that deserve our attention. The first can be stated as follows: What kind of objects (or feature sets) does a spider *recognize*, from its working set of internal concepts about the surrounding environment? A salticid obviously treats a dragline as something different from a blade of grass, and a vertical stem may be recognized as something quite different from a branch or a leaf.

The second question pertains to the location of a secondary objective relative to the primary objective: What kind of *relationships between objects* does the spider recognize and respond to, again from its working set of internal concepts?

Since time is a critical factor when *Phidippus* pursue flies (although not necessarily when they pursue other insects), it is possible that each spider simply moves toward the first intervening objective that is sighted, provided that it meets certain criteria. The experiments described here (Figures 39-42) show that these spiders can visually discriminate between a complete, or more complete, visual connection to the target position, and a broken or interrupted connection.

Concealed approach can also be a factor in the movement of a pursuing *Phidippus*, even if it does not determine the general direction of pursuit. Figures 25, 29, and 33 depict situations where *Phidippus* spiders ran quickly along the underside of a branch, out of view. Some the individuals tested in experimental situations reported in other sections of this report consistently ran on the side of a branch or stem away from the sighted prey.

Figure 27 depicted the sequential use of a dragline, a long jump, and a running ascent up a stem, in the course of a single circuitous pursuit. In this example (as in Figure 1), the connecting dragline (which was already in place) may not have been seen by the spider, but was detected upon contact and rapidly used during the pursuit. All features that may provide access during a pursuit may not be seen by the spider in advance. Although these may facilitate movement, they may not be secondary or intervening objectives in themselves. The tendency of these spiders to move toward elevated positions that facilitate predatory jumps to a target position (seen in Figure 19E-F) will be investigated in a subsequent section of this paper.

The hypothesis that these spiders can use multiple *nested objectives* during the pursuit of a prey or target position is of interest. This would require the simultaneous use of at least *tertiary objectives*, in addition to the primary objective and the secondary objectives. Just as the secondary objective facilitates access to the primary objective, the tertiary objective would facilitate access to the secondary objective. Consider the example shown in Figure 41. The spiders faced (2) and moved toward the connecting link which could be described as a secondary objective, but to reach this link they had to move toward and then climb down a connecting vertical dowel. This vertical structure could be viewed as a tertiary objective.

As one more example that supports the hypothesis of nested objectives, consider the pursuit depicted in Figure 33. In this case the spider quickly climbed down through the leaves at the end of a branch, to reach that branch, and then rapidly ran under that branch to reach and to climb the main stem of the plant without interruption until it reached another branch associated with the target. If the branch associated with the target was in fact the secondary objective at the onset of this pursuit, then the main stem of the plant could be a tertiary objective, and the other branch first reached by the spider could even be a quaternary objective.

This hypothesis of *multiple nested objectives* (beyond the primary and secondary levels), particularly as it might also relate to the ability of these spiders to establish and to reset objectives during pursuit, clearly deserves more study.

9. Route-referent memory of location

Of all of the potential references that might be employed by *Phidippus* to determine a relative location or a direction in space, the orientation of the body axis itself is most immediate. When these spiders complete *facing turns*, as described previously, they are in effect using the orientation of the prosoma in space (as this corresponds to the positions of the eyes affixed to the carapace relative to their respective visual fields) as a reference direction for the execution of an appropriate directed turn. The *immediate route* of the spider can also provide a very useful reference direction during the pursuit of prey, and this is often much more stable than the orientation of the prosoma itself. The *immediate route* (for example, a branch or stem) is not only a *visible* direction reference for the spider, but it can also be *touched*. The significance of this *touch*, or *contact*, could be seen when the spider ran quickly along a stem in the dark (Figure 35). In practice, it was not possible to separate the components of touch, vision, and body orientation with respect to most of the experiments described in this section. Here the term *route-referent orientation* is used in a general sense to describe the ability of these spiders to remember directions relative to their direction on an immediate route of movement.

This choice of terminology is consistent with the ability (demonstrated in this section) of these spiders to use the *distance of movement* along a route in combination with the *direction of a target relative to that route of movement* to calculate the expected location of that target from a new location.

The general approach, and set of measurements used in these route-referent experiments, are reviewed in Figure 43. As a working convention, all directions with respect to the direction of a route are labeled as θ , and route-referent orientation is also referred to as θ orientation.

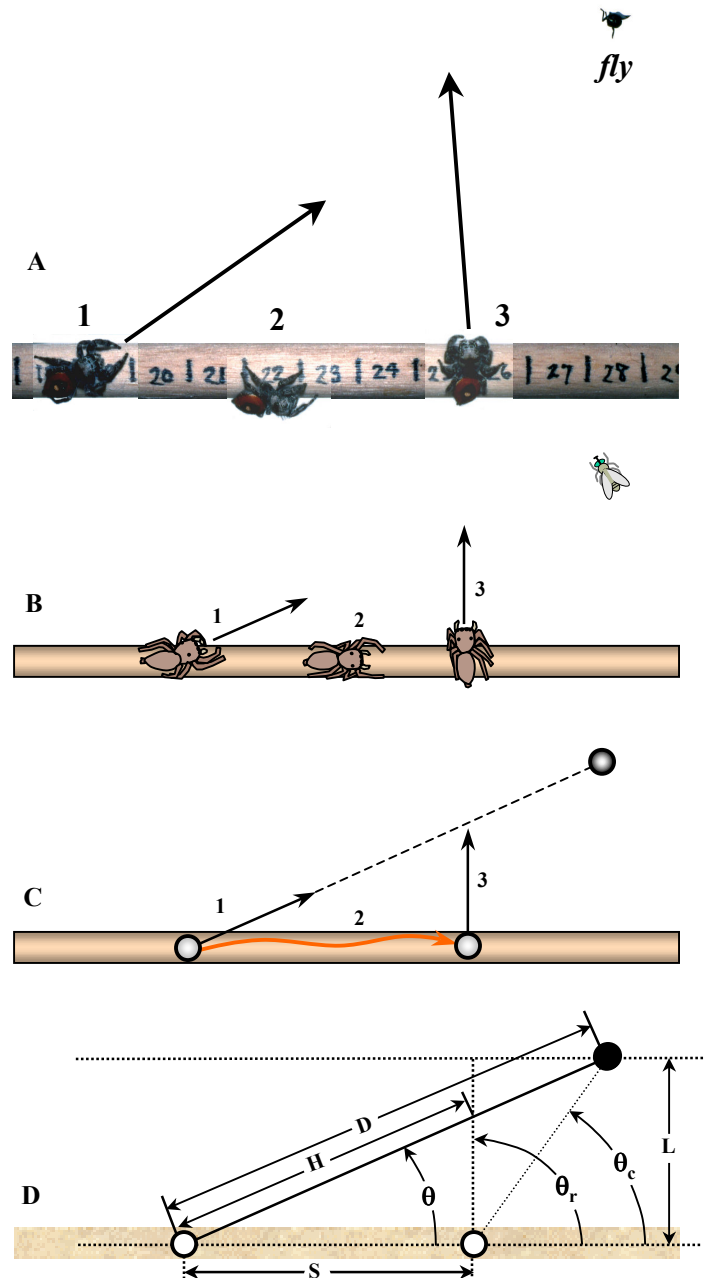

Figure 43. Conventions used to describe and to measure movement during a segment of pursuit on a wooden dowel (bar). At top (A) is a photomontage of an actual pursuit by a female *P. pulcherrimus*. Note how spiders often moved along the bar (2) on the side away from the sighted prey. The same segment of pursuit is depicted as a line drawing (B), a symbolic or schematic diagram (C), and an analytical diagram (D). In each trial the spider turned to face the prey (fly, or standard lure) (1), turned away to run a *segment* of pursuit (2), and then *reoriented* to face the expected position of the prey. In each trial, the standard lure (solid circle) was moved out of the view of the spider as soon as it turned to run the pursuit. (D) shows the measurements taken from each trial: direction of the target relative to the route (θ), the observed direction of reorientation relative to the route (θ_r), the calculated direction of reorientation that would bring the spider to face the original prey position directly (θ_c), the distance of the prey or target (D), the distance of movement of the spider along the route (S), and the distance between the prey and the route of access (L). (H) was interpreted as the distance estimate of the spider as it reoriented, a function of θ , S, and θ_r .

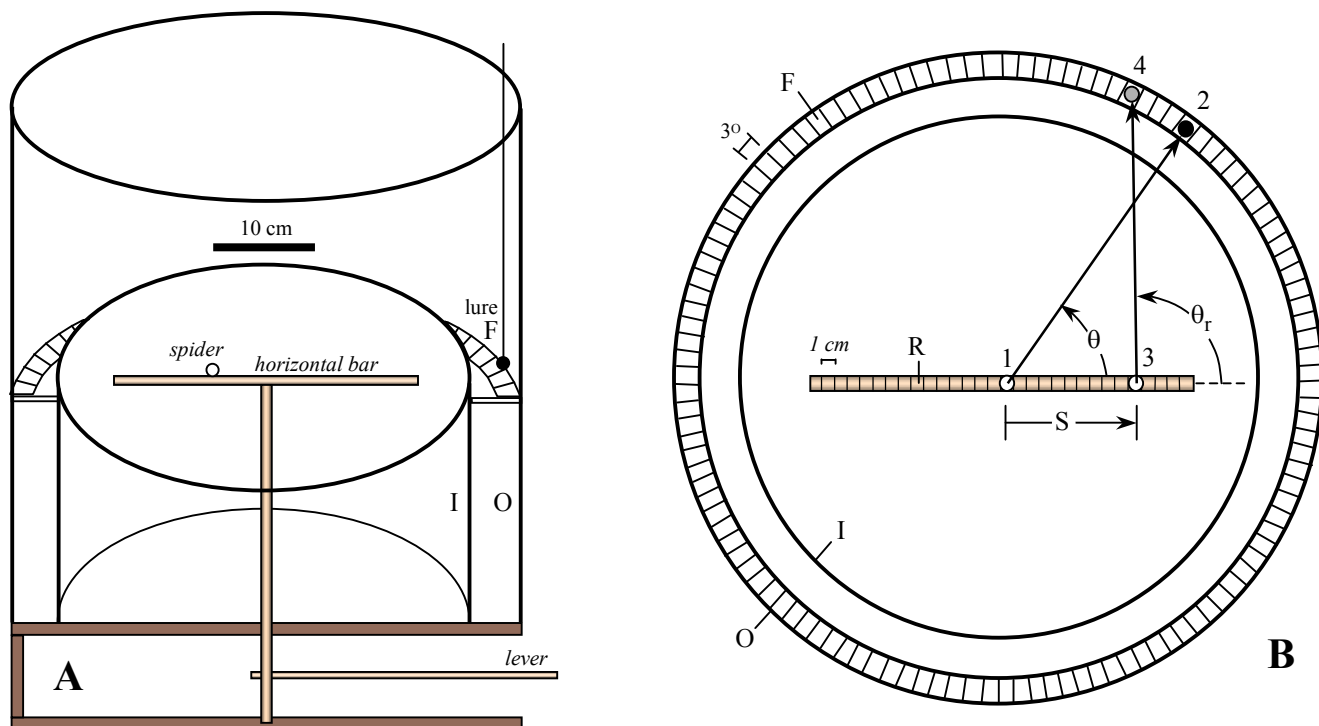

Figure 44. Apparatus used to measure route-referent pursuit behavior on a horizontal bar. A: Vertical section and perspective of the apparatus. The spider (represented by the open circle) ran on the horizontal bar (a wooden dowel) at the center of a large cylinder constructed of heavy white cardboard. Note the use of outer (O) and inner (I) cylinders. A lever (at bottom) permitted rotation of the horizontal bar in a horizontal plane during pursuit. The standard lure (F) was dropped into a trough between the two cylinders as soon as the spider began its pursuit, so that it could not be used as a visual reference for reorientation. A hanging tungsten incandescent lamp was centered above the apparatus. The top of the horizontal bar was level with the top of the inner cylinder. B: Horizontal bar within inner (I) and outer (O) cylinders, as viewed from above. Prior to each trial, the spider was led to the center position (1) on the horizontal bar with the standard lure, to maintain a constant prey distance at the initial sighting. The prey (standard lure) was presented to the spider in a circumferential position (2), and then dropped out of sight as soon as the spider began its run to a new position (3) on the horizontal bar, to reorient in the direction of position (4) on the circumferential (F) scale. The observer read values 1-4 from the R and F scales in sequence while looking down from above, assisted by a thin rod attached to one end of the hair that held the standard lure. This thin rod could be aligned with the facing direction of the spider to assist in the estimate of position (4), which required the most critical attention. Running (R) and circumferential (F) scales were divided into 1.0 cm and 3° units, respectively, as shown here. From values 1-4, θ , S , and θ_r were determined, and θ_c was calculated, as explained in Figure 43. This apparatus allowed presentation of prey to spiders at a range of different values ranging from 0° to 90° , as defined by the acute angle θ .

To study this route-referent orientation on a horizontal bar, the apparatus described in Figure 44 was constructed. The bar was enclosed in a uniform white cylinder, designed to eliminate most visual cues (other than the route itself) that could be used by the spider to determine direction. In the horizontal plane, gravity would also be of no use to determine direction.

Results of this experiment for three different species of *Phidippus* are presented in Figures 45-48. When I first ran this kind of experiment, I naively expected to find that the spiders turned in the correct direction (to the left or to the right), but I did not expect to find the high degree of correlation between the initial target direction (θ) and reorientation direction (θ_r) that was actually observed. In addition, the reorientation direction was consistently greater than the initial target direction. Finally, the correlation between the calculated target direction (θ_c) and the reorientation was even greater (θ_r), strongly supporting the hypothesis that these spiders were actively compensating for the distance and direction of their movement during pursuit, to calculate the direction of the reorientation turn.

In interpreting these results, it is important to note that the entire *horizontal plane of pursuit* in this experiment was defined by both the force of gravity, and the visual image of the surrounding cylinder. All initial orientation and reorientation turns took place within this horizontal plane. As will be discussed in a later section of this paper, at least two complementary reference systems are usually required to establish a direction in three-dimensional space (e.g., how high, and how far to the right or left). For this experiment, the horizontal reference system was held constant, and the only variable was the direction to the right or left in this horizontal plane.

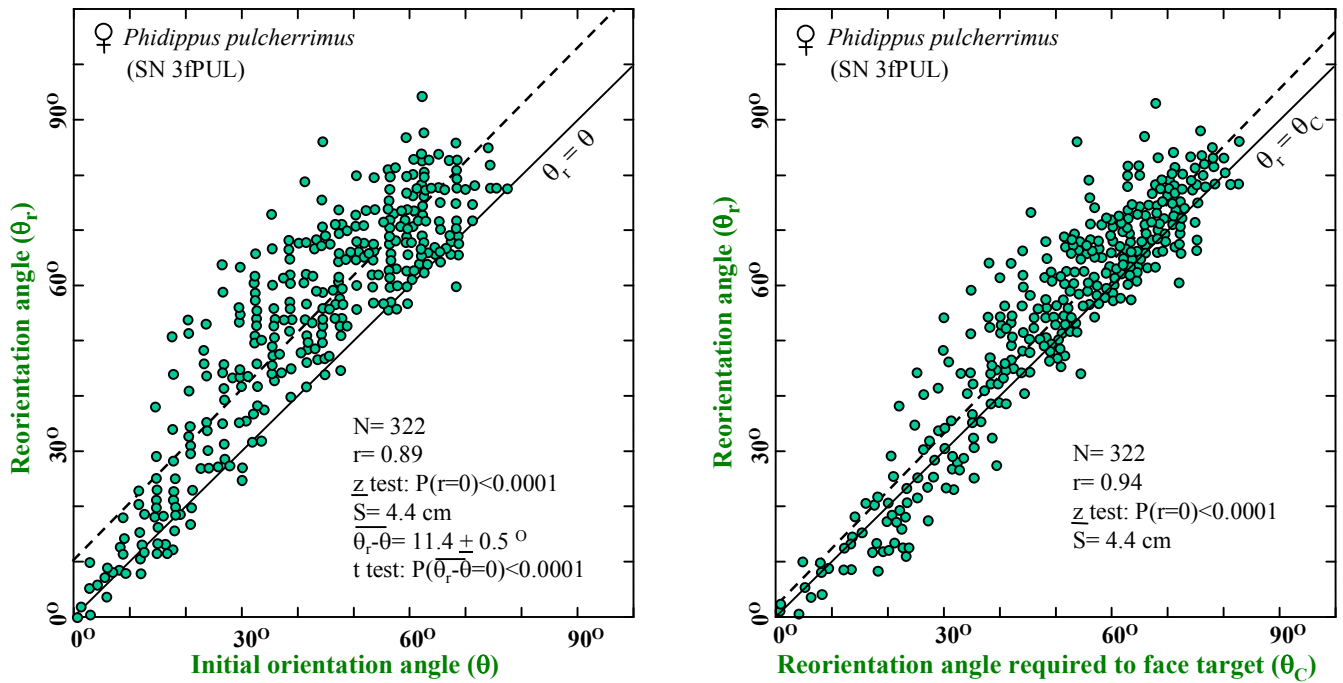

Figure 45. Reorientation behavior of a female *P. pulcherrimus* on the horizontal bar. As in all of the subsequent examples, the reorientation angle was significantly greater than, but highly correlated with, the initial orientation angle (left). The correlation and agreement between the reorientation angle required to face the original prey position and the the actual reorientation angle was even greater (right). In this and in subsequent figures, the linear regression of Y on X is shown as a dashed line, and the Y=X line is shown as a solid line for reference. Note the average pursuit distance of 4.4 cm for this spider.

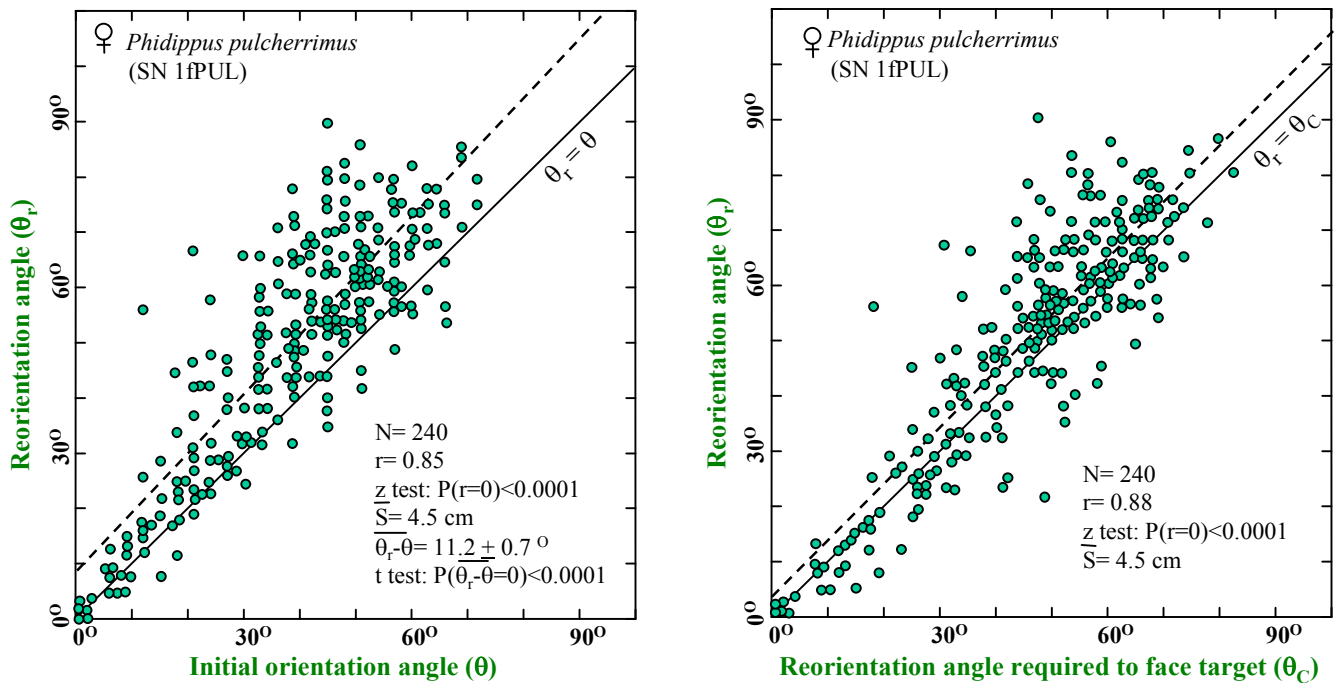

Figure 46. Reorientation behavior of a different female *P. pulcherrimus* on the horizontal bar.

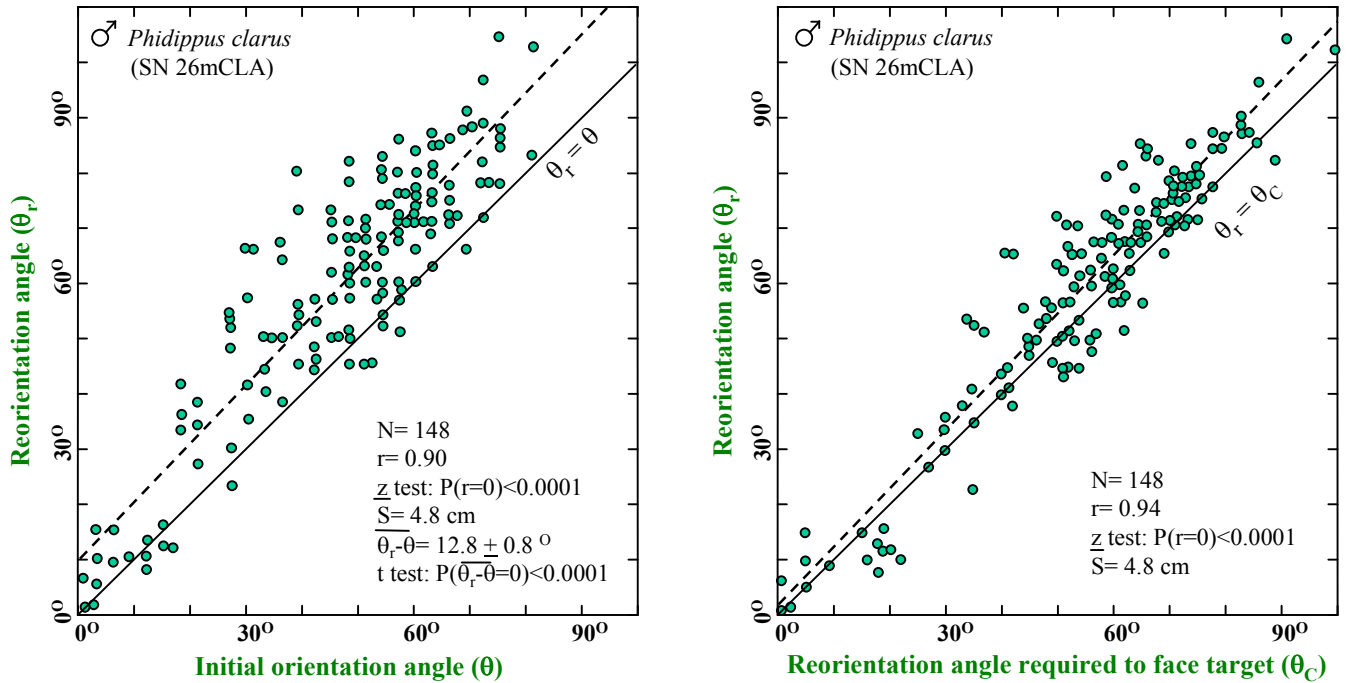

Figure 47. Reorientation behavior of a male *P. clarus* on the horizontal bar. Several of the reorientation turns by this spider exceeded 90°.

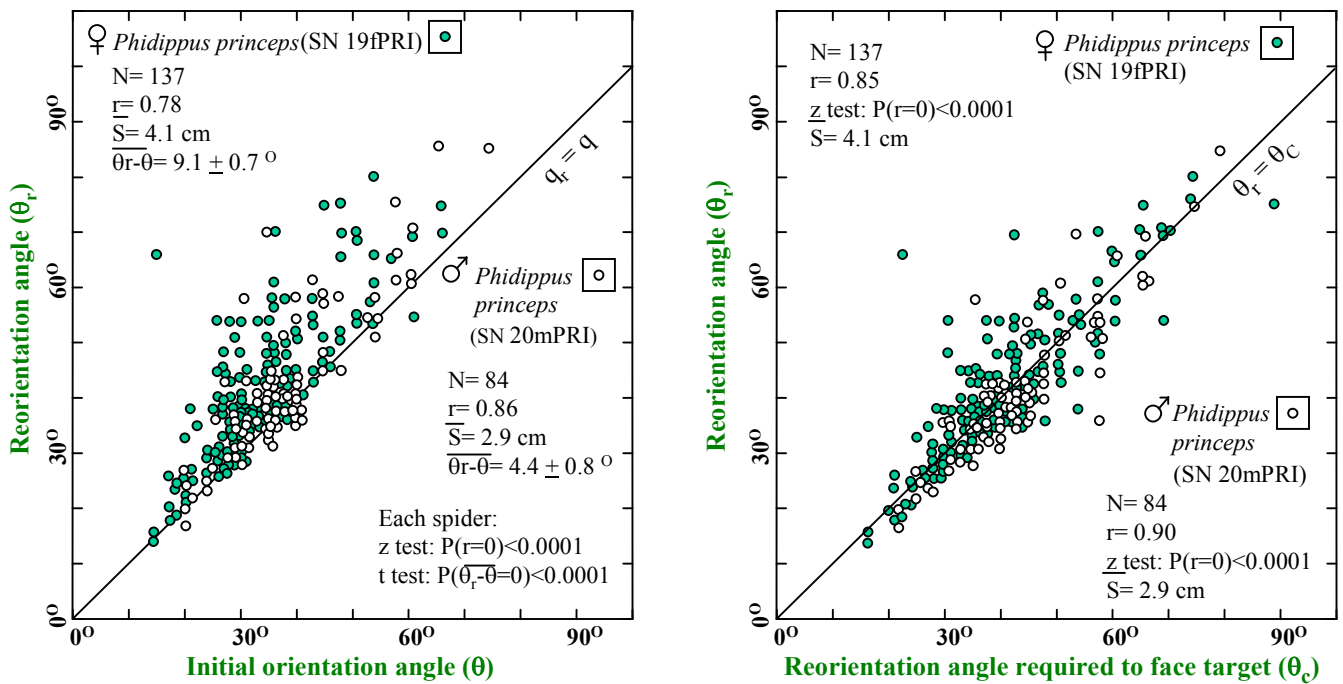

Figure 48. Reorientation behavior of a female (filled circles) and a male (open circles) *P. princeps* on the horizontal bar. These data were collected on the modified horizontal bar shown in Figure 55.

To further eliminate the possibility that visual cues in the surrounding room were used by the spiders, the same horizontal bar experiments were run with a $\pm 90^\circ$ rotation of the bar in a horizontal plane, during the spider's run and prior to its reorientation. The outer cylinder was removed during this experiment to give the spider a clear view of features in the surrounding room. Related measurements on the horizontal bar are explained in Figure 49.

Results (Figures 50 and 51) support the hypothesis that the spider used the immediate route of movement as a reference direction for reorientation. If the spiders were using cues from the surrounding room, outside of the apparatus, they would have reoriented toward the opposite side of the bar, as shown in Figure 49. This did not happen. The somewhat lower correlation between the calculated and the observed reorientation directions may have been the result of the acceleration or vibration of the moving spider during rotation.

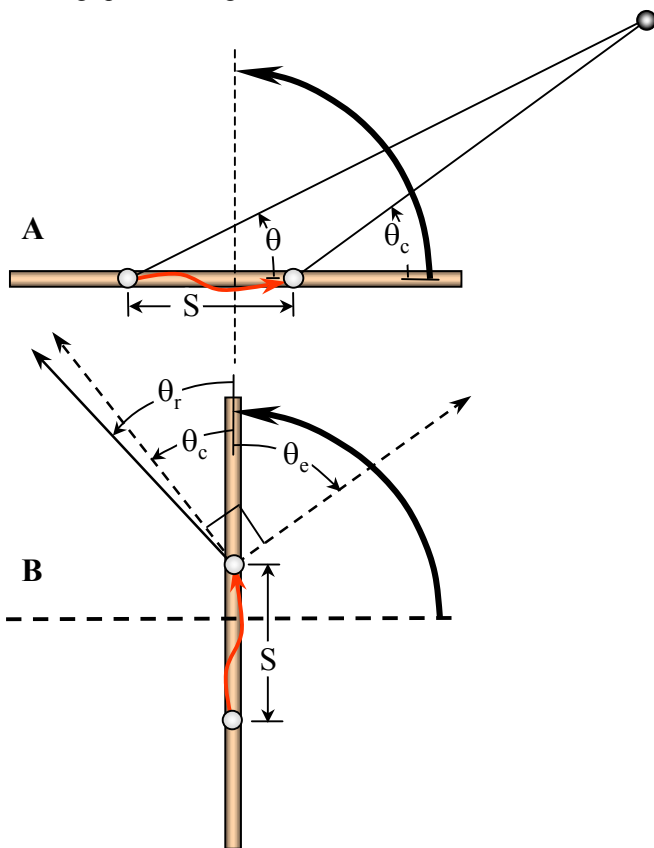

Figure 49. Horizontal bar before (A) and after (B) a $+90^\circ$ rotation in the horizontal plane, as viewed from above. Rotation took place during the pursuit run of magnitude S. (A) follows conventions shown in Figure 43. In (B), dashed vectors indicate two possible directions of reorientation. If the spider used cues external to the apparatus, it could be expected to reorient in the direction indicated by θ_e after rotation (corresponding to the direction indicated by θ_c in A). Instead, spiders consistently reoriented in the direction indicated by θ_c in B, to the same side of the bar as the initial orientation. The outer cylinder for this apparatus (O, Figure 44) was removed during this experiment, to allow the spider to see and to use any visual patterns that might be available in the surrounding room.

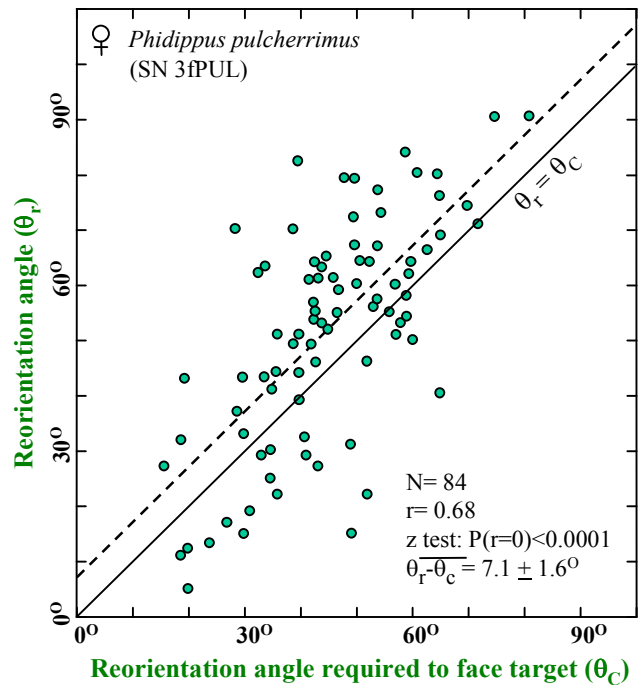

Figure 50. Reorientation by a female *P. pulcherrimus* after a 90° rotation of the horizontal bar during pursuit. This spider consistently directed every reorientation toward the same side of the bar as the initial orientation. Trials were run in two configurations, with the initial target located either to the right, or to the left of the bar as seen from above.

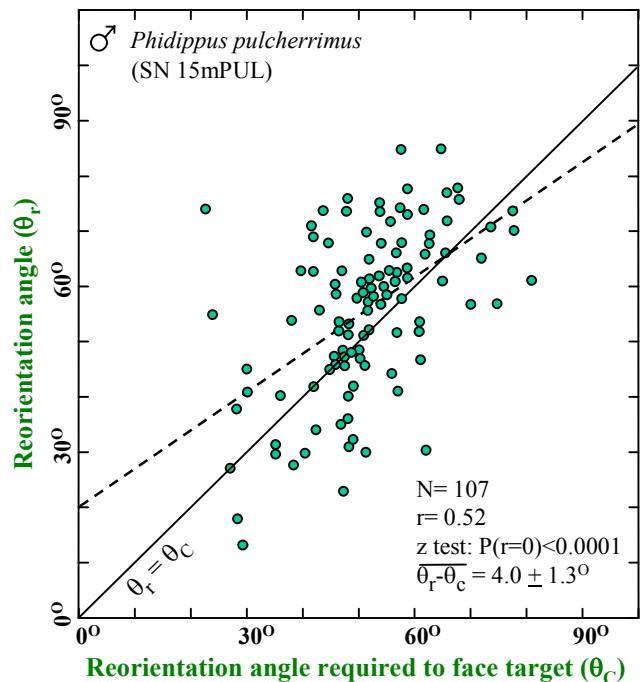

Figure 51. Reorientation by a male *P. pulcherrimus* after a 90° rotation of the horizontal bar during pursuit. As in Figure 50, all reorientation turns were directed to the same side of the bar as the initial orientation to the target, and these trials were run with the target situated either to the left, or to the right, of the bar.

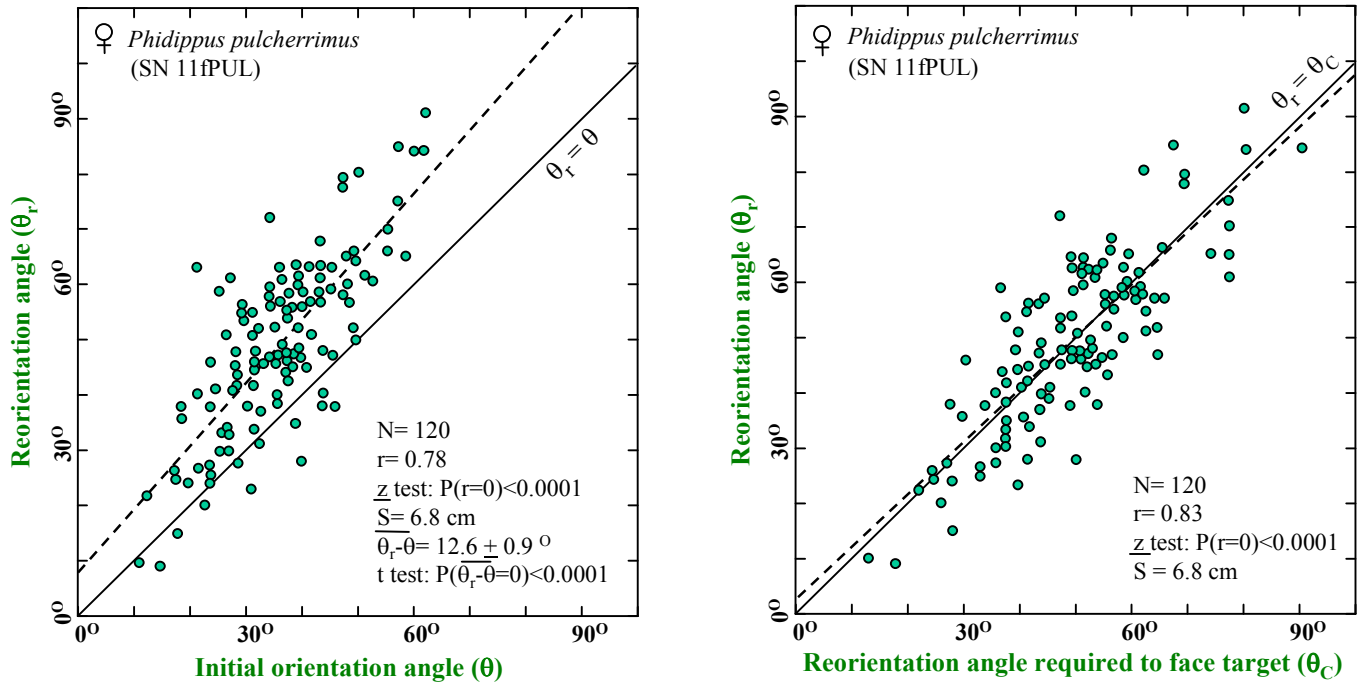

Figure 52. Reorientation turns completed on the horizontal bar in complete darkness, by a female *P. pulcherrimus*. In each case, the overhead light was switched off as soon as the spider turned to run its pursuit. Completion of these trials was facilitated by the fact that this individual tended to make relatively long runs (average 6.8 cm in this case) prior to reorientation. Only trials in which the reorientation turn had been executed completely prior to the time that the light was switched on again were recorded. Trials where the spider waited for the light to be turned on were not recorded. In one of the trials shown above, this spider was already preparing to jump in the prey direction at the time that the light was switched on. In all respects these results compare with those obtained during continuous illumination. This shows clearly that route-referent orientation did not require vision.

To further explore the possible use of visual cues by the spider during these experiments, the same horizontal bar experiment was modified, so that all lights were turned off at the time that the spider turned to run its pursuit, and most of the run and the entire reorientation turn took place in complete darkness.

Spiders were able to complete pursuit runs followed by accurate reorientation turns in complete darkness (see example in Figure 52). This experimental modification provided a definitive demonstration that a visual reference system was not required either as a reference for determination of direction in the horizontal plane, or even for definition of that horizontal plane. This result supports the hypothesis that route-referent orientation is primarily based on the position and movement of the spider itself (internal idiothetic cues, or path integration), and the mechanism may be very closely related to the facing turns (turns in place) that were discussed previously. The hypothesis that the force of gravity (as opposed to visual cues) was the major reference used to define a horizontal plane in these experiments is also supported. This agrees with the earlier observation (Figure 35) that these spiders could maintain a position on top of a horizontal dowel during movement in the dark.

For trials shown in Figure 53, both first and second reorientation turns were recorded. On the average, this spider ran 8.0 cm prior to the first reorientation turn, then ran another 2.4 cm before completing the second turn.

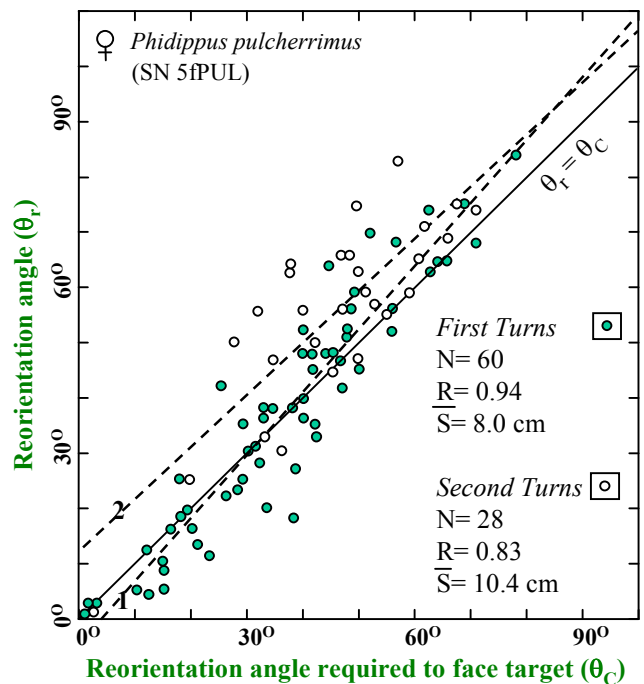

Figure 53. First and second reorientation turns completed by a female *P. pulcherrimus* in response to a single stimulus per trial. The correlation of the second turns with the required reorientation angle was quite good. The second turns (linear regression line 2) tended to be larger than the first turns (line 1), and also tended to overshoot the position of the original target.

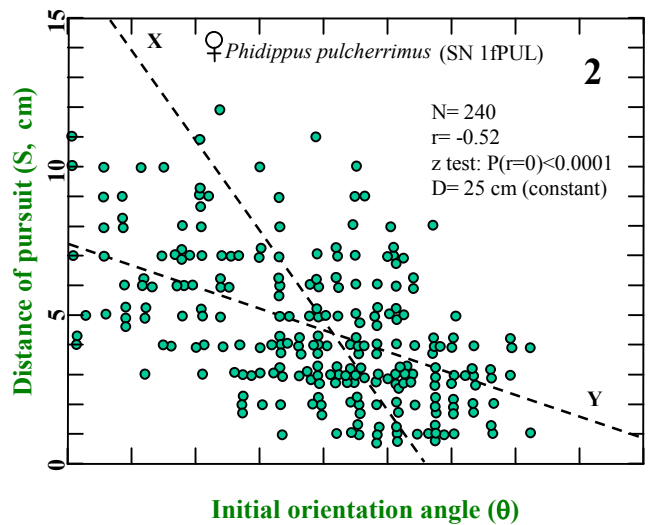
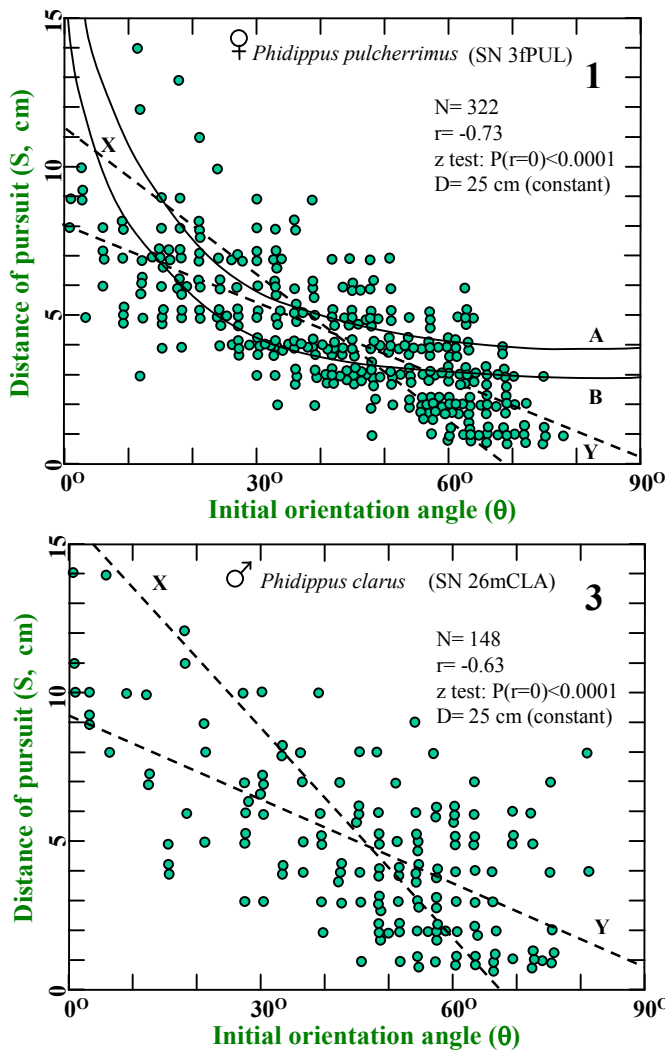

Figure 54. Distance of pursuit prior to reorientation (S) as a function of the initial orientation angle (θ), for runs on the horizontal bar. Results are shown for two different *P. pulcherrimus* (1, 2) and one *P. clarus* (3). Spiders exhibited a highly significant tendency to run a greater distance prior to reorientation when the target appeared at a smaller angle (θ) relative to the direction of the bar. Linear regressions of S on θ (labeled Y) and θ on S (X) are shown as dashed lines. In example (1) curves A and B were based on the equation $S=H(\cos\theta-\sin\theta/\tan\theta_c)$, where $\theta_c=(\theta+11^\circ)$ and H (theoretical distance estimate by the spider at the initial orientation) was equal to either 20 cm (curve A) or 15 cm (curve B). If the position at which the spider stopped was determined by a fixed change in the respective direction of the prey (in this example, by 11°), curves such as (A) or (B) might be expected to approximate this curve, depending on the specific distance estimate used by the spider. It is clear that θ was a significant determinant of S, but there was also significant variation in S (as much as 75%, or $1-r^2$) that could not be accounted for in this manner.

As shown in Figure 54, the initial orientation angle (θ) was also a significant determinant of the distance of pursuit (S) prior to reorientation.

With reference to definitions of θ_c , S, and L provided in Figure 43D:

$$\frac{d\theta_c}{dS} = \frac{\sin^2\theta_c}{L}$$

Since $\sin^2\theta_c$ increases (to 1.0) as θ_c approaches 90° , the rate of change of the angle between the route and the prey direction, per unit of distance moved, also increases as θ_c approaches 90° , given a fixed value of L (distance between the prey and the route). The hypothesis that a fixed value of $(\theta_c-\theta)$ (or $\Delta\theta_c$) drives the distance of the pursuit is presented in Figure 54. A rationale for this observed tendency can be developed as follows: When θ_c is small, an accurate reorientation is possible after a longer run (S), since θ_c is changing so slowly with respect to S. For a given prey distance (D), a longer run is also required to bring the spider to the closest possible approach on a particular linear route, when the initial angle θ is small.

When θ is larger, less movement along the route is required to bring the spider to the closest position relative to the prey. Finally, when $\theta = 90^\circ$, the spider is already at the closest possible approach.

The determination of an accurate reorientation angle (θ_c) requires much more than a memory of θ . Again with reference to the definitions provided in Figure 43D:

$$[1] \quad \theta_c = \arctan\left(\frac{\sin\theta}{\cos\theta - \left(\frac{S}{D}\right)}\right)$$

Thus, to calculate an accurate reorientation direction in a horizontal plane (angle θ_c), the spider requires accurate measurements for the initial target direction (angle θ), the distance of the pursuit (S), and the initial distance of the target (D). The spider's internal representation of prey or target location must be able to process this information.

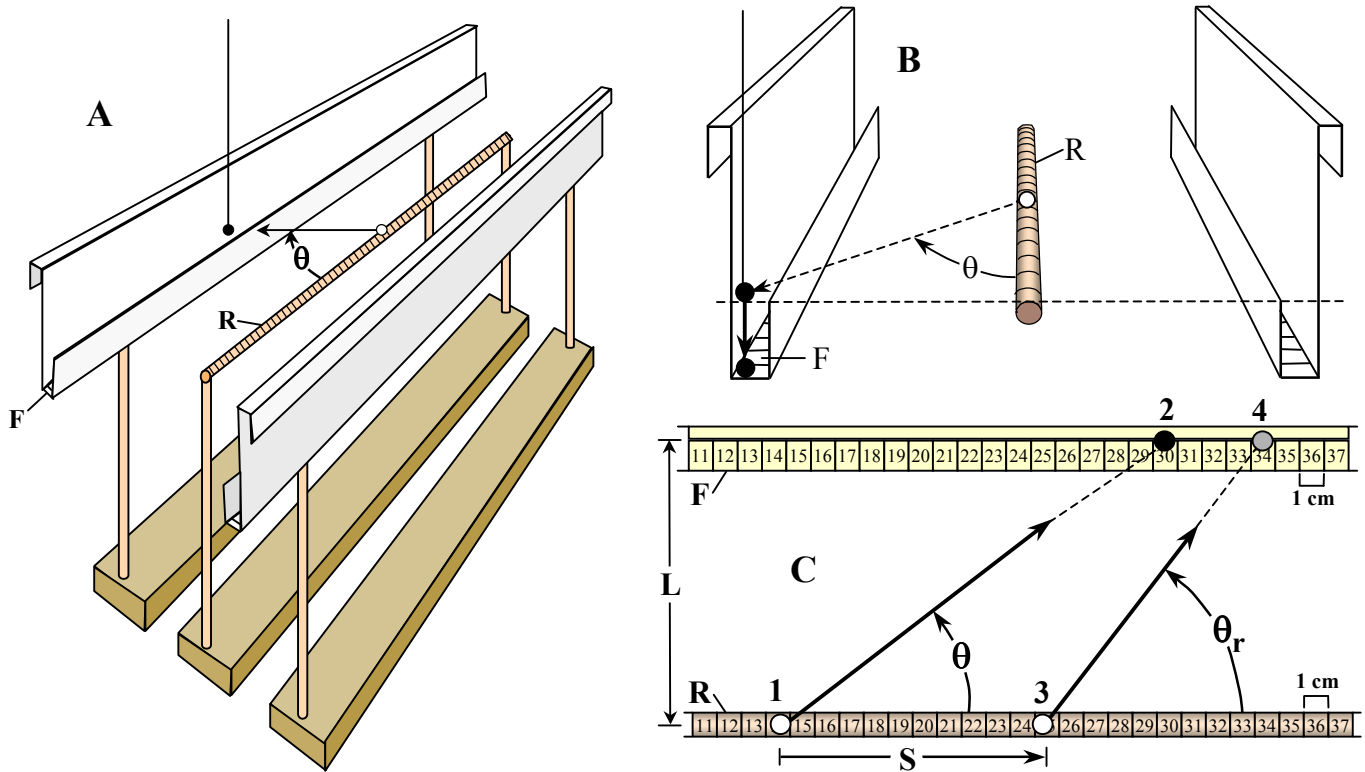
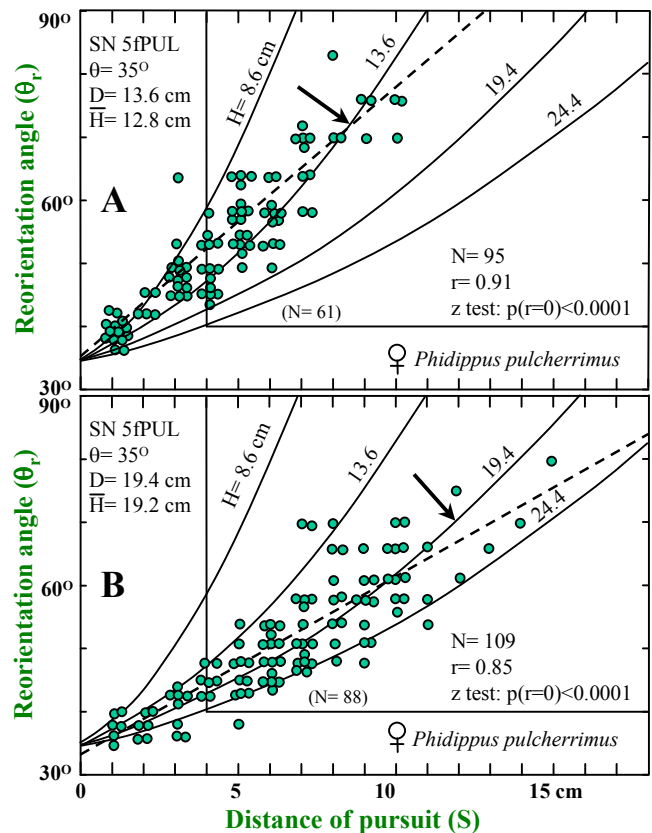

Figure 55. Three views of horizontal bar in corridor. A: Perspective drawing. Spider positions were read from the R scale on the bar. Target positions and reorientation directions were read on the F scale. The horizontal bar was 70 cm in length. Each of the walls or screens on either side of the corridor was constructed from a 100 cm long piece of heavy white paper. Trials were similar to those described in Figure 44, with the exception that the walls could be moved with this apparatus to vary the distance of the target. B: End-on perspective view of the bar, showing relative positions of the walls to the left and right. This shows how the standard lure (fly) dropped down into the trough (F), to move it out of view of the spider, at the onset of each pursuit. C: This shows how relative positions and directions were read off of the respective scales to support computation of S, θ , and θ_r . Except for the fact that the F scale was parallel to the R scale, all other conventions used here agree with those described in Figure 44.

To further study the relationship of pursuit distance (S) to the direction of reorientation (angle θ_r), the apparatus described in Figure 55 was designed, to support repetitive presentation of targets at a constant angle (θ) and distance (D). Results for five different spiders (*P. clarus*, *P. pulcherrimus*, and *P. regius*) are shown in Figures 56-60. These trials demonstrated a very strong correlation between the pursuit distance (S) and the observed reorientation angle (θ_r), supporting the hypothesis that these spiders compensate for their own movement when they reorient to face the expected position of the target. In addition, they demonstrated a close relationship between the actual target distance (D) and the spider's own estimate of target distance implicit in the observed movement (H).

Figure 56. Behavior of a female *P. pulcherrimus* on the horizontal bar in response to a constant θ (35°), for prey distance (D) = 13.6 cm (A), and for prey distance (D) = 19.4 cm (B). On each chart, four reference curves are shown, as defined by the function $\theta_r = \arctan(\sin \theta / (\cos \theta - (S/H)))$, based upon values of H (see definition in Figure 43) in cm that are given beside each of the curves. These curves represent the calculated reorientation angle (θ_c) as a function of the distance of pursuit, for each of the respective prey distances (D). In each chart, an arrow demarcates the reference curve corresponding to the actual prey distance (D) for the set of trials. Inset rectangles in each chart set off the subset of values where the conditions $S \geq 4.0$ cm and $\theta_r \geq 40^\circ$ were met. These values, considered to be of greater accuracy because of the greater distance of the runs, were used in the measurement of H.



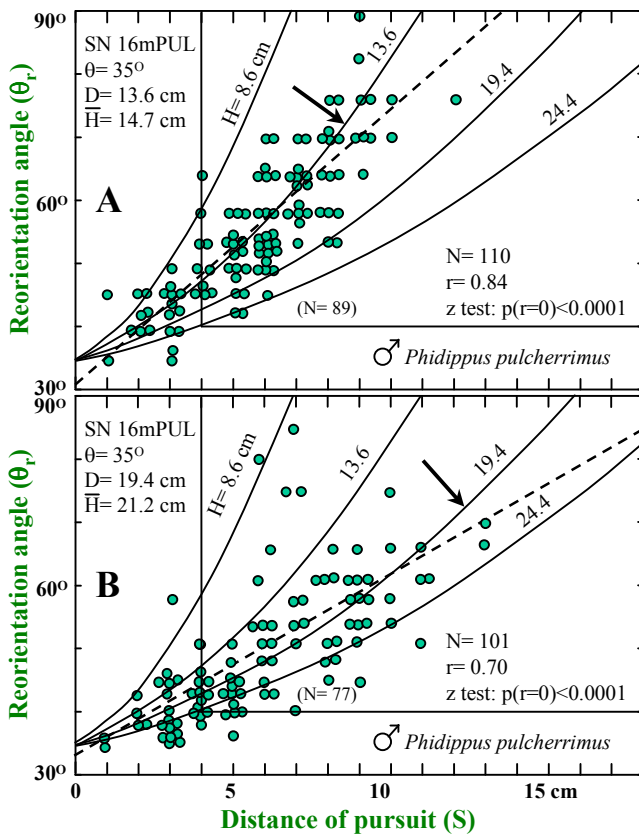

Figure 57. Behavior of a male *P. pulcherrimus* on the horizontal bar in response to a constant θ (35°) for $D = 13.6$ cm (A) and $D = 19.4$ cm (B).

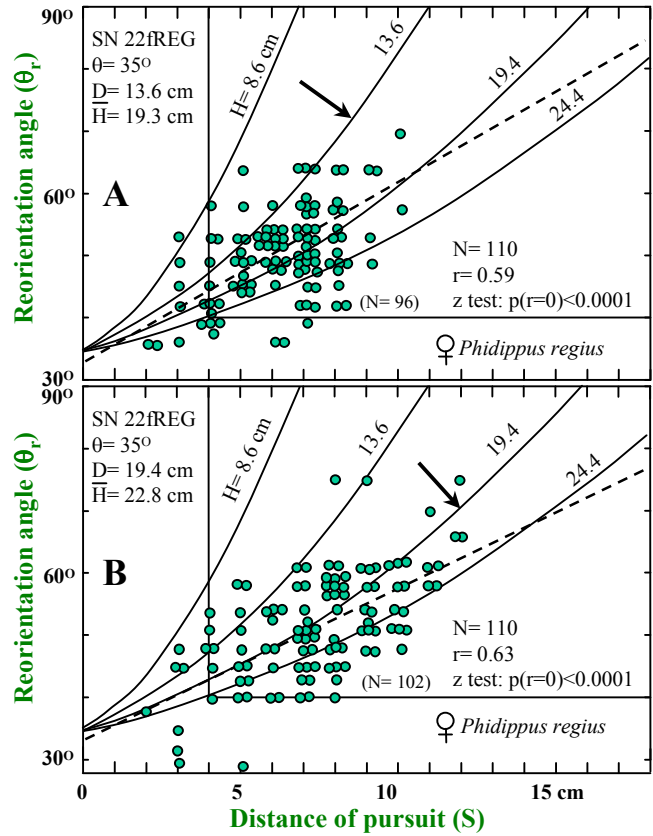

Figure 59. Behavior of a female *P. regius* on the horizontal bar in response to a constant θ (35°) for $D = 13.6$ cm (A) and $D = 19.4$ cm (B).

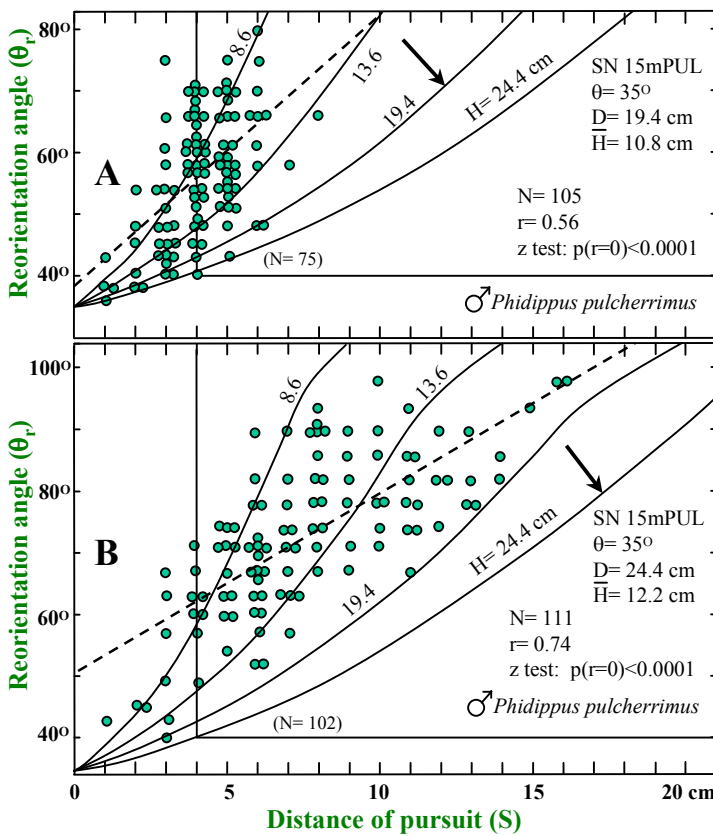

Figure 58. Behavior of a male *P. pulcherrimus* on the horizontal bar in response to a constant θ (35°) for $D = 19.4$ cm (A) and $D = 24.4$ cm (B). Although correlation of S and θ_r was highly significant, H values for this spider were underestimated.

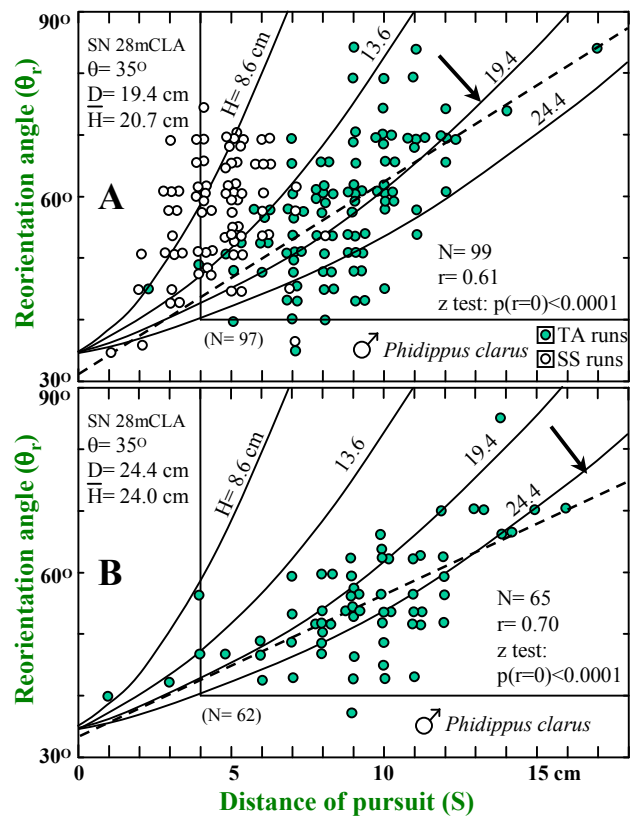

Figure 60. Behavior of a male *P. clarus* on the horizontal bar in response to a constant θ (35°) for $D = 19.4$ cm (A) and $D = 24.4$ cm (B). At the shorter distance, many of the runs of this spider involved side-stepping (SS) instead of the normally observed turn away (TA) runs. In (A) only the TA runs were used to calculate the correlation of S and θ_r .

A male *P. clarus* behaved differently from the other spiders during these trials (Figure 60). At target distance (D) = 24.4 cm, this spider turned away from the target to face the direction of its movement on the route (TA or turn away run, as depicted in Figure 43). At shorter distances, however, many of the runs by this spider involved side stepping (SS in Figure 60, D= 19.4 cm), whereby the spider would move sideways along the bar while maintaining an orientation in the direction of the target position. At a target distance (D) =14.6 cm, virtually all of the runs of this spider involved side stepping. At D= 19.4 cm, the average calculated H (implicit estimate of prey distance by the spider) was a close 20.7 cm (N= 99) for the TA runs. For the SS runs, the average calculated H was only 10.7 cm (N =76, $r=0.32$, $P(r=0)<0.005$).

A comparison of D with resultant H values for these trials is also presented in Figures 61-63.

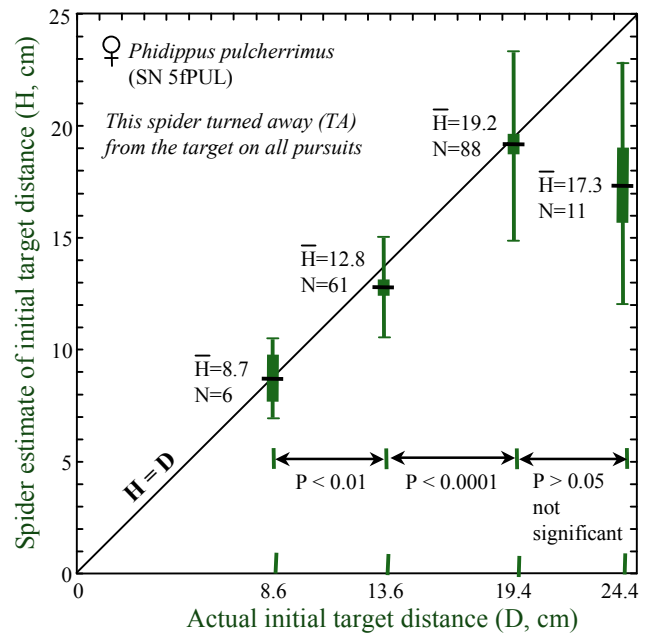

Figure 61. Comparison of H and D values for pursuits by a female *P. pulcherrimus* on the horizontal bar at a constant θ . Some of these data are also shown in Figure 56. The mean value of H is given for each value of D. Thick vertical bars correspond to ± 1 standard error of the mean H, and the vertical lines indicate ± 1 standard deviation for the range of calculated H values. P values, below, indicate the level of significance for the difference between respective mean H values at different distances. For this spider, 47 of 53 pursuits at D= 8.6 cm involved side stepping (SS) instead of turn away (TA) pursuit, and only the TA results are reported here. Note also the constraints on selection of data for these comparisons that are described in Figure 56. At least up to a range of about 15-20 cm, it appears that this spider used a fairly accurate estimate of D.

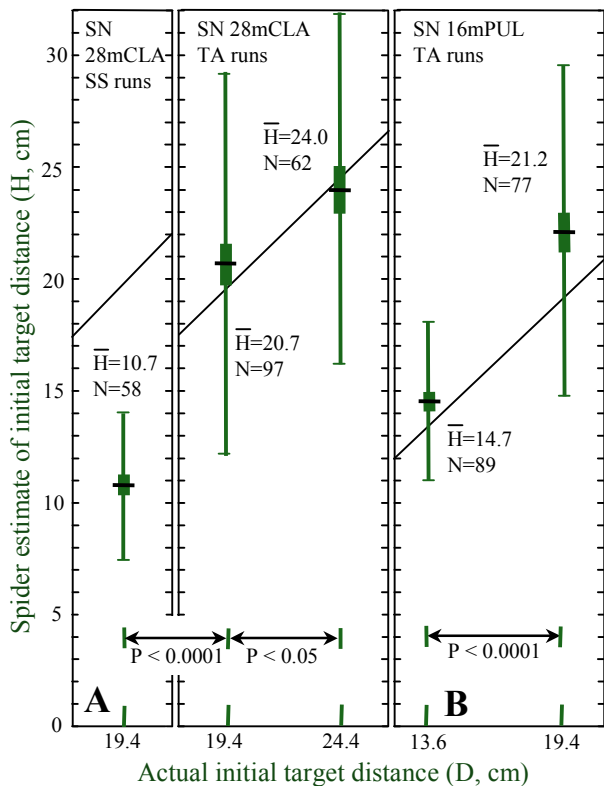

Figure 62. Comparison of H to D for pursuits on the horizontal bar by two different spiders. A: This shows the significant underestimate of prey distance associated with the side stepping (SS) pursuits described in Figure 60A, as compared to TA runs associated with the same value of D. B: The response to the difference in target distance (D) for this individual was highly significant. These trials are also described in Figure 57.

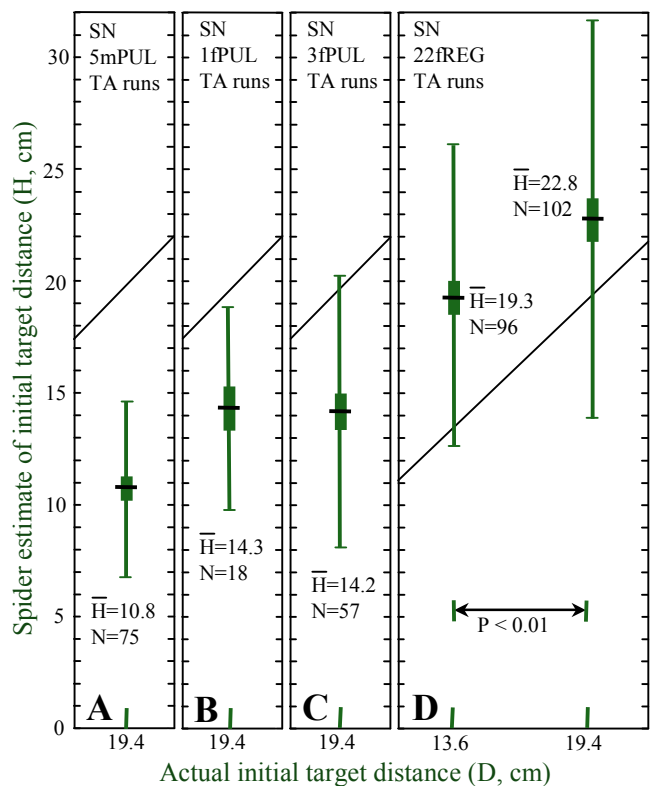

Figure 63. Comparison of H to D to pursuits on the horizontal bar by four spiders. A-C: The three *P. pulcherrimus* shown here consistently underestimated target distance with D= 19.4 cm. Trials for one of these spiders are also described in Figure 58. D: The difference in H was significant for the two values of D, for this *P. regius*. These trials are also described in Figure 59.

General discussion of route-referent (θ) orientation

As shown earlier, and as defined in Figure 43,

$$[1] \quad \theta_c = \arctan \left(\frac{\sin \theta}{\cos \theta - \left(\frac{S}{D}\right)} \right)$$

And also,

$$[2] \quad \theta_r = \arctan \left(\frac{\sin \theta}{\cos \theta - \left(\frac{S}{H}\right)} \right)$$

Where,

θ is the angle between the bar and the initial target direction as seen by the spider

θ_c is the angle between the bar and the direction of the initial target location after displacement S during pursuit

θ_r is the measured angle between the bar and the the mid-sagittal plane of the spider's prosoma when the spider reoriented after pursuit

S is the displacement or distance moved by the spider during pursuit

D is the initial distance of the target from the spider

H is an estimate of the initial distance of the target from the spider that is implicit in the behavior of the spider, as calculated from equation [2]

The major experimental findings presented in this section can be summarized as follows:

- (1) The observed θ_r correlated closely with, and tended to agree with, the calculated θ_c , across a range of variable target directions relative to the route (θ).
- (2) For constant values of D and θ , the direction of the reorientation turn (θ_r) correlated closely with the pursuit distance of the spider (S).
- (3) Within a certain range that varied by individual spider, there was a good correlation between D and the estimate of original target distance implicit in the pursuit, H .
- (4) For a constant value of (D), the pursuit distance (S) prior to reorientation increased significantly when the target was closer to the route (when θ is smaller)
- (5) Spiders running these pursuits did not appear to utilize any visual cues outside of the apparatus to determine direction, and pursuits with accurate reorientation turns were made in complete darkness.
- (6) The force of gravity was sufficient to allow these spiders to define a horizontal plane of reference.

These results support the general hypothesis that these spiders case use internal memory or representations of D , θ , and S to compute an accurate direction of reorientation from a new location (θ_c), as depicted in equation [1], provided that the force of gravity is also available to define a horizontal plane of reference.

Additional evidence for the ability of *Phidippus* to evaluate both θ and D can be found in the demonstration that these variables can determine the onset of pursuit (Figure 64).

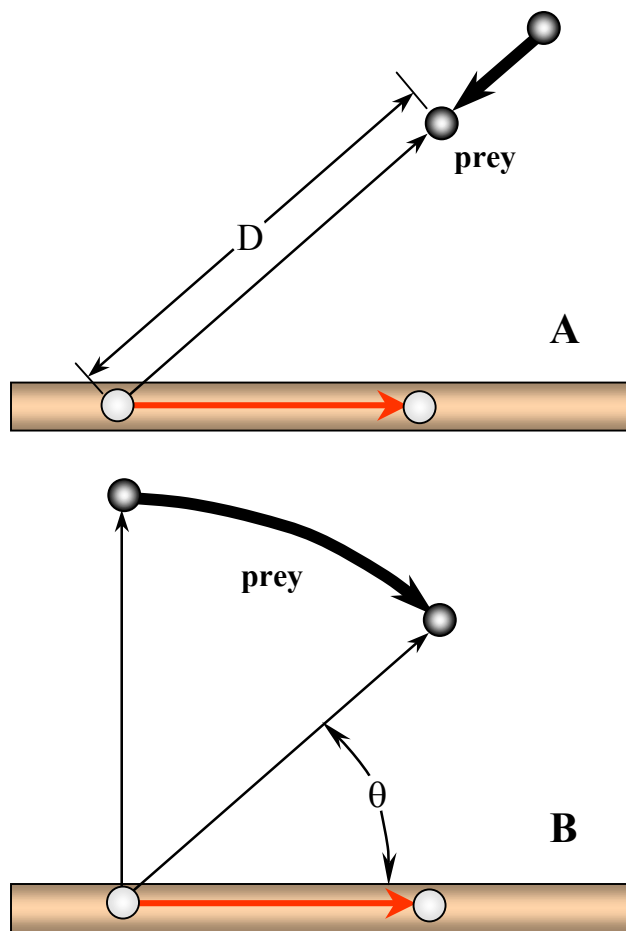

Figure 64. Both prey distance (A) and prey direction relative to the route of pursuit (B) can elicit pursuit by *Phidippus* jumping spiders. A: As prey was moved toward a waiting spider (open circle) a critical distance (D) was attained at which the spider would turn to run along the bar in pursuit. B: As the prey was moved along an arc at a constant distance from the spider, the angle between the prey and the route of pursuit (θ) was reduced, until a critical value was attained at which the spider would turn to run a pursuit.

Although values of θ ranging from 0° to 90° (acute angles) were used in these horizontal bar experiments, qualitative observation of many other problems of pursuit shows that there is no limitation on the direction of the immediate route of pursuit with respect to the prey direction. A very simple demonstration of this fact, that has been repeated many times, is depicted in Figure 65. In one variant of this demonstration, it can be shown that some spiders will not move from their initial position to begin a pursuit unless the connection (faced at 2) is visible.

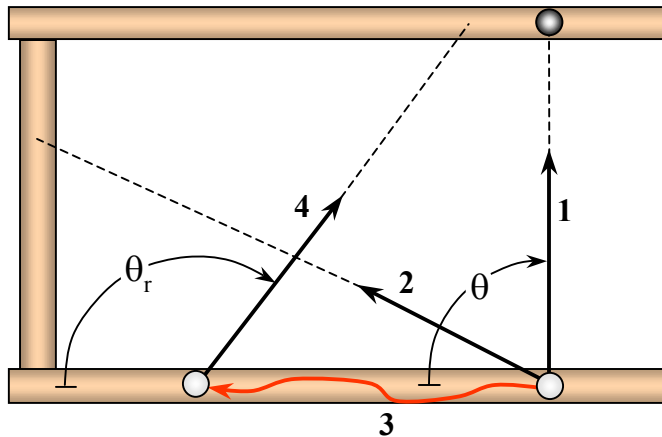

Figure 65. Simple demonstration that the reorientation angle in a horizontal plane of pursuit can be obtuse (can exceed 90°). Here the spider oriented to the prey (1), turned to face a visible connection or secondary objective (2), ran toward the secondary objective in pursuit (3), then completed an accurate, obtuse reorientation turn (θ_r , 4).

The ability of *Phidippus* to accurately estimate distance, and to use the force of gravity as a reference, have also been demonstrated in the context of their targeted jumps (Hill, 2006a). The measurements of H reported here should be taken as an indicator of limitations related to the ability of these spiders to measure distance, as it also incorporates all of the error in their ability to resolve direction and the extent of their own movement.

The ability to maintain a functional memory of distance traveled has been demonstrated for many other invertebrates, including insects (*Apis mellifera*, Frisch and Jander 1957, *Cataglyphis bicolor*, Burkhalter 1972, Duelli 1976) and spiders (*Agelena labyrinthica*, Dornfeldt 1975b, *Cupiennius salei*, Barth 1976).

In spiders, it is possible that the amount of dragline silk played out during a pursuit could be used as a gauge of distance traveled. A running count of steps or leg movement could also be used.

Some *Phidippus* frequently side-stepped (walked sideways, continuously facing the target direction) when targets were located at shorter distances from the bar (Figure 60A). Except where otherwise noted, only the trials where these spiders turned away from the target at the onset were used in these experiments. Even when they turned away, spiders varied considerably with respect to the details of their approach to prey on the bar (Figure 66). These observations (and Figure 66A in particular) support the hypothesis that these spiders actively used the concept (or *internal representation*) of *direction relative to a route in a horizontal plane*, even if this was supplemented by an internal memory of the respective stepping pattern to determine the reorientation direction. Some spiders consistently chose a slower, more concealed approach (Figure 66D, Figure 43A).

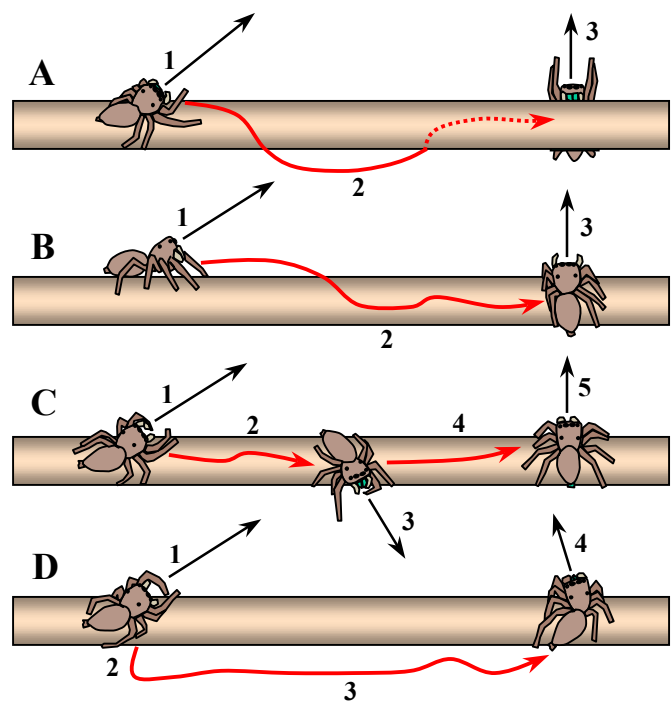

Figure 66. *Phidippus* spiders were not locked into a simple *advance and reverse facing turn* pattern as they pursued a target on the horizontal bar. Some common variants are shown here. A: After initially sighting prey to the left from the top of the bar (1), the spider ran (2) and reoriented in the appropriate direction by turning very quickly to *its right* when beneath the bar. B: An initial β turn (see Figure 10) to face the target was followed by pursuit on top of the bar (2) and then by an α turn (see Figure 9) to face the expected target location. C: After the initial orientation (1), this spider was distracted during pursuit (2) and it turned to face the distraction on the opposite side of the bar (3). It then turned and continued the initial pursuit (4), and reoriented successfully toward the initial target position (5). D: Some individual spiders (including SN 5fPUL, 16mPUL, and 28mCLA) routinely side-stepped to the opposite side of the bar (2) and then completed a very steady, apparently paced walk (3) on the opposite side of the bar from the initial target direction, followed by, in general, a remarkably accurate reorientation turn (4). This behavior is also shown in figure 43A. These were the spiders with the most accurate H (implicit distance estimate) values, and they generally faced the target for a longer period of time (position 1) prior to pursuit, when compared with other spiders. Each of the behaviors shown here (A-D) has been observed many times.

A general ability to compensate for a forced turn in one direction with an appropriate turn in the opposite direction (*reverse turn*) has been demonstrated in many arthropods (Akre 1964, Wilson and Hoy 1968, Burger 1971, Schafer 1975a, Schafer 1975b). *Phidippus* jumping spiders have been observed to maintain a fairly straight course on a horizontal surface, in near darkness, weaving alternately to the right and left as they move. Since there are no allothetic or external cues available to support this kind of movement, we can safely assume that these spiders also have a significant internal (idiothetic) *sense of direction* or *path integration* capability that compensates for their own movement. Body movements may be recorded internally through proprioception, tracking of motor commands or higher level commands, or some integrated combination of the two. Yet qualitative observations reported here (Figure 66) also suggest that allothetic cues related to the direction of the immediate route are very important to these spiders, when these cues are only available through contact.

Every reorientation turn that was measured on the horizontal bar was directed toward the same side (either to the right or to the left) as the initial orientation turn. This included every turn that was executed in complete darkness (Figure 52), as well as those in which the spider reoriented from the underside of the bar (Figure 66A). There may be individual spiders that confuse their right and their left, with respect to a horizontal plane, but they were not observed here.

Earlier (Figure 52) it was shown that vision was not required as a reference direction for the *reorientation turns* observed on the horizontal bar, but this observation does not preclude its use as a supplemental source of information, when these cues are available and they do not conflict with other information. During the initial orientation to face the target, these spiders used their vision to identify this as prey, and to measure its distance. During this initial orientation and prior to pursuit, spiders may have also used their vision to measure the direction of the target relative to the visible route of pursuit. This interpretation is consistent with observations reported in Figure 64B.

It is a challenge to isolate the various cues (internal record of body movement, visual information, tactile information, gravity information) that may be used in the course of *route-referent* orientation. The working hypothesis here is that all of these are important, and that all forms of available information can contribute to the internal representation of location (position and direction) that is used by these spiders, as well as the internal representation of the route or *path of movement*.

10. Use of gravity to determine direction (*gravity-referent orientation*)

The term *salticid*, and the common name *jumping spider* immediately suggest the importance of gravity in the lives of these spiders. I recently (Hill 2006a) demonstrated how these spiders orient with respect to gravity to gain the range required to hit their targeted prey as well as target positions that they are moving to (see also Figures 67-68). Substantial evidence in support of the hypothesis that these spiders use the force of gravity as a directional reference (*to define a horizontal reference plane*) was already presented and discussed in the previous section. For pursuits on the horizontal bar, gravity could not be used to determine direction *within* the horizontal plane of pursuit, but it was used to define the horizontal plane.

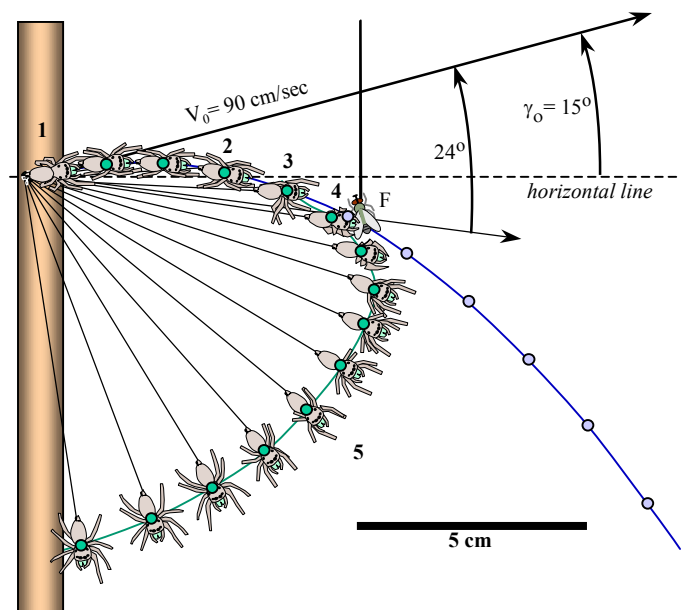

Figure 67. Predatory jump of an adult female *P. pulcherrimus*. Sequential positions of this spider at 15 msec intervals are based on a photograph of the jump obtained with the use of an electronic strobe light as described by Parry and Brown (1959). The spider jumped from a position on a vertical wood bar (1) in response to presentation of the standard lure (F). After essentially ballistic flight (2), the spider began to brake on the dragline and the spine-bearing legs continued to move forward (3) into a catching basket near the position of the sighted prey (4). Missing the target, the spider locked its dragline and swung back toward the bar as a pendulum (5). The application of a dragline brake is routine in this kind of jump. The trajectory that would have been followed by this spider if it had not braked is shown to the right (blue line), based on an initial velocity of about 90 cm/sec directed 24° above the observed prey position. Execution of successful jumps at this range and orientation requires that these spiders jump above the prey position in order to fall down upon it. To complete accurate ballistic attacks, *Phidippus* can adjust both their direction relative to gravity (γ_0) and the magnitude of their take-off velocity (V_0) (Hill 2006a).

In this section we will review a series of experiments designed to evaluate the use of gravity by these spiders to determine an appropriate direction of reorientation. In the subsequent section, we will review experiments that demonstrate the manner in which gravity affects the selection of a route of pursuit, or the pursuit response itself.

For a terrestrial organism, the force of gravity is an omnipresent fact of life. As a potential reference for orientation, the force of gravity is totally dependable. Plant configurations may be ambiguous or obscured from the view of a spider at times, and they may even move in the wind, but gravity is always readily available and reliable.

Araneid spiders (e.g., *Araneus*, Peters 1932, *Argiope*, Robinson 1969, and *Zygiella*, LeGuelte 1969) are known to use gravity-referent memory of web locations. The agelenid spider *Agelena labyrinthica* has been shown to use gravity cues, in preference to light cues, to determine the direction of return to its retreat (Bartels 1929, Holzapfel 1933). The specific mechanism by which spiders collect information with respect to the force of gravity is not known at this time. Wigglesworth (1972) suggested that the *sense of gravity* may be related to the sense of position and contact distributed over the body of an insect, or at least the weight of organs or limbs with respect to the rest of the body.

Many more general observations support the hypothesis that these spiders orient with respect to gravity. Most *Phidippus* that were observed consistently ran along the top of a horizontal bar. The tendency of these spiders to move to the upper side of an inclined bar, even if it deviated by less than 10° from the vertical, was frequently observed. It is possible that the upper surface of a horizontal route supports more rapid movement, in the sense that spiders did not need to grasp the surface so tightly to prevent falling.

The apparatus described in Figure 68 was used to study movement and reorientation in a vertical plane, in the same manner that the apparatus described in Figure 44 was used to study movement in a horizontal plane. Methods and conventions of measurement that were defined in Figure 43 also applied. As a convention, directions with respect to gravity are specified by their inclination with respect to a horizontal plane (γ). Directions above the horizontal plane were assigned positive γ values, and those below the horizontal plane are assigned negative γ values.

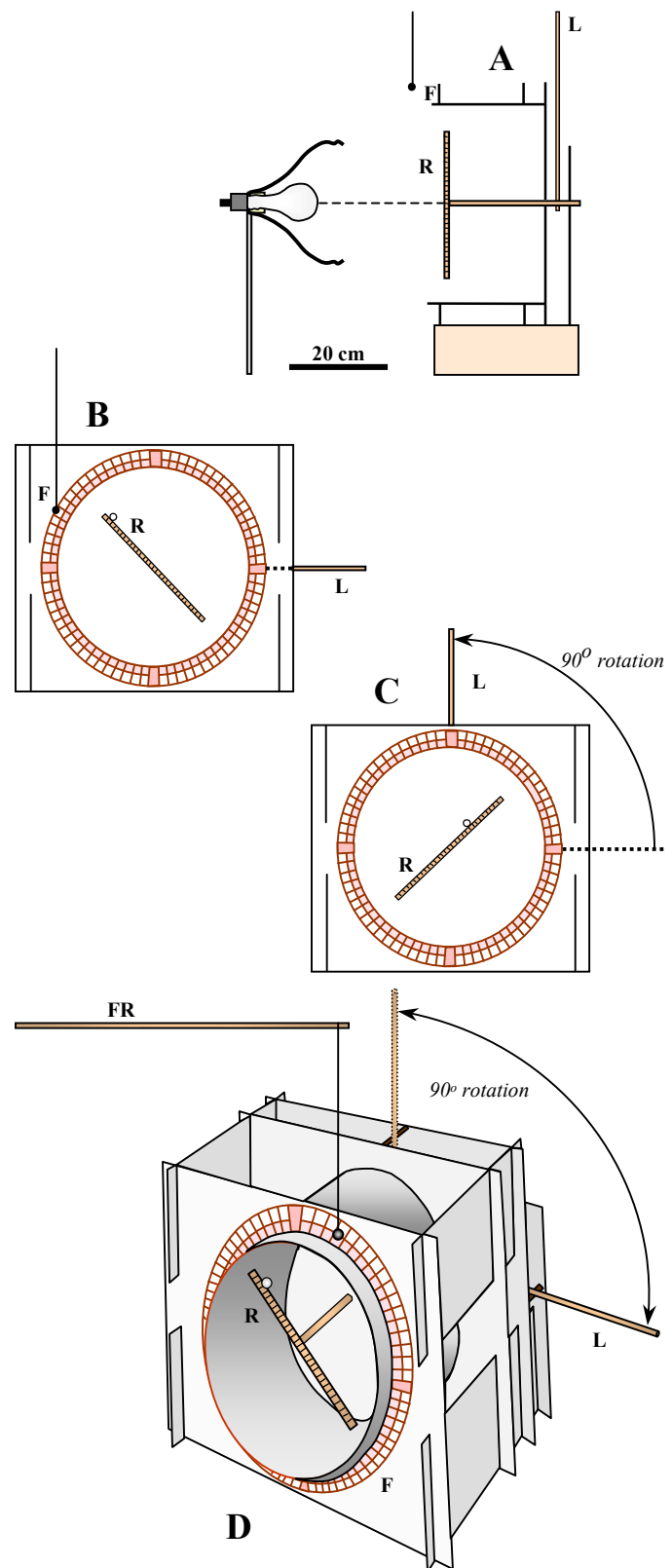

Figure 68. Apparatus use to study pursuit behavior in a vertical plane. The apparatus is shown in vertical section, from the side (A), in frontal view (B and C), and in perspective (D). During movement of the spider on the rod (R), the bar could be rotated 90° as shown, in either direction (clockwise or counter-clockwise, as viewed from the front). As shown in (A), the lamp was centered on the access of this apparatus, otherwise the room was dark. The circumferential scale (F) was divided into 5° units, and the running scale (R) was divided into 1 cm units. As in previous experiments, the lure (suspended from a small rod, FR, in D) was moved inside of the inner cylinder to conceal it from the spider during each pursuit and subsequent reorientation. This structure was built with clean, heavy white paper (poster board), with wooden dowels and supports in the base. The running bar (hardwood dowel) was 30 cm in length and 9 mm in diameter.

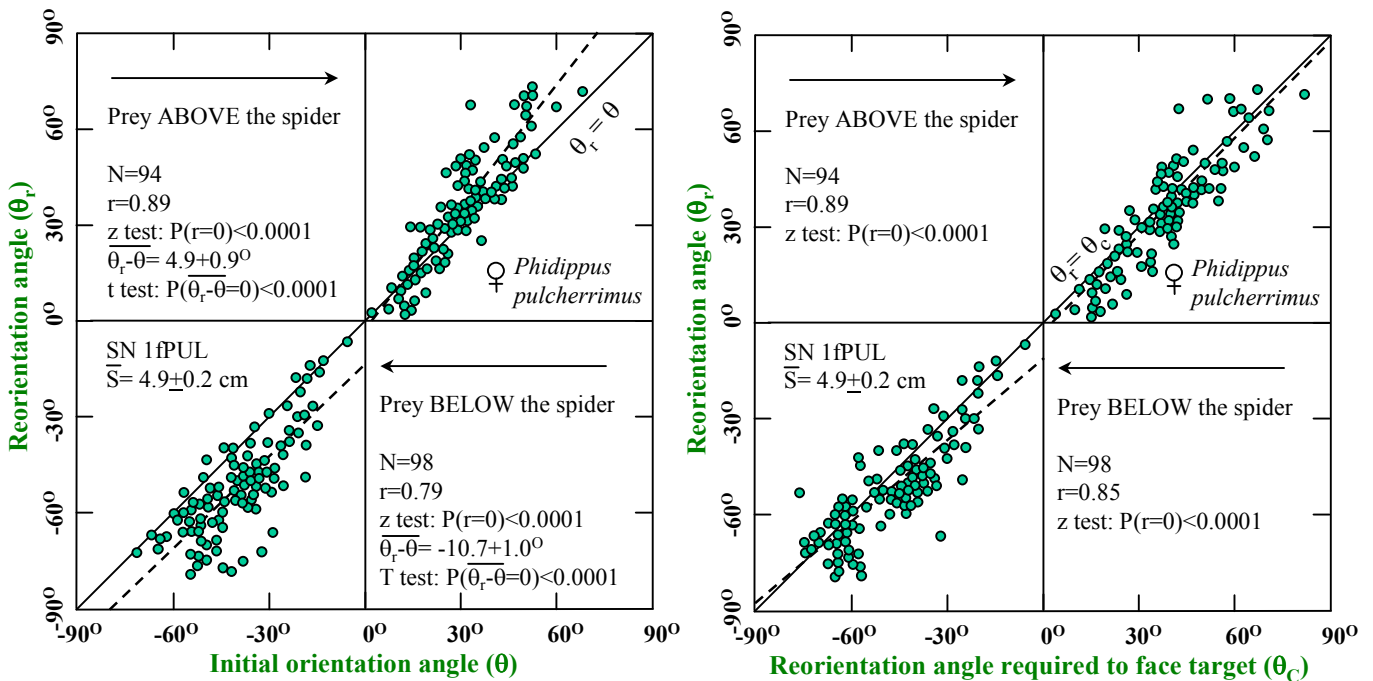

Figure 69. Reorientation in a vertical plane by a female *P. pulcherrimus* on a horizontal bar, within a vertical plane as described in Figure 68. As a convention, values of θ which specify a direction above the horizontal bar are positive, and those which specify a direction below the bar are negative. In all respects these results, including the accuracy of the observed reorientation turns (θ_r as an estimate of θ_c), compared with pursuits in a horizontal plane.

Initial trials involved runs on a stationary *horizontal* bar, based on orientation in a vertical plane (Figure 69). Spiders demonstrated the ability to reorient accurately toward the original position of the target in these trials, whether that target was situated above or below the bar. Although the results were comparable to those observed in the horizontal plane, reference systems available for reorientation by the spider were quite different in these trials. Spiders consistently reoriented within the correct vertical plane, even though gravity alone could not be used to identify this plane (since all possible vertical planes would have the same orientation with respect to gravity). Two sources of this information were available. One was the visual image of the edge of the cylinder, and the other was the orientation of the route *within a horizontal plane* (the latter specifying a vertical plane that contained the route and was perpendicular to the horizontal plane). Both sources of information were available to specify the vertical plane, and both may have been used concurrently.

To determine target direction within the vertical plane, there were two concurrent sources of information available. One was the direction of the target with respect to gravity (inclination with respect to a horizontal plane, γ). The other was the route or direction of movement (route-referent orientation). It was not possible to distinguish between these two sources of directional information with this experimental configuration.

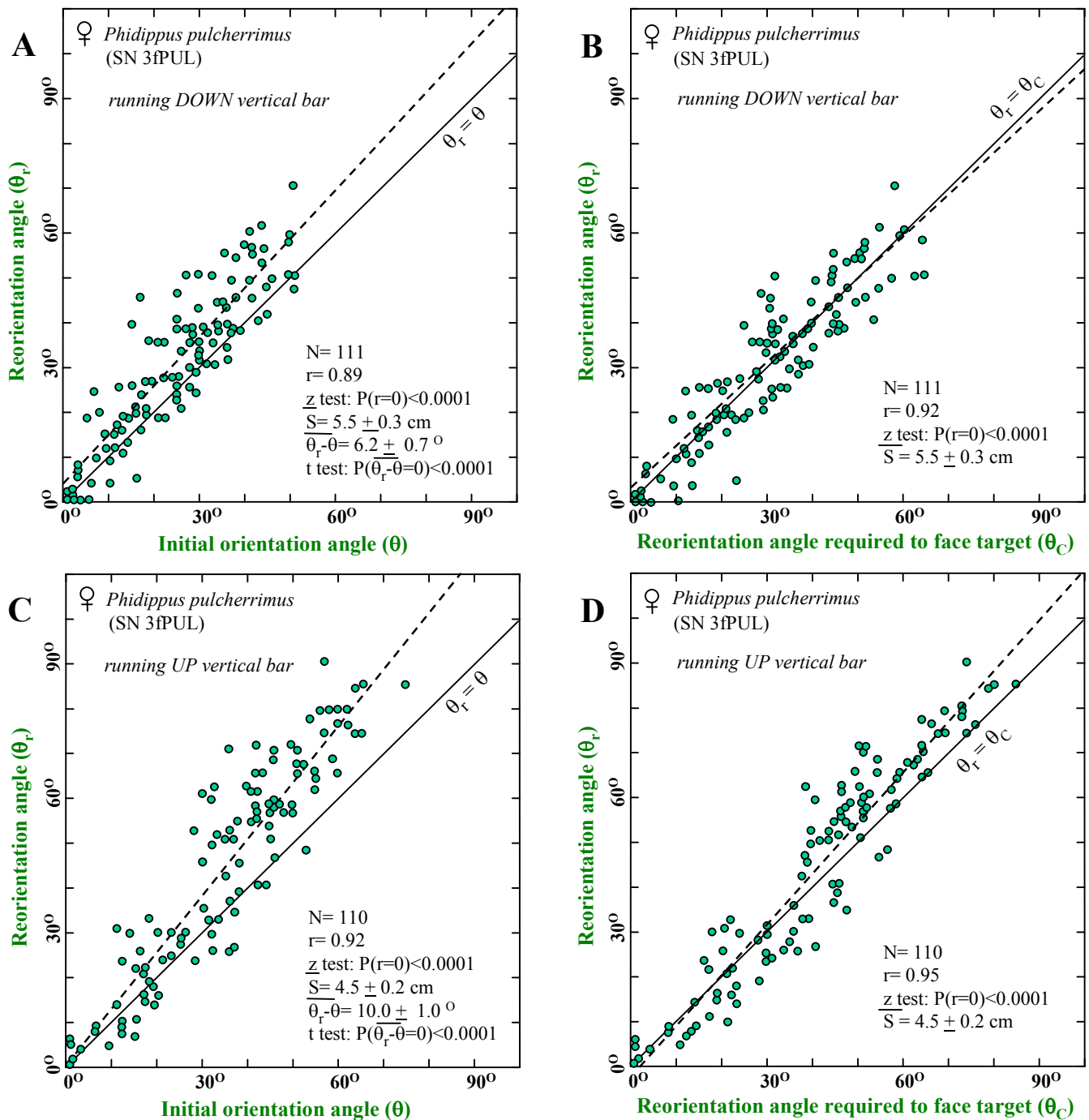

Figure 70. Reorientation behavior of a female *P. pulcherrimus* running down (A and B) and up (C and D) a vertical bar in pursuit. In all cases results were comparable to those observed for the horizontal bar, with a very high correlation and agreement between θ_r and θ_c .

A second series of trials involved runs on a stationary vertical bar (Figures 70-71). Results were very similar to horizontal bar results, whether the spiders ran up or down during pursuit. Correlations between θ_c and θ_r were also remarkably high, even for relatively long pursuit runs.

Unlike the situation with a horizontal bar in a vertical plane of pursuit, this vertical bar problem required the use of visual cues (most likely the association of the prey position with the edge of the inner cylinder of this apparatus) to determine a radial direction for the vertical reference plane.

The combination of vertical route and gravity alone could only specify a set of possible vertical planes, each containing the vertical route. External visual cues used to define a radial direction from a vertical route will be explored in more detail in a subsequent section.

As in the preceding experiment, both gravity and the route itself were available as reference directions within the vertical plane of pursuit, and this experiment was not capable of resolving the relationship between the two sources of information.

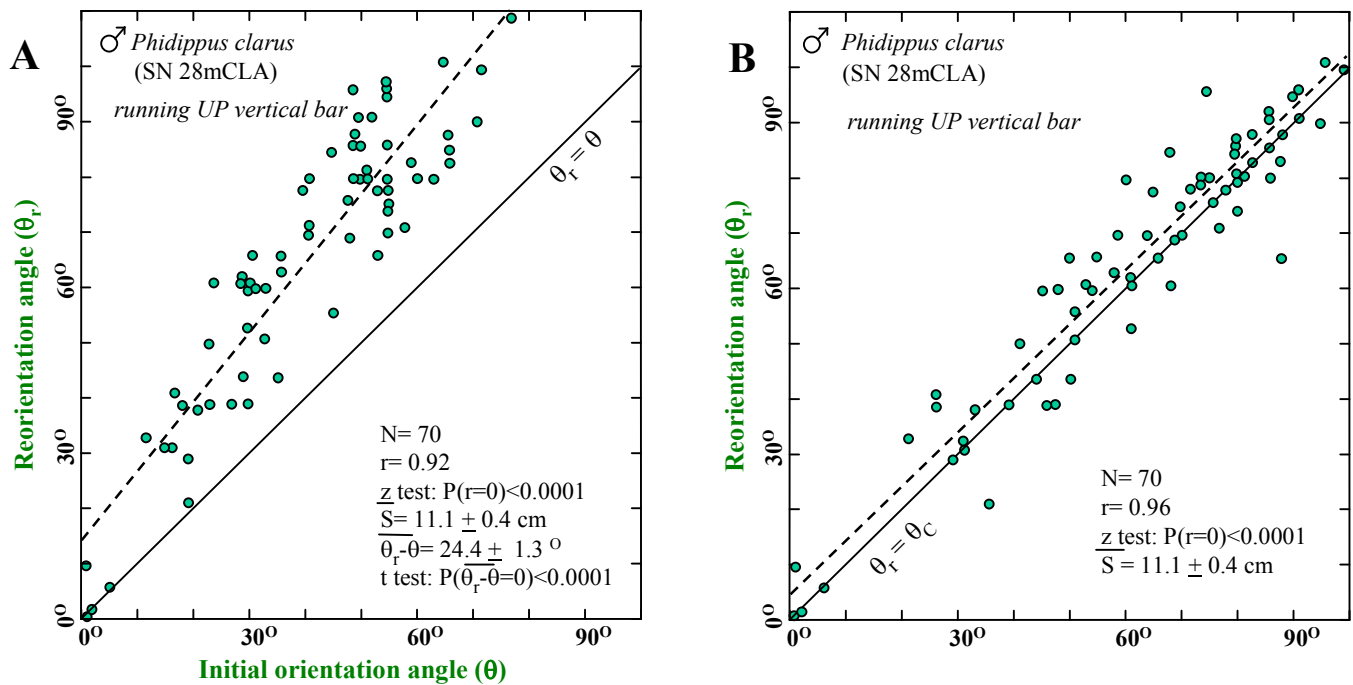

Figure 71. Reorientation turns executed in a vertical plane by a male *P. clarus* running up a vertical bar in pursuit. This individual ran very long (average 11.1 cm) and fast ascending pursuits, generally on the side of the bar opposite to the prey direction. The correlation between θ_r and θ_c was very high.

To explore the relationship of these two forms of directional information (route-referent or θ information, and gravity-referent or γ information), the lever on this apparatus (Figure 68) was used to rotate spiders by 90° during pursuit (explained in Figure 72). For these trials, pursuit began with the spider running down a bar inclined at a 45° angle in the vertical plane. During each run, and prior to reorientation, this bar was rotated by 90° , so that the spider was running up at a 45° angle at the time that it completed a reorientation turn. As shown in Figures 73-76, the result was that spiders oriented in the vertical plane with respect to gravity (gravity-referent orientation), 90° off of a direction that could be associated with route-referent orientation. In cases where the prey was originally sighted at $\theta = 0^\circ$, spiders actually reoriented in a direction 90° to the right of this, at a right angle to the route of pursuit.

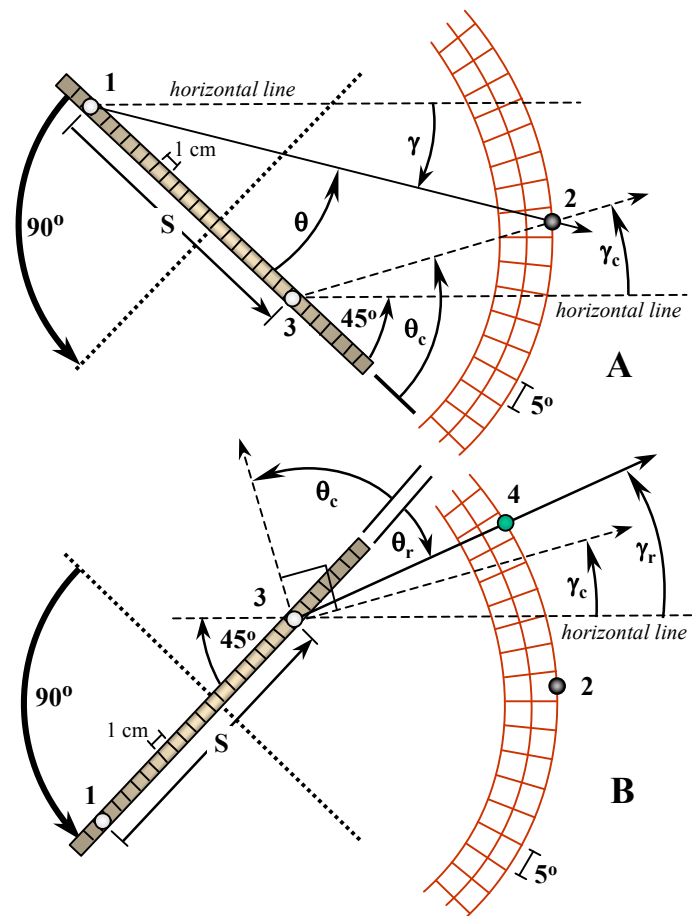

Figure 72. Running bar in vertical plane before (A) and after (B) a 90° rotation in the vertical plane during a pursuit of distance S . The apparatus used is described in Figure 68. As in experiments on the horizontal bar, values for positions 1 (the initial position of the spider), 2 (the position of the lure), 3 (the reorientation position of the spider), and 4 (the reorientation direction of the spider) were read from respective bar and circumferential scales. From these data, θ , θ_r , γ , γ_r , and γ_c were computed for each trial, as shown here. For these trials, agreement between θ_r and θ_c would indicate that reorientation in the vertical plane was primarily route-referent. Agreement between γ_r and γ_c would indicate that reorientation in the vertical plane was gravity-referent. The result, as shown in Figures 73-76, and also in this diagram, was that there was close agreement between γ_r and γ_c , and reorientation in the vertical plane for this experiment was gravity-referent.

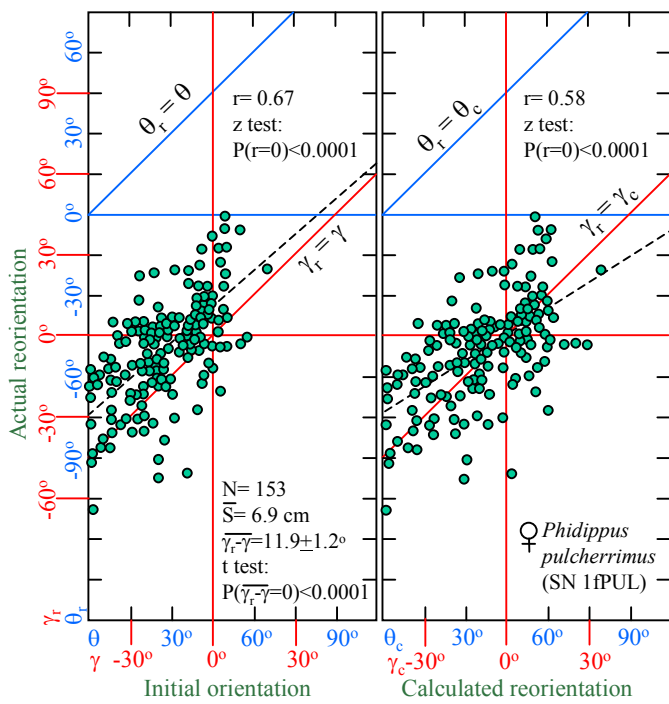

Figure 73. Results of the rotation experiment described in Figure 72 for a female *P. pulcherrimus*. In these composite graphs, two scales are given for each axis, one corresponding to θ and the other corresponding to γ measurements. The same data are shown in both charts. Note how observed values of θ_r deviated from θ_c by about 90° , whereas there was good agreement between γ_r and γ_c . This supported the hypothesis that gravity-referent orientation was used to determine the direction of reorientation in a vertical plane.

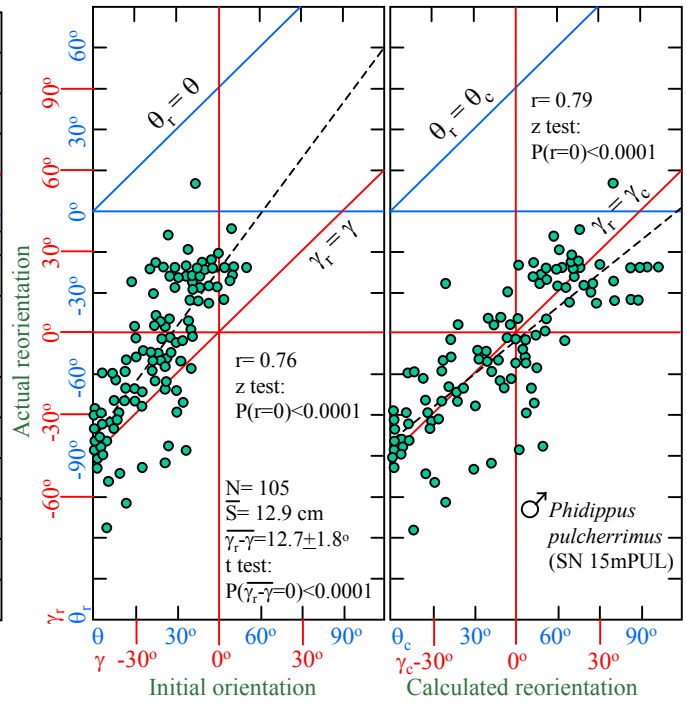

Figure 75. Results of the rotation experiment described in Figure 72 for a male *P. pulcherrimus*. This experiment worked very well with this individual because it tended to complete a long (average distance 12.9 cm) and fast run, allowing ample time to complete the smooth rotation of the bar prior to the reorientation turn. The resultant correlation of γ_r with γ_c was relatively high.

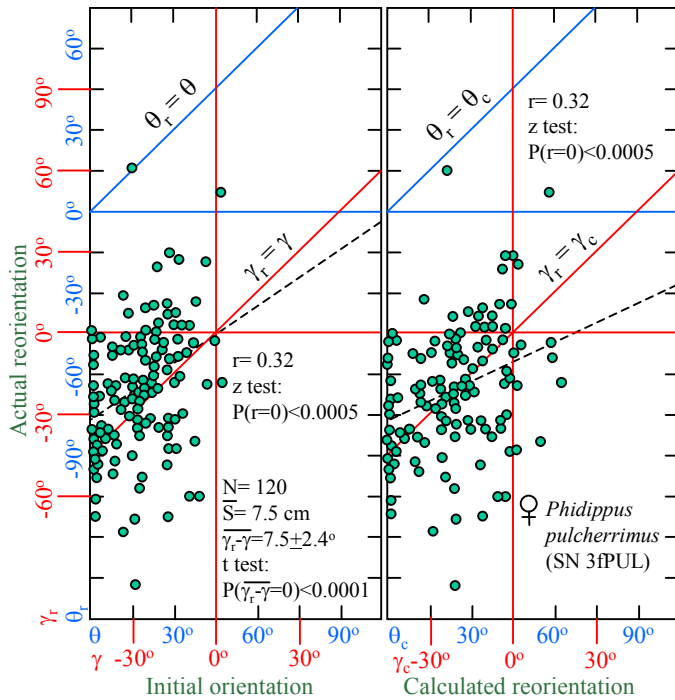

Figure 74. Results of the rotation experiment described in Figure 72 for a different female *P. pulcherrimus*.

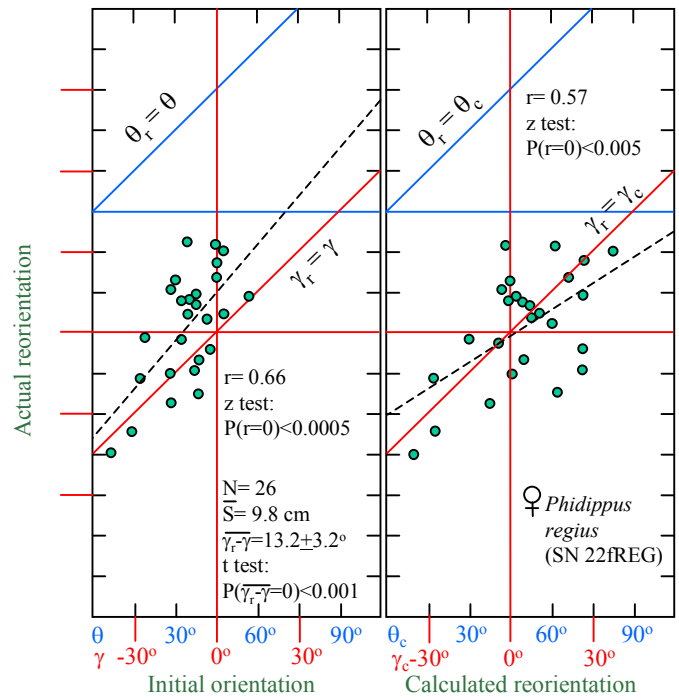

Figure 76. Results of the rotation experiment described in Figure 72 for a female *P. regius*.

This was a clear demonstration that these spiders would use gravity to the exclusion of cues provided by the immediate route of pursuit to determine the direction of reorientation in a vertical plane. This result is consistent with the hypothesis that these spiders *only* use the omnipresent force of gravity to determine a direction in a specified vertical plane. This would relegate the role of route-referent orientation to the *left or right decision* in a horizontal plane, where gravity is not available.

If you conducted this experiment in an inertial spacetime reference frame (per *General Relativity*, in a space capsule orbiting the earth where the spiders would not be subject to the acceleration of gravity as a cue), it is possible that these spiders would use the same route-referent orientation that they used with the horizontal bar, as there would be no distinction between horizontal and vertical. Between the demonstrated use of visual cues to establish radial direction when gravity is not available for this purpose, and the ability to use route-referent orientation on a horizontal bar, again where gravity is not available for this purpose, the spider is equipped with the two sources of information required to make successful reorientation turns, or to determine direction, in the absence of gravity.

The fact that these spiders reoriented *as if the rotation had not taken place* suggests that they used an initial determination of target distance (D) as well as the direction of the target with respect to gravity (γ , see Figure 72 for definitions), in combination with a representation of their own movement (S) to compute the direction of reorientation with respect to gravity (γ_c). The use of γ to make the initial measurement of direction (instead of θ) is again consistent with the hypothesis that these spiders normally use gravity to measure a direction in a vertical plane.

One piece of information required for a successful reorientation turn is missing in this analysis: the *direction* of the pursuit run. The hypothesis that only gravity is used to determine direction in a vertical plane suggests that this information was collected as γ_s (the direction of the route of pursuit with respect to gravity) *at the onset of the pursuit*, and that subsequent rotation of the spider and the route did not impact this initial reading. This interpretation is consistent with the observed results. On the other hand, the spider may have made an idiotic (internal) motor or sensory calculation at the onset to update its relative direction with θ information as it turned to the route. In any case, the spider had to make a reading that would allow it to determine the relative direction of the route with respect to gravity, in a vertical plane, at the onset of pursuit (most likely as it turned to face the route), and it had to use this information *to the exclusion of any subsequent readings as the route was moved*, to obtain the observed results.

Either a direct reading of γ_s was required at the onset, or the spider had to combine a reading of γ (target direction with respect to gravity) with the route-referent reading of θ , in order to compute γ_s . Since γ and γ_s are negative (as depicted in Figure 72 and Figure 77) per convention, and θ is positive per convention, the following relationship holds true: $\gamma_s = (\gamma - \theta)$. In any case, the spider required at least one reading of direction relative to gravity at the onset of pursuit, and possibly two. To state this more clearly: The spider required any combination of two out of the following three readings, at the onset of pursuit: (γ_s , γ , θ), and the third value could be computed from the other two. There is a great deal of supporting evidence that these spiders take a reading on both γ (the inclination of target direction) and D (the distance of that target) when they face a target (Hill 2006a, and elsewhere in this report). The hypothesis that only gravity is used as a reference for directions in a horizontal plane suggests that only γ_s and γ are actually used.

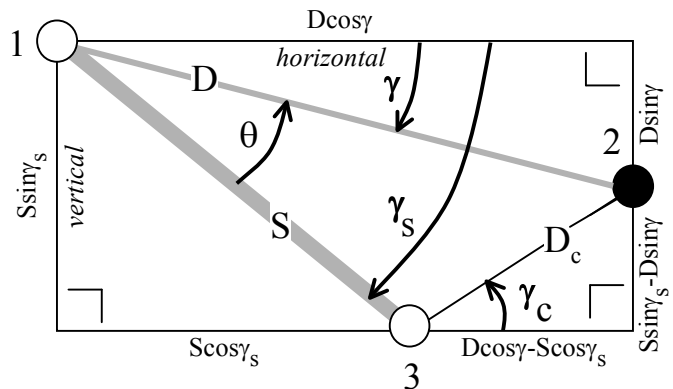

Figure 77. Analysis of reorientation in a vertical plane, based on conventions described in Figure 72. For each trial, the spider would sight the target from position 1 (at distance D), move down the bar (distance S) to position 3, and then reorient to the expected position of the prey. Formulas for computation of each segment of the perimeter are shown. These were used to develop the formula for the calculation of γ_c [3]. Note that $\gamma_s = (\gamma - \theta)$.

Based upon conventions shown in Figure 77, the calculation (or equivalent) required to accurately compute γ_c is as follows:

$$[3] \quad \gamma_c = \arctan \left(\frac{S \sin \gamma_s - D \sin \gamma}{D \cos \gamma - S \cos \gamma_s} \right)$$

The apparatus shown in Figure 78 was designed as a problem where gravity would be *required* as a reference. This supported measurement of pursuit runs on a horizontal bar, in pursuit planes of varied inclination with respect to gravity. Axial rotation of the bar during pursuit made it unlikely that the spider could use an idiothetic memory of body position to determine the inclination of the plane containing the target, as seen by the observer (Figure 78B).

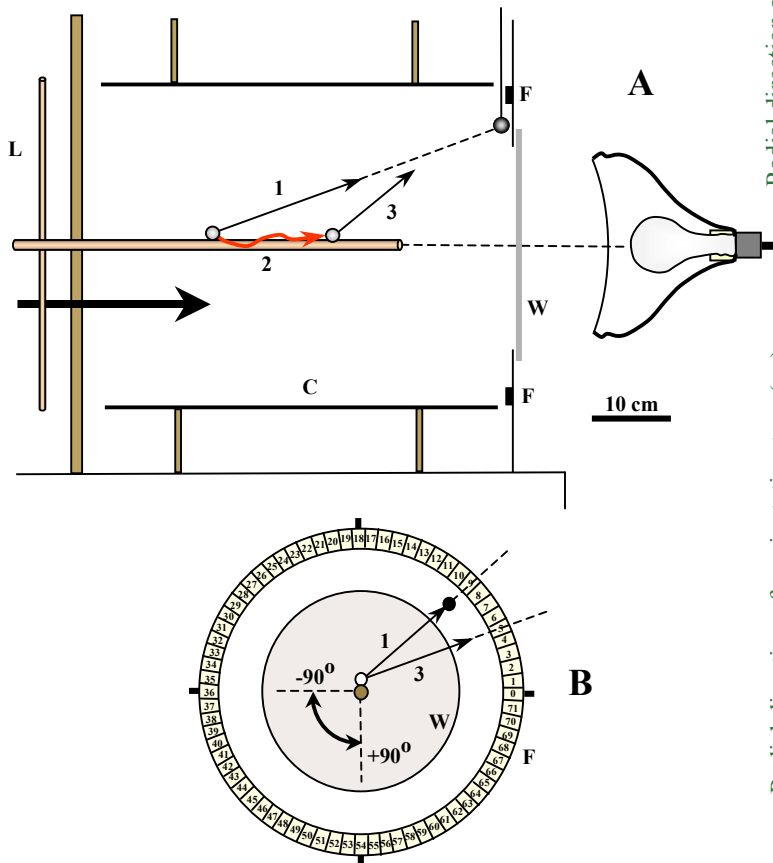

Figure 78. Vertical section (A) and observer's view (B) of apparatus used to measure the ability of *Phidippus* to reorient in the correct radial direction from a horizontal bar, corresponding to the inclined plane of pursuit. A: The lamp (at right) was centered behind a circular window (W) of opaque tracing paper, surrounded by a circumferential scale (F). During each trial, the spider faced the target (1), ran in pursuit (2), and then reoriented (3). During each pursuit, the bar was rotated with the lever (L) at left by 90° around its long axis, maintaining the horizontal position. The large arrow at left indicates the view of the observer as the spider ran toward the window, within a heavy white paper cylinder (C). B: View of the spider (open circle, on top of the center circle) as seen by the observer during pursuit. The projection of the initial orientation to the target (1) and the subsequent reorientation direction (3) were read from the circumferential scale (F) as accurately as possible. The large curved arrow indicates the convention used to define direction of rotation from the perspective of the observer. For example, during a +90° rotation, the spider would be rotated by 90° to its left during pursuit.

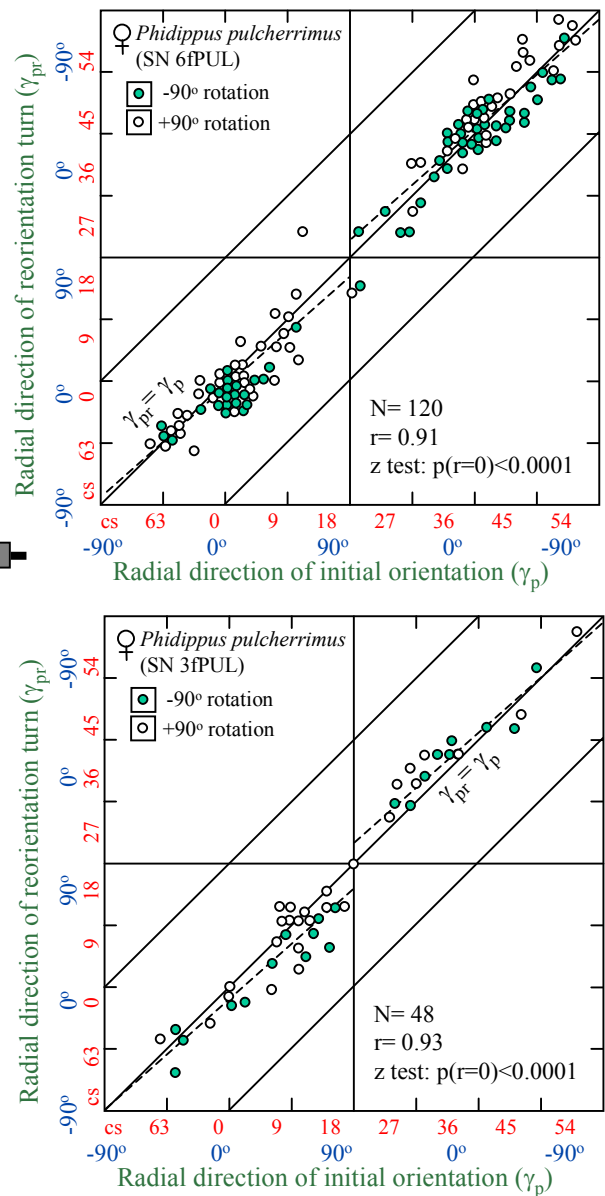

Figure 79. Results of rotation experiment described in Figure 78, for two different female *P. pulcherrimus*. The inner scales (cs) on these charts refer to directions on the F scale. The projected inclination or radial direction of the initial orientation to prey (γ_p) is the inclination of the plane of pursuit, or the inclination of the initial orientation as seen by the observer (Figure 78B). Similarly, the projected inclination of reorientation (γ_{pr}) is the inclination of the plane of reorientation, as seen by the observer. Within this plane, θ orientation could have been used to determine direction relative to the route of pursuit, but given the symmetry of the surroundings and the rotation of the bar during pursuit, only gravity was available to determine the correct inclination of the reorientation direction in this projection. As shown from these examples, spiders were able to recover from the rotation and reorient in the correct plane. Because of the rotation in each trial, idiothetic memory of body position was not sufficient and allothetic reference to gravity was required.

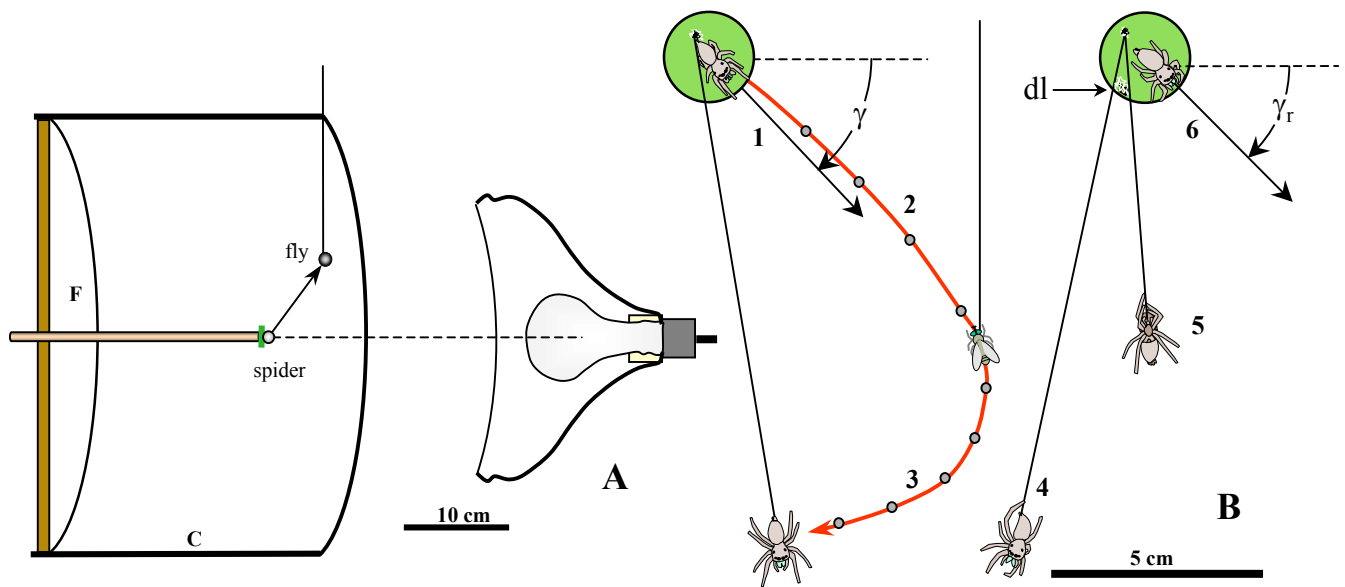

Figure 80. The jump recovery experiment. A: Vertical section, with some perspective added, of the apparatus. A circumferential scale (F) at the back of the cylinder was used to gauge radial direction faced by the spider. The heavy white paper cylinder (C), and the centered light, eliminated visual cues that could have been used to determine radial direction. An observer in a darkened room, behind the lamp, could read the direction faced by the spiders to an accuracy of about 10°. At the onset of each trial, the spider waited on a circular, 2 cm diameter platform at the end of a centered wood dowel. The standard lure was moved along a radius toward the spider, maintaining the radial direction, until the spider jumped. B: Description of the jump recovery behavior of *Phidippus*, corresponding to data presented in Figure 81. Initially the spider faced the standard lure (1), then jumped (2) and missed as the lure was quickly removed by the observer. The spider swung as pendulum, suspended by its dragline (3), and then caught the dragline with a hind leg (4) and climbed back up the dragline (5), winding it up on the way and discarding it at the end of the climb (dl). The spider then reoriented (6) to face the original target position. Note that salticids routinely wind up draglines as they climb unless they are attached at both ends. Actual values of γ and γ_r for these trials are shown in Figure 81.

Results (Figure 79) showed that spiders could recover and reorient in the correct radial direction, even after the 90° rotation in either direction during pursuit. This further supports the hypothesis that an allothetic (external) gravity reference system is used by these spiders, particularly since reliance on idiothetic body position information would have thrown them off by 90°, something that did not happen.

Based on qualitative observation of the ability of these spiders to recover their orientation to a target after a failed jump (see example in Figure 32), a series of *jump recovery* trials were run as described in Figure 80. Results (Figure 81) show how these spiders were able to remember and to use the direction of their target with respect to gravity, after a missed jump. They also tended to reorient to the same side (right or left of a vertical line) after recovery (84 of 101 trials, $P < 0.0001$).

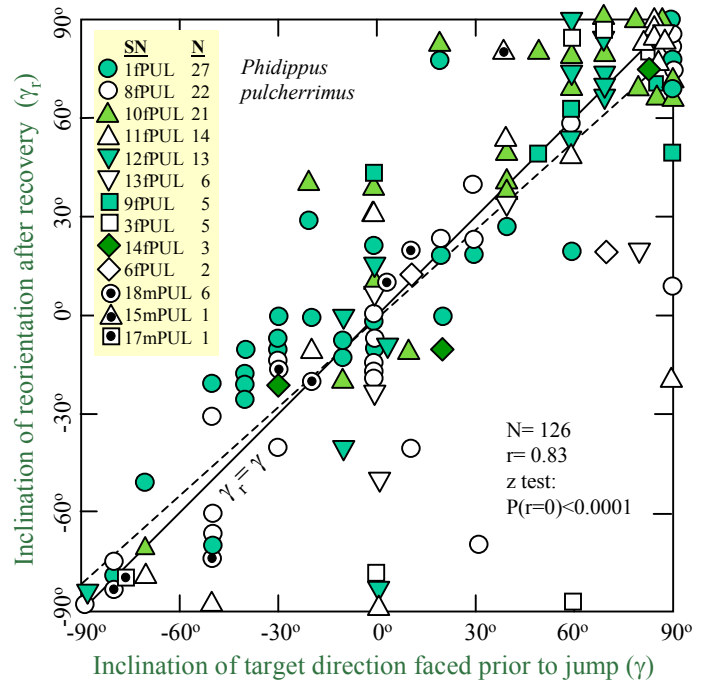

Figure 81. Pooled data from 13 individual *P. pulcherrimus* for the *jump recovery* experiment described in Figure 80. Pooling of data was required by the fact that, after missing several jumps, individuals would only jump when the target was so close that it could not be removed during the jump by the observer. The correlation of γ (the direction of the sighted target with respect to gravity) with γ_r (the direction of reorientation after the failed jump with respect to gravity) was very significant. In addition, when the prey was presented to either the right or the left of a vertical line through the spider's position, reorientation was directed toward the same side 84/101 times ($P < 0.001$).

11. Use of gravity to improve the range of targeted jumps

I recently (Hill 2006a, also see figure 67) described how salticid spiders can adjust both the magnitude of their take-off velocity and the direction of their jump relative to (above the) target direction, to improve the range of their jumps. As shown in Figure 82, the range of a 90 cm/sec jump (near the limit that has been observed for *Phidippus*) varies according to the inclination of the jump. Note that these spiders have a very limited range when jumping directly upwards, or even laterally.

To make simple measurements of the range at which these spiders would jump at prey, the apparatus described in Figure 83 was used. This allowed the mapping of the 360° jumping space around each spider in a vertical plane. The observed results (Figures 84-85) show how these spiders jumped much further toward targets that were below, rather than above, them. In effect, they attempted jumps that were within their range, given limitations depicted in Figure 82. These results, like those presented in the my recent study of jumping behavior (Hill 2006a), strongly support the hypothesis that these spiders measure and evaluate both the distance of a target (D) and the direction of that target relative to gravity (γ), when they face it.

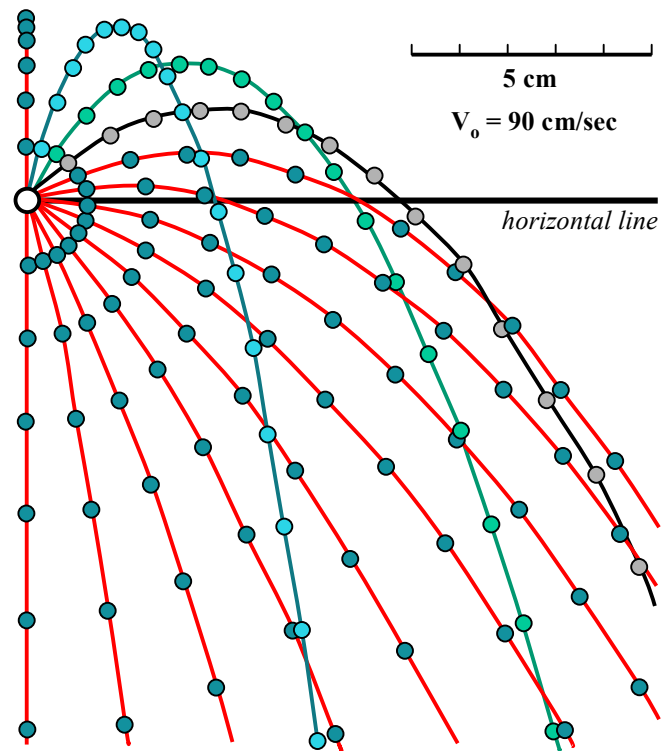

Figure 82. Potential trajectories in a vertical plane for ballistic flight by a jumping spider (or any other ballistic missile) with a take-off velocity of 90 cm/sec, near the observed maximum for these spiders. Open circles indicate positions on each flight at 15 msec intervals.

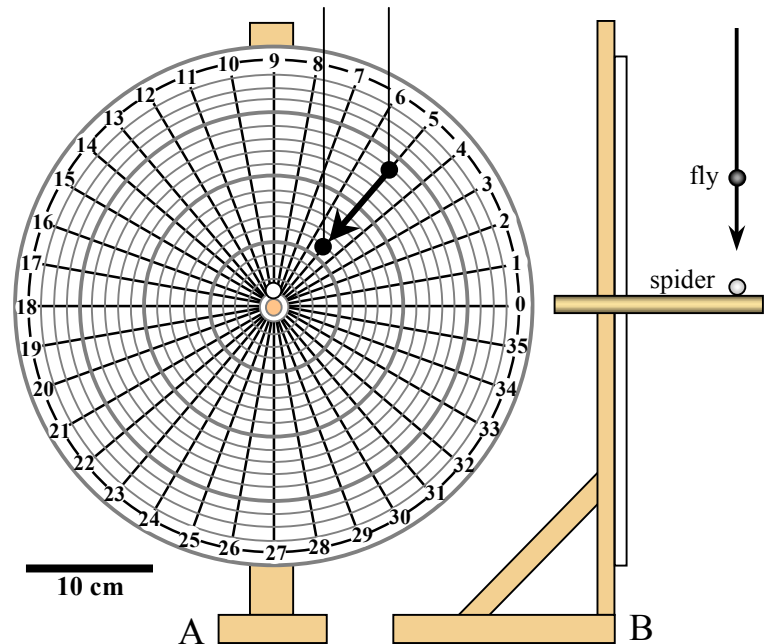

Figure 83. Front (A) and lateral (B) projections of apparatus used to map the jumping space of *Phidippus* in a vertical plane. In (B), the position of the spider (open circle) on a horizontal bar is indicated, relative to the position of the standard lure (fly). As shown in (A) the lure was moved toward the spider along a radius corresponding to a specific value of γ (direction of target relative to a horizontal line), until the spider prepared to jump. At this point, the value of D, or the distance between the axis of the bar and the target position, was recorded. Paired (γ , D) data are presented in Figures 84-85 in a graphic format that agrees with the view shown in (A). For this procedure to succeed, it was imperative that the spider was highly "motivated" or deprived of food for a sufficient interval in advance of the trials. For this to work, the lure must also be moved slowly toward the spider. This procedure can in effect test for a response at each 0.5 cm as the lure is moved.

Figure 84. Jumping spaces of two female (A and B) and two male (C and D) *P. pulcherrimus*, measured with the apparatus shown in Figure 83, as viewed from the front. The dashed lines are linear regression lines of D on γ , in polar coordinates. By definition γ (the angle between prey direction and a horizontal reference) varied from $+90^\circ$ (straight up) to -90° (straight down). Both linear regression and linear correlation (r) were based on D (radial distance to prey at the time that a jump was attempted) as a function of γ . In (C), the spider captured the lure before it could be moved out of the way in two trials (circled).

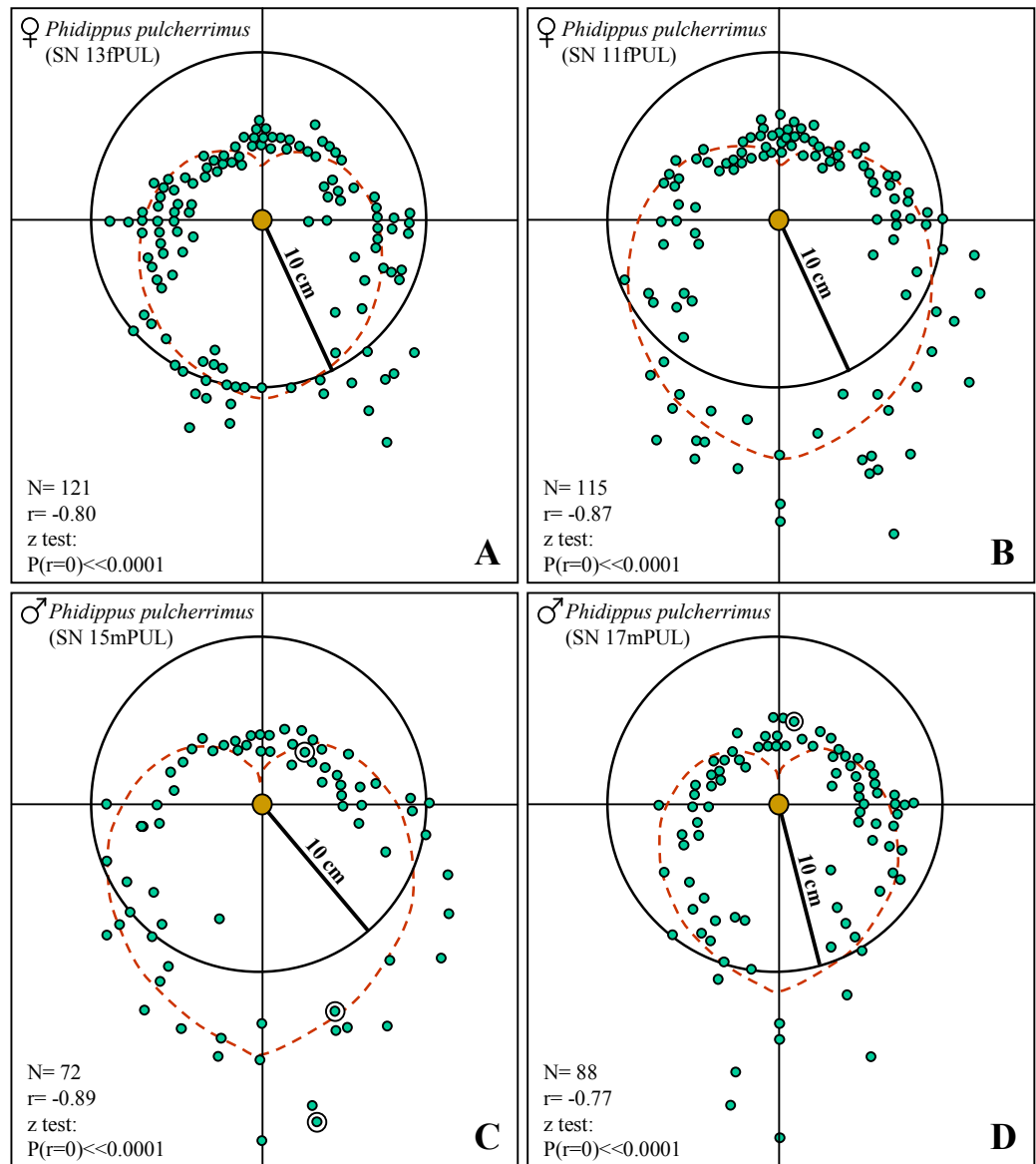
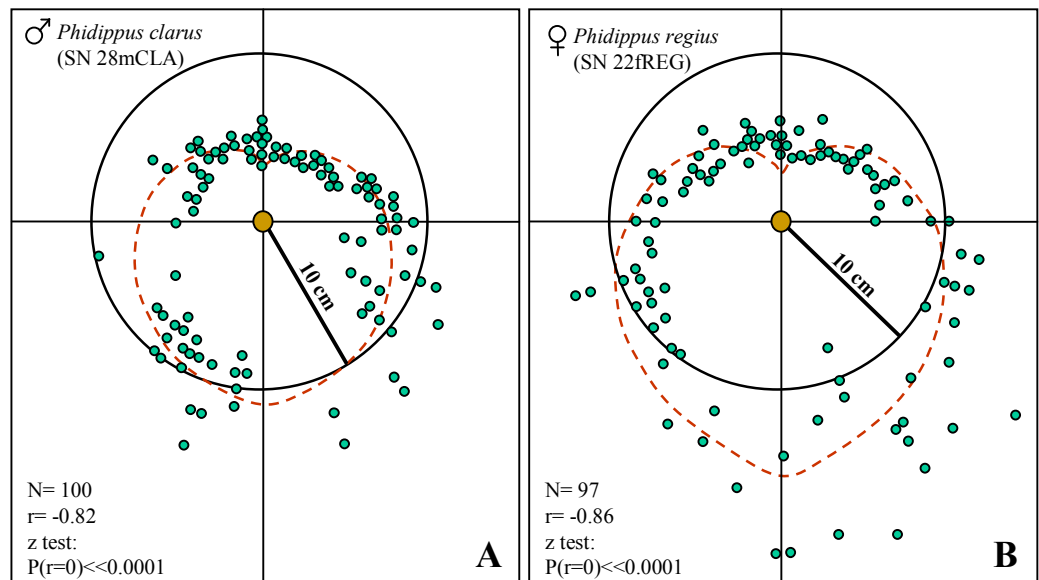

Figure 85. Jumping spaces of a male *P. clarus* (A) and a female *P. regius* (B), measured with the apparatus shown in Figure 83.



12. Use of gravity to determine the route of approach to a target

A demonstration of the impact of gravity on the direction of pursuit by a *Phidippus* is shown in Figure 86. Here the distance of the prey from the spider at the onset was close to the vertical jump threshold of about 5 cm (see Figure 84), and this individual usually ran an indirect pursuit away from the target in order to secure a higher position from which the target could be captured.

Figure 19F showed how these spiders, on a vertical plane, would move above a sighted target to a higher position where their range was sufficient to complete a jump. In the pursuits shown in Figures 27, 31, and 37A, spiders apparently determined that they did not have the range of either the prey or the branch that they were approaching, and in each case they turned down to jump to a part of a branch that was within their range. This behavior, whereby the spider turns down to jump to a lower position that is in its range, is called a *turn down jump*.

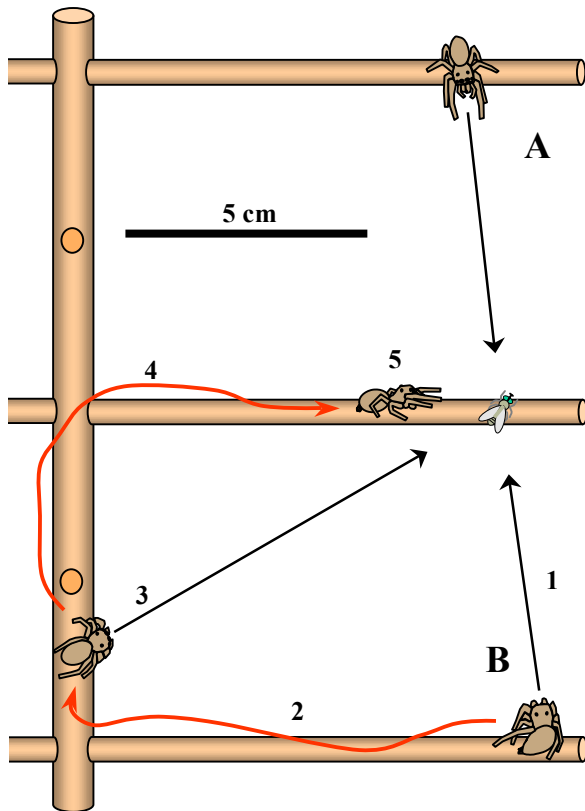

Figure 86. Influence of gravity upon the direction of approach to sighted prey by *Phidippus*. A: When above the prey at this distance, spiders attempted a direct jump. B: When below the prey at the same distance, spiders tended to run a detoured pursuit as shown here (1-4), culminating in a slow stalk (5) preparatory to a jump. Under conditions of neutral (lateral) illumination, problems A and B were presented to a female *P. pulcherrimus* (SN 8fPUL). Starting in position A relative to the target, this individual prepared for a direct jump in 60 of 60 trials. When starting in position B below the prey, the same individual attempted a direct jump in only 5 of 25 trials, and ran a detour like the one shown here in 20 of 25 trials. Compared as a contingency table, results starting from position A were significantly different from results starting from position B ($P < 0.0001$).

On a vertical rod or post, it is easy to demonstrate how these spiders will move up to a position above the target, thus gaining the range required to complete a predatory jump (Figure 87). This behavior was measured in a series of trials described in Figure 88, where spiders were started either below or above the level of the visible target, and the position from which they prepared to jump relative to that target level was recorded.



Figure 87. This adult female *Phidippus pulcherrimus* from Big Prairie in Ocala National Forest, Florida, moved up the vertical post to assume a jumping position well above the target. Note the flexion of legs IV in preparation for a jump powered by their sudden extension.

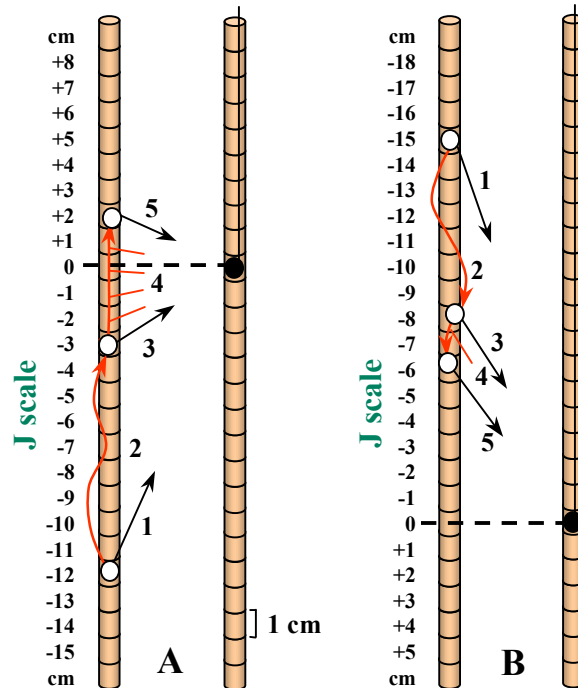

Figure 88. Selection of a jumping position relative to prey on a vertical pole. A: When approaching from below, the spider passed the closest approach to the prey ($J=0$) and jumped from a position slightly above the prey position (5, $J=+2$). B: When approaching prey from above, the spider stopped to jump well above the prey position (5, $J=-6$). Movement (4) in A and B represent intervals of side-stepping by the spider, as it positioned for a jump at (5). The J scale, in cm, indicates the number of cm before (-) or after (+) the level of the prey or target was reached by the spider. For trials with the smaller *P. pulcherrimus*, the axes of the paired poles were 6 cm apart. For the larger *P. regius*, these were 10 cm apart.

Results (Figure 89) show that these spiders consistently moved past the level of the target (+) to an elevated position when approaching from below. Faced with the symmetric problem of approach from above, spiders consistently stopped when they were well short of the level of the target (-), also at an elevated position. This example clearly demonstrates how *Phidippus* jumping spiders can position themselves with respect to gravity, to take advantage of the greater range that these positions give them to complete their jumps.

Robinson and Valerio (1977) described how *Phiale* jumping spiders also positioned themselves slightly above the level of their targets, which happened to be large *Argiope argentata* (Araneidae) spiders resting in their orb webs. This positioning allowed these spiders to traverse horizontal distances greater than 12 cm. Based on field observations, *Phiale* was also found to be a very significant predator on *Argiope* in Panama.

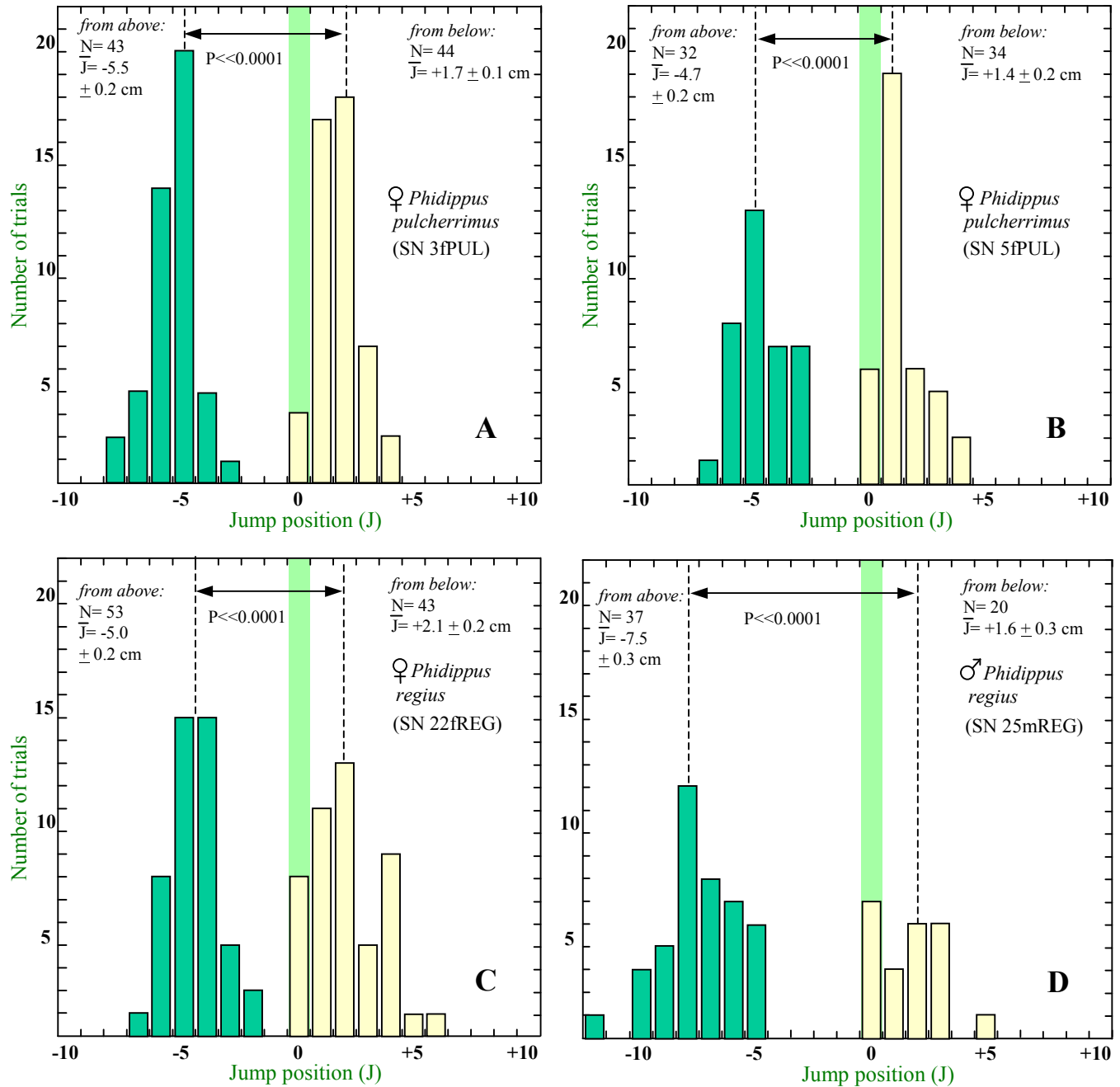

Figure 89. Frequency histograms (A-D) of J (jump position) values for approaches from above (dark green) and approaches from below (light yellow), for two *P. pulcherrimus* (A, B) and two *P. regius* (C, D). In each case the value of the average $J \pm 1$ standard error of the mean are given. Arrows indicate the highly significant ($P < 0.0001$ in each case) difference between approaches from above the prey and approaches from below the prey.

13. Visual reference to the surroundings to determine a radial direction (*image-referent orientation*)

The role of vision in the evaluation of routes of approach to prey, or in the selection of secondary objectives, has already been established. The focus of this section is on the ability of jumping spiders to use visual cues to measure or to define a direction in space.

The demonstration that these spiders could complete an accurate reorientation when running on a vertical rod in pursuit of a target (Figures 70-71) supported the hypothesis that *salticid spiders use visual cues to define the radial direction (horizontal, map or compass direction) during vertical movement*. This use of visual cues to establish direction is termed *image-referent orientation*. Previously (Hill 1978b, 1979) I used the more general term *radial orientation*, but this term is not restricted to the use of visual references.

Almost all of the qualitative examples of pursuit described previously depict situations where spiders were looking directly at plant positions to which they subsequently moved. Some of these (e.g., Figure 30) show clearly how spiders could visually maintain a radial orientation during a long descent on a stem by facing a specific branch.

During a vertical pursuit, route-referent orientation and gravity-referent orientation provide the same information with respect to direction in a vertical plane, but neither identifies a unique vertical plane (from the set of vertical planes that contain the vertical route). Evidence presented previously (Figures 73-76) supported the hypothesis that gravity-referent orientation rather than route-referent orientation is used to specify direction in a vertical plane.

On vertical routes, specification of a unique vertical plane appears to require the use of visual cues, or *image-referent orientation*. Of course, there is always a possibility that these spiders could track these movements, at least on a small scale, and use this idiothetic information to determine radial direction. The apparatus described in Figure 90 was designed to support investigation of these possibilities in a controlled setting.

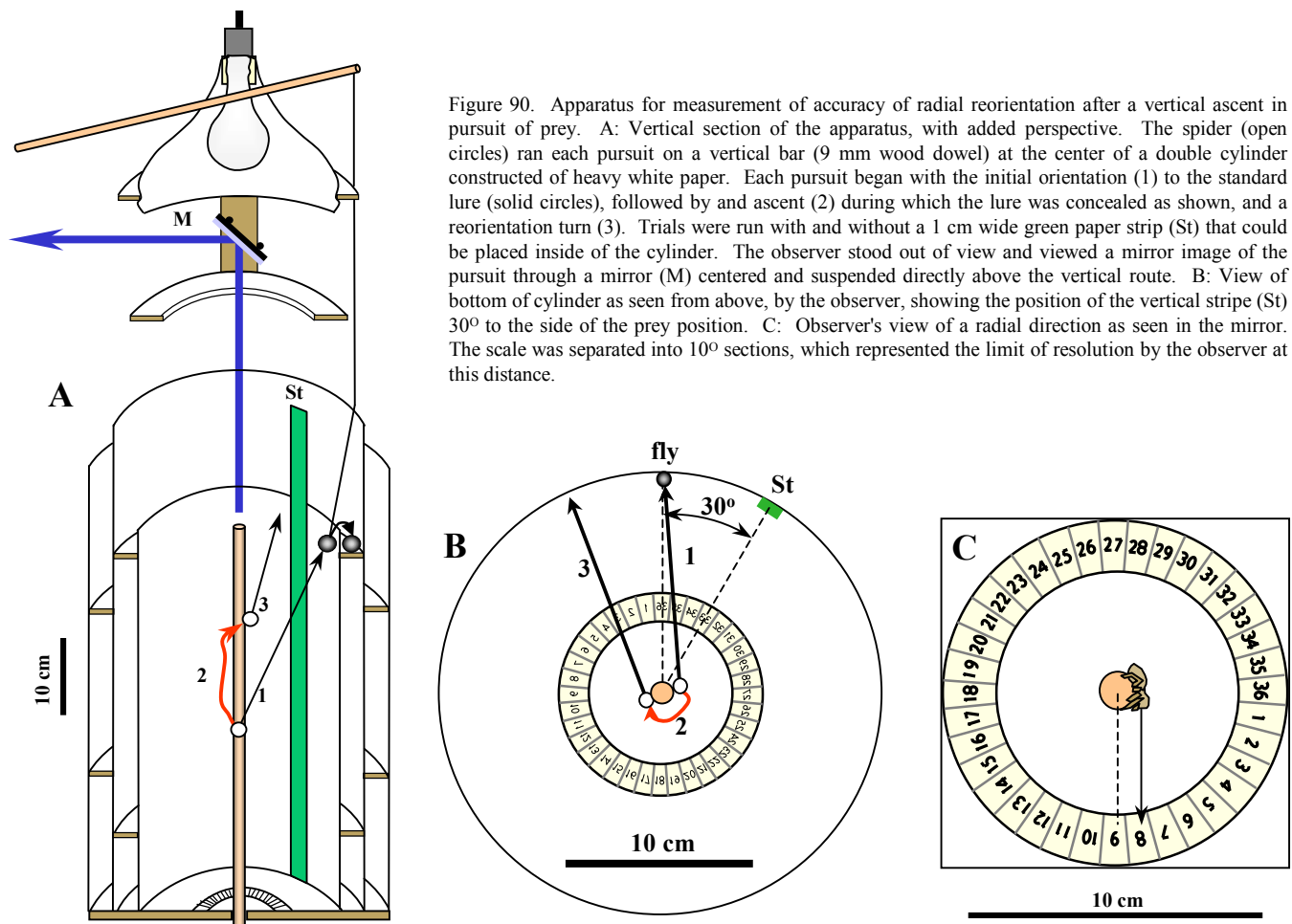

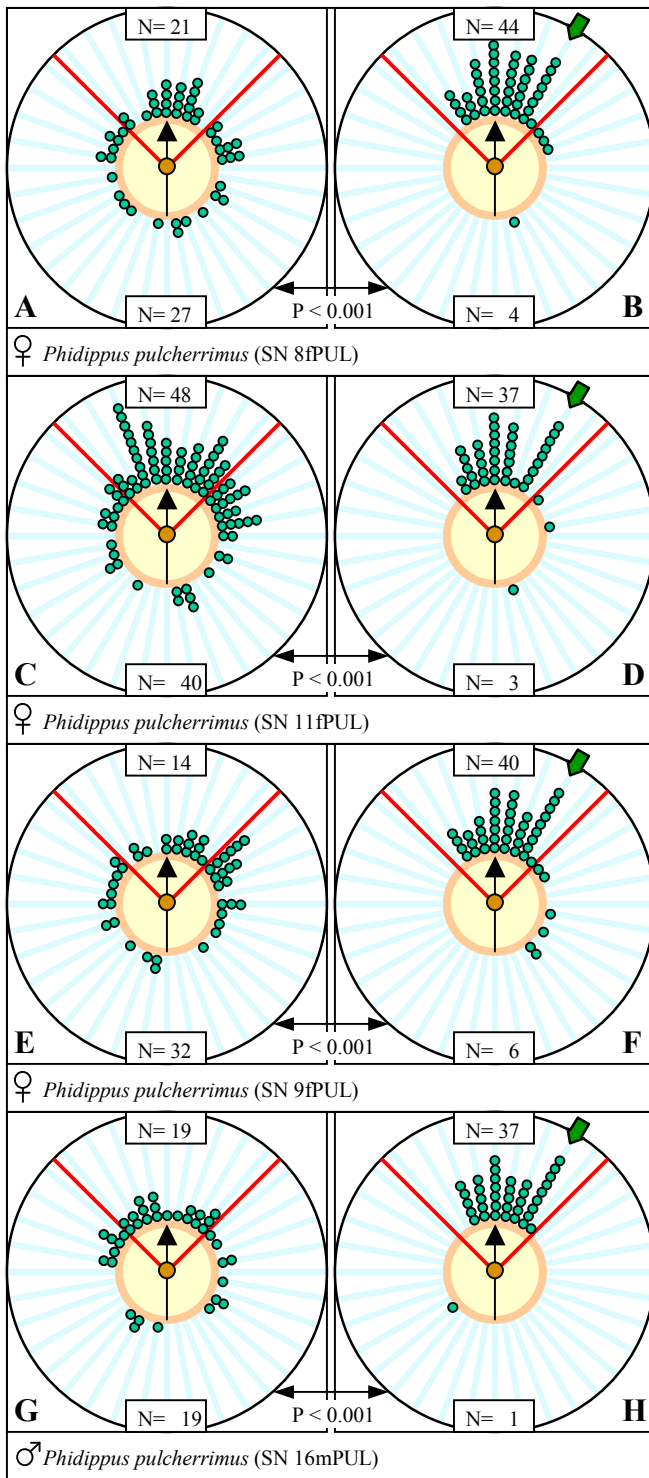

Figure 91. Accuracy of radial reorientation in an unmarked vertical cylinder (A, C, E, G), and a vertical cylinder marked with a 1 cm vertical green stripe situated (arrow) 30° to the right of the target position (B, D, F, H), for four different *P. pulcherrimus*. In each top-down view a small arrow in the center circle indicates the actual radial direction of the target. Each chart is a frequency histogram of reorientation directions faced by spiders, with each small rectangle representing one trial. For statistical analysis, these were counted as reorientations facing within 45° in either direction with respect to the target (quadrant marked at top), and all other reorientations. P values are given with respect to the null hypothesis that respective distributions (two headed arrows connect these) were the same, based upon a 2 x 2 contingency table of these counts. A significantly greater percentage of observed reorientations fell within the correct quadrant when the visual cue was present.

Results for three different species of *Phidippus* (Figures 91-92) showed that the presence of the vertical green stripe placed 30° to the right of the target had a significant impact on the accuracy of radial reorientation turns. At the same time, radial reorientation in the absence of this visual cue was not random. These spiders demonstrated a significant ability to maintain a radial direction on the route, in many trials, without the visual cue. This most likely represents the ability of these spider to maintain an idiothetic record of their own movements, as discussed previously. It was instructive to watch certain individuals continuing to turn around the pole after the initial orientation in the absence of the the vertical stripe, apparently looking for the target with no visual cues to guide them.

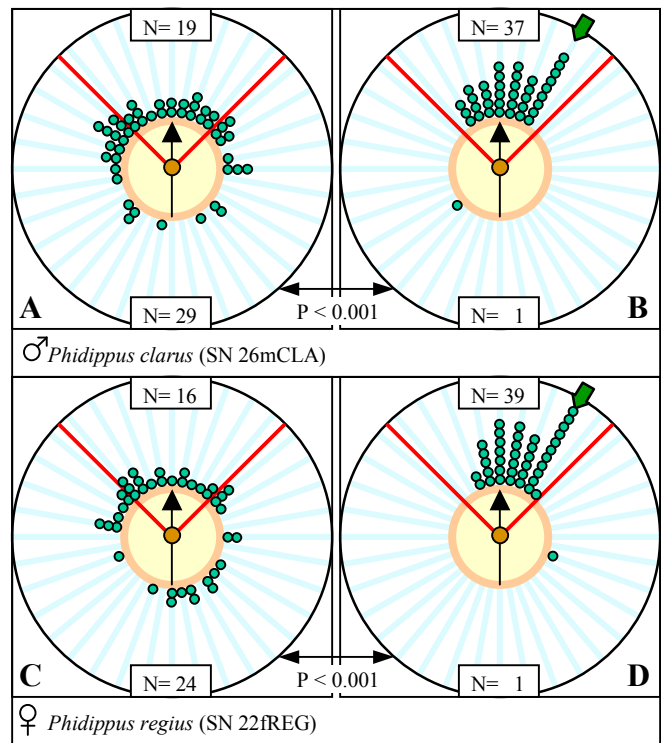

Figure 92. Accuracy of radial reorientation in an unmarked vertical cylinder (A, C), and a vertical cylinder marked with a 1 cm vertical green stripe situated (arrow) 30° to the right of the target position (B, D), for *P. clarus* (top) and *P. regius* (bottom). Results agree with those described in Figure 91.

A *rotating plant experiment* was devised to further test the role of image-referent orientation in determining a radial direction from a vertical route of pursuit. This apparatus (Figure 93) gave the spider distinct visual cues, but fewer alternatives as it forced the selection of one of four side branches during pursuit, and the apparatus (either the plant or the cylinder) could also be rotated around its vertical axis during pursuit, to interfere with idiothetic (*left and right sense*) cues related to body position. All observations were made from above the cylinder.

Results of the "control" experiment, in which the plant was rotated by 90° in either direction during pursuit, are given in Figure 94. In this situation, reorientation primarily followed the direction of the plant as it rotated. This established that the rotation itself was not substantially reducing the accuracy of reorientation turns.

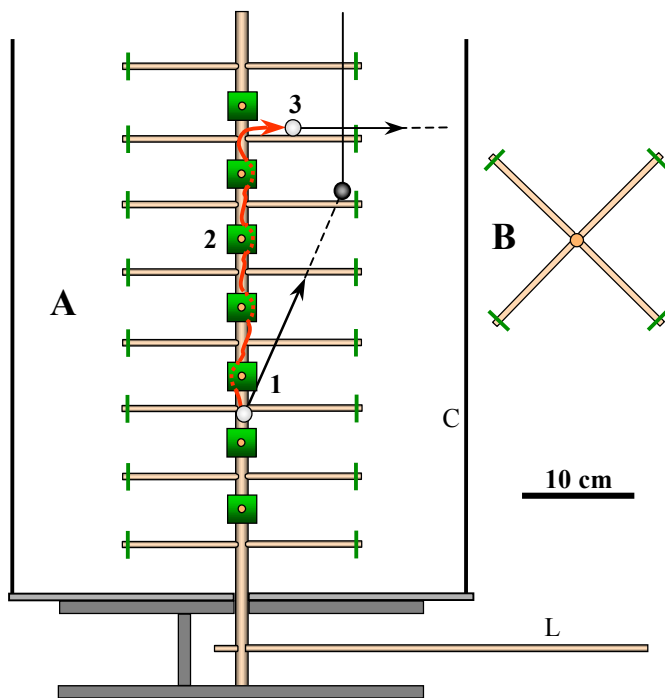

Figure 93. The *rotating plant* apparatus as seen from the side (A), and from above (B). A: The plant was constructed of wood dowels, with small green cardboard squares at the end of each "branch." The plant was surrounded by a uniform cylinder (C) constructed from heavy white paper. A lever (L) permitted rotation of the plant by 90° in either direction during pursuit. The cylinder could also be rotated by 90°. In each trial, the spider was first shown a standard lure in one of four possible directions corresponding to the branches (B). After the initial orientation (1), each spider ran a necessarily winding ascent (because of the projecting branches along the path) up the main stem of the plant, and reoriented, usually, in one of the four directions. At times, spiders would select a side branch, but then reorient in a direction perpendicular to that branch. Each pursuit began with the spider on the main stem at least 2 rungs or 12 cm below the position of the lure. At the initiation of pursuit, the lure was immediately removed, and respective rotations of either the plant or the cylinder were completed before reorientation.

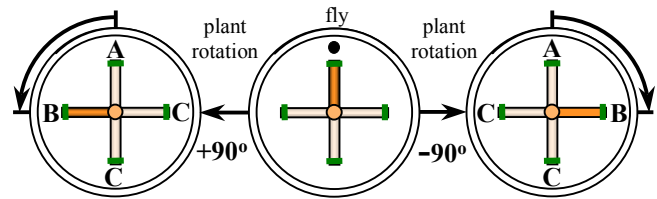

Figure 94. Diagram of control rotation of the plant within a white cylinder, with the lamp directly overhead, as viewed from above. As in subsequent experiments, approximately the same number of trials were run in either direction of rotation (+90° or -90°), with similar results which were pooled. As a convention, the direction of the initial orientation to prey is always shown to the top of the page (fly, at center above). The radial direction of the branch associated with that direction is shaded. For this control experiment, possible results, as indicated by letters A-C above, were:

- A: (*fixed reference*) Reorientation followed the original direction in space
- B: (*plant reference*) Reorientation followed the plant as it moved
- C: (*other*) Reorientation in any other direction

Results of this control rotation are shown below. Category (B) clearly dominated in a significant majority ($P < 0.001$) of the trials for each spider, indicating that spiders were able to follow the original direction on the plant in most cases, most likely through a combination of vision and idiothetic memory of their own movement as shown in the previous experiment. In addition, A results (one quadrant) were half the count of C results (covering two quadrants), a fact that agrees with the assumption that orientations in directions other than B were fairly random.

Series 1: *Enclosed in white cylinder with overhead lamp (control)*

SN	N	A	B	C
8fPUL	60	4	44	12
9fPUL	30	2	27	1
11fPUL	60	2	52	6
15mPUL	60	2	54	4
Total PUL	210	10	177	23
26mCLA	40	1	37	2

In the next series of trials, the surrounding cylinder was removed, and the plant was rotated in a series of different open settings (Figure 95, Series 2-4). When the cylinder was removed (Series 2), spiders began to use fixed or external reference cues more often. For some individuals (e.g. SN 8fPUL, a female *P. pulcherrimus*) the shift in frame of reference was almost complete. Movement of the illuminating lamp to a 45° angle to the vertical axis of the plant (Figure 95, Series 3) had an even more significant impact, resulting in use of fixed or external reference cues in more than 2/3 of the trials.

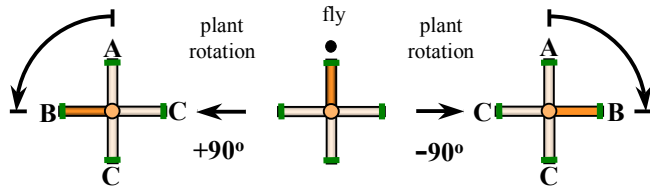

Figure 95. Diagram of rotation of the plant in an open setting (cylinder removed) as viewed from above:

- A: (fixed reference) Reorientation followed the original direction in space
- B: (plant reference) Reorientation followed the plant as it moved
- C: (other) Reorientation in any other direction

As shown below, there was a shift toward A (reorientation followed the original direction in space) in each of these situations. Series 2 results were significantly different ($P < 0.01$) than those for control Series 1 (Figure 94). Series 3 results were significantly different from either Series 1 or Series 2 ($P < 0.01$ in either case). Series 4 results were significantly different from and of the other Series (1-3) ($P < 0.01$).

Series 2: Open room with overhead light

SN	N	A	B	C
8fPUL	60	40	18	2
9fPUL	22	13	9	0
11fPUL	60	16	44	0
15mPUL	60	18	39	3
Total PUL	202	87	110	5
26mCLA	40	17	23	0

Series 3: Open room with lamp at 45° angle to plant axis

SN	N	A	B	C
8fPUL	60	44	15	1
11fPUL	60	36	22	2
15mPUL	60	40	20	0
Total PUL	180	120	57	3

Series 4: Under directional (~ 45°) sunlight under blue sky

SN	N	A	B	C
8fPUL	63	59	4	0
11fPUL	49	29	18	2
Total PUL	112	88	22	2

When this apparatus was moved outside, into similarly directional sunlight (Series 4), spiders used fixed or external cues 4/5 of the time. When compared to the control (Series 1) where spiders followed the plant as it rotated, these results strongly support the hypothesis that external visual cues, including directional lighting (when available), were preferentially used by these spiders to determine radial direction during a vertical route of pursuit.

The next series of trials (Series 5-7) were run to evaluate the use of background illumination in a controlled setting. Series 5 (Figure 96) was run as a control without rotation, to establish that these spiders did not have a preference for reorienting toward a white quadrant (they did not).

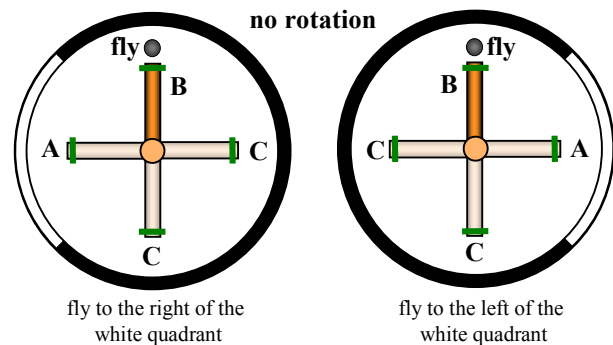

Figure 96. Diagram of plant in a cylinder with one marked white quadrant, as viewed from above:

- A: Spider reoriented to the white quadrant
- B: Spider reoriented in the original direction
- C: Spider reoriented to one of the other black quadrants

Spiders reoriented in the original direction almost all of the time, and did not display any tendency to orient toward the white quadrant (A not different from C).

Series 5: Fixed plant with white quadrant to the side (control)

SN	N	A	B	C
8fPUL	60	2	56	2
11fPUL	65	2	60	3
Total PUL	112	4	116	5

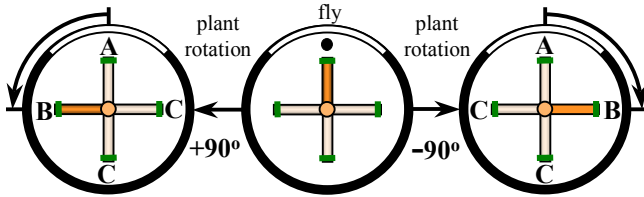

Figure 97. Diagram of rotation of the plant within a cylinder containing one white quadrant, in the initial direction of the target. As in the control (Figure 94, Series 1), an incandescent lamp was directly overhead, in alignment with the vertical axis:

- A: (fixed reference) Reorientation followed the original direction in space
- B: (plant reference) Reorientation followed the plant as it moved
- C: (other) Reorientation in any other direction

When compared to the control (Series 1), there was a significant ($P < 0.01$) shift toward A, use of a fixed or external reference. The impact of the white quadrant as a visual cue compared to the impact of removing the cylinder seen in Series 2.

Series 6: Rotation of plant in cylinder with white quadrant

SN	N	A	B	C
8fPUL	77	35	40	2
15fPUL	80	22	58	0
Total PUL	157	57	98	2

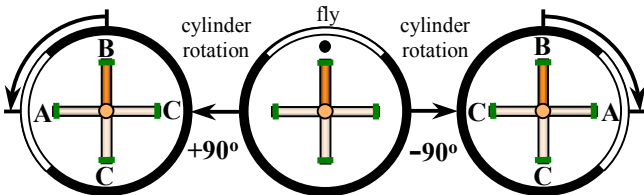

Figure 98. Diagram of rotation of a cylinder containing one white quadrant, initially in the direction of the target, around a fixed plant. As in the control (Figure 94, Series 1), an incandescent lamp was directly overhead, in alignment with the vertical axis:

- A: Reorientation followed the white quadrant as it moved
- B: Reorientation followed the fixed plant
- C: (other) Reorientation in any other direction

For this experiment (Series 7), the comparison was between A and C. Although most reorientations were still based on the plant itself (B, fixed in this case), a significant number followed the movement of the white cylinder (A), when compared to the number that turned laterally in the opposite direction (C, in part). This clearly demonstrated that spiders could follow background illumination associated with radial direction.

Series 7: Rotation of cylinder with white quadrant around fixed plant

SN	N	A	B	C
8fPUL	65	26	37	2
11fPUL	65	22	42	1
15mPUL	61	9	52	0
Total PUL	191	57	131	3

Rotation of the plant within a cylinder marked by a white quadrant (Figure 97, Series 6), resulted in a significant shift from the control (Figure 94, Series 1) toward use of the fixed or external reference. When the plant was fixed, and the cylinder bearing a white quadrant in the initial direction of the target was rotated, spiders followed the white quadrant a significant number of times (Figure 97, Series 7). This demonstrated that, without moving the plant and the spider during the pursuit, one can shift the spider's frame of reference by moving the pattern of background illumination. Note that the control for this demonstration (Figure 96) showed that spiders had no intrinsic tendency to follow a white background.

A related experiment (Figure 99, Series 8) was designed as a potential demonstration of the ability of these spiders to use the polarization of skylight (patch of blue sky) as a reference for direction. This was conducted on top of a building to eliminate most (but not all, since the sun had to be shaded) horizon cues, at times when the sun was relatively close to the horizon, to maximize the polarization effect (scattering angle near 90° , see Wehner 2001). There was absolutely no impact on the ability of these spiders to determine the direction of reorientation. Spiders reoriented with respect to the immediate plant configuration, as if this information did not exist.

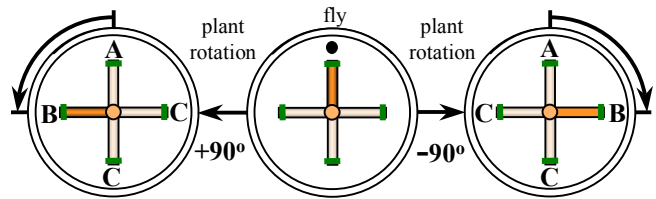

Figure 99. Diagram of rotation of the plant within a uniform white cylinder, under a clear blue sky. Direct illumination from the sun was blocked by the observer and a wall to the west of the apparatus. The solar altitude was low, varying from 30° to 5° during the course of these trials. During each initial sighting of the prey, the spider had a clear view of blue sky in the background, at the zenith. Other than illumination, this experiment was very similar to the control (Figure 94, Series 1).

- A: (fixed reference) Reorientation followed the original direction in space
- B: (plant reference) Reorientation followed the plant as it moved
- C: (other) Reorientation in any other direction

These results did not differ in any way from those obtained for the control. Note the agreement of A with C (given that two quadrants were counted in C) results, as described for the control. This indicates that the patch of blue sky visible overhead, combined with inevitable, small horizon cues related to the blocking of the sun, had no impact on the reorientation of these spiders. Note that spiders were facing this blue sky directly as they ascended.

Series 8: Rotation of plant in cylinder under patch of blue sky

SN	N	A	B	C
11fPUL	91	5	75	11
15fPUL	72	4	59	9
Total PUL	163	9	134	20

These negative findings were very similar to those reported recently (Stalleicken, Labhart, Wehner, Frost, and Mouritsen 2005) for orientation by migrating monarch butterflies (*Danaus plexippus*). These careful studies were unable to reveal any use of polarization cues by these butterflies. The authors also mentioned the horizon effect related to blocking out the sun that I described above. They concluded that the relative position of the sun and associated light gradients were sufficient to explain the behavior of these butterflies. This compares with the experimental results for salticid spiders reported here. Wehner (2001) suggested that individual samples ("patches of sky") may not be of as much use as multiple samples collected simultaneously from orthogonal directions.

I conducted several related experiments using the simple apparatus described in Figure 90, either under blue sky or beneath a polarizing filter under a lamp in the laboratory. In all trials I have been unable to find any indication that *Phidippus* can use a polarization (*e-vector*) pattern to determine a radial direction from a vertical route.

It is possible that this information is useful in some behavioral context. Given the wide variety of other cues that are available, including variation in background illumination, and the incidence of direct sunlight, it may be very difficult to demonstrate the use of this information in salticids. There have been very few reported demonstrations of the actual use of polarized light patterns by spiders (e.g., Gorner 1962, Henton and Crawford 1966). In reality, it is almost impossible to separate *e-vector* cues from horizon cues and other visual cues (e.g., sky illuminance) in a natural environment.

Salticid spiders commonly orient in *all* directions relative to the horizon, so one would not expect to find retinal specializations related to the perception of the *e-vector* of polarized skylight as described for ground dwelling spiders that may maintain a horizontal orientation most of the time (Dacke, Nilsson, Warrant, Blest, Land, and O'Carroll 1999, Dacke, Doan, and O'Carroll 2001).

The use of background visual patterns (or relatively fixed visual references at a distance) to establish a radial direction has also been observed in many other spiders, including the araneid *Araneus diadematus* (Peters 1932) and the agelenid *Agelena labyrinthica* (Bartels and Balzer 1928, Bartels 1929, Gorner 1958, 1966, Dornfeldt 1975a, 1975b).

Figure 100. Complementarity of reference systems available for the determination of direction in three-dimensional space. A: The combination of direction relative to a route of movement (θ) with a specified radial direction (R) are sufficient to define a unique direction, for any orientation in space. These reference systems would be available in the absence of gravity. B: On a horizontal route, gravity defines both the horizontal plane ($\gamma = 0$) and thus provides a reference radial direction (R), which is complemented by route-referent orientation (θ). C: When a route is vertical, route-referent (θ) and gravity-referent (γ) provide the same information and are therefore insufficient to define a specific direction. In this case, additional information is needed to define a radial direction. D: In this view a non-vertical route slopes away from the observer toward the top. The combination of θ and γ specifies two different directions, as shown here. This ambiguity can be resolved by the spider's sense of right and left "handedness," as also demonstrated on the horizontal bar. On a non-vertical route θ and γ are always sufficient to determine direction (See also Figure 101).

14. Movement and orientation in three dimensions

As shown in Figure 100, at least two different reference directions are required to specify a unique direction in space. In this paper, three different reference systems that are used by salticid spiders for this purpose were studied:

- (1) Direction of the immediate route (*route-referent*)
- (2) Direction of gravity (*gravity-referent*)
- (3) Direction of a nearby pattern or object (*image-referent*)

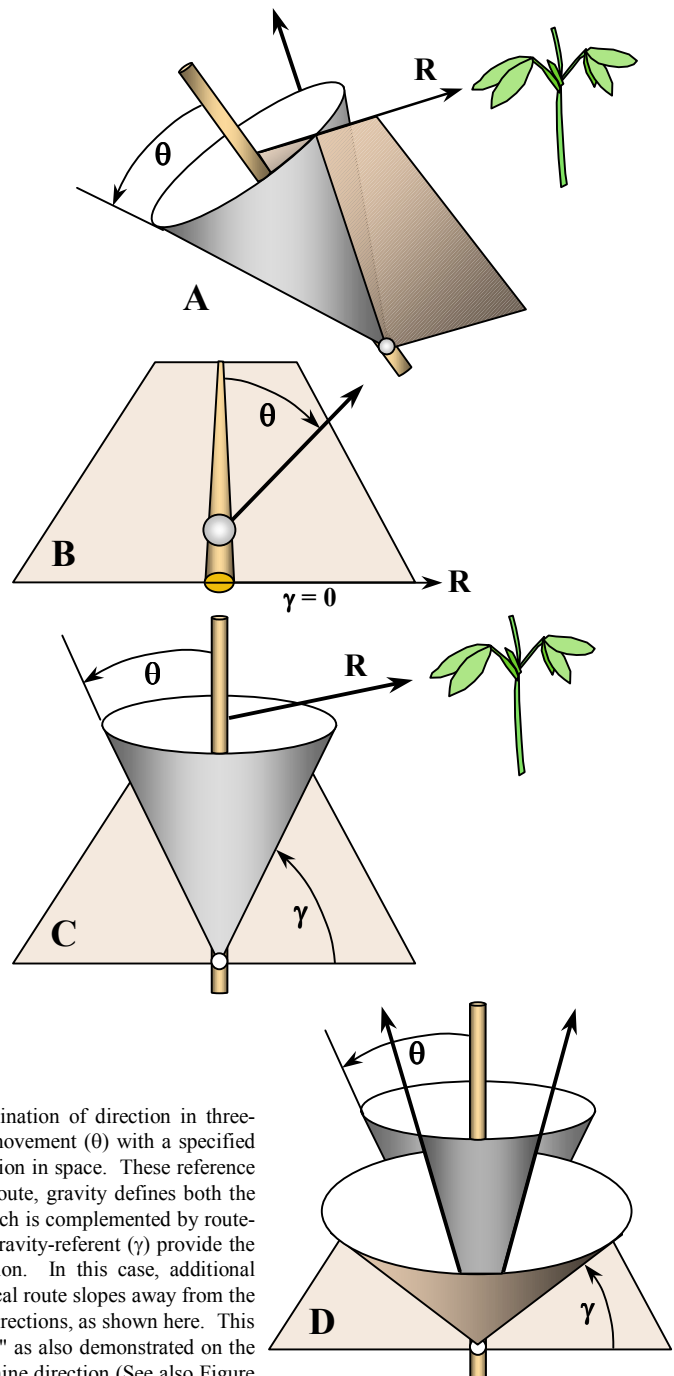

The working hypotheses related to the use of these directional reference systems can be supported by these studies are:

[H-1] *Route-referent* orientation, based on measurement of how far a sighted location is to either the left or to the right of a direction or route of movement, is used within a horizontal plane. Recognition of route direction is based on a combination of idiothetic (internal sensory or motor measurement of bodily motion, or *path-integration*) and allothetic (at least physical contact) cues.

[H-2] *Gravity-referent* orientation, based on measurement of direction with respect to the force of gravity, is employed in the measurement of vertical (up and down) direction, or relative elevation within a vertical plane.

[H-3] *Image-referent* orientation is used to determine a radial direction within a horizontal plane, and it is required to establish horizontal direction from positions on a vertical route, including a position on a vertical stem. Directional lighting, differences in background light intensity, and the presence of specific objects in the visual field are all used for this purpose.

[H-4] Within the context of these reference systems, *Phidippus* spiders can assess both the relative direction and distance of a target, and the relative direction and distance of their own movement.

[H-5] *Phidippus* spiders can compensate for their own movement to determine the relative direction of prey when they move to a new location. In effect, *they can subtract the vector of their own movement from the vector of the initial target position to compute a new vector of target position.*

A related hypothesis that has been suggested by these observations is:

[H-2.1] These spiders use *only* gravity-referent orientation to determine the vertical component of direction.

The evidence for hypothesis [H-2.1] comes primarily from the rotation experiment described in Figure 72, where spiders used gravity for this purpose *to the exclusion of all other cues*. As discussed previously, and as shown in Figure 100A, gravity is not absolutely *required* in many situations where it is definitely used, and it is likely that these spiders *could* use a combination of visual-referent and route-referent cues in the absence of gravity. The evidence for this prediction lies in the fact that these spiders have the ability to use each of the other two reference systems independently of gravity, and in the absence of gravity there is every reason to believe that they would be able to continue this behavior.

In the presence of gravity, however, it is not possible to test the prediction that route-referent and visual-referent information could be used together by a spider to define a direction in space.

Phidippus were presented with a simple pursuit problem on a sloping rod, as shown in Figure 101. This configuration differs from previous experiments in that the plane of pursuit was neither horizontal nor vertical, but oblique with respect to a horizontal plane. The rod was surrounded by a partial cylinder to create a uniform white background and to eliminate obvious visual cues in the direction of the target, other than those that could be provided by the rod itself. Based on the previous demonstration that these spiders would neglect visual cues from their surroundings in an open room when running pursuits on a horizontal bar (Figures 49-51), it is reasonable to assume that the observed accuracy of reorientation was due to a combination of route-referent and gravity-referent orientation.

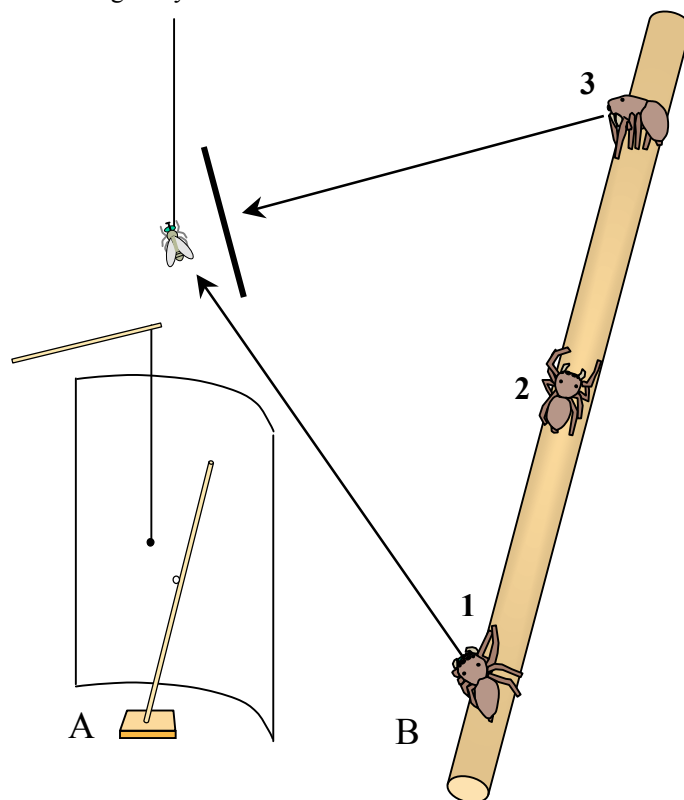
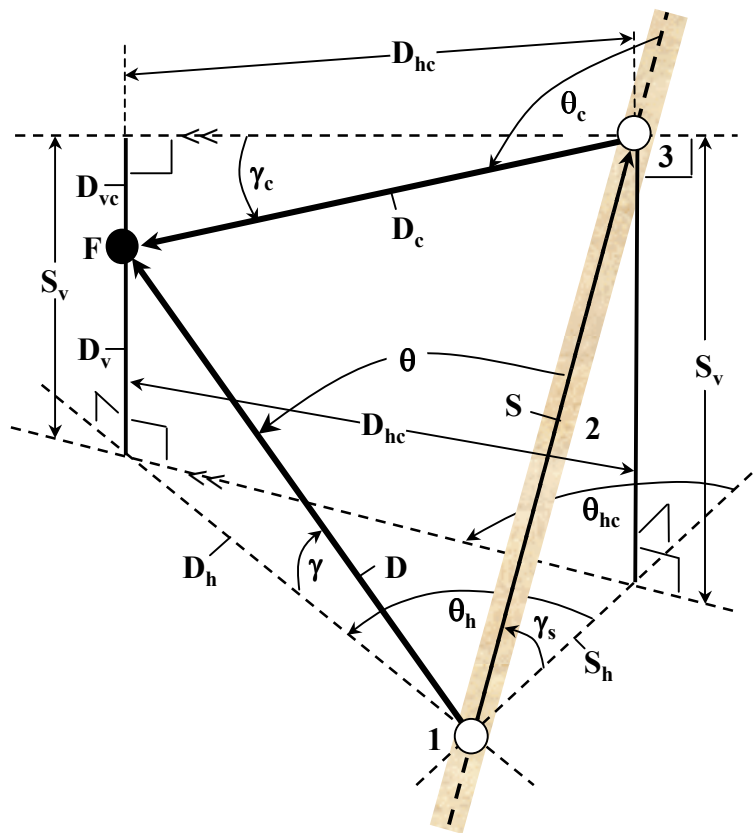

Figure 101. Ascending pursuit on a sloping bar (wooden dowel) in an oblique plane of pursuit, as defined by the original direction of the prey and the direction of movement of the spider. In qualitative trials, spiders ran on dowels inclined at angles ranging from 45°-60° with reference to the horizontal. As in other pursuits on the bar, a facing turn toward the target (1) was followed by a run as the lure was removed, ending with a reorientation turn (3). Compensation for movement in these trials was clearly visible in the form of a very significant increase from θ (an acute angle) to θ_r (a much larger, obtuse angle), and the very significant change from a large positive γ (looking up) to a large negative γ (looking down). With reference to the vertical plane containing the bar, the correct "handedness" (reorientation to the right or to the left of the bar) was consistently demonstrated. A partial cylinder of heavy white paper was used to block out visual cues in the direction of the target and pursuit as shown in A. Mathematical conventions used to analyze the relationship of route-referent and gravity-referent orientation in this problem are described in Figure 102.

Figure 102. Conventions related to specification of dimensions for the oblique plane of pursuit problem described in Figure 101. Note the oblique triangle bounded by S, D, and Dc, the horizontal reference triangle bounded by Sh, Dh, and Dhc (representing the projection of the oblique triangle on a horizontal plane), and the vertical reference rectangle bounded by Sv and Dhc. Also note position of the spider at start of pursuit (open circle, 1), position of the spider at end of pursuit (open circle, 3) and position of the lure (F, removed during pursuit).

1	initial position of spider (facing target)
2	position of spider during pursuit
3	final position of spider (reorienting to target)
D	initial distance of target from spider
Dc	final distance of target from spider
Dh	horizontal component of d
Dhc	horizontal component of dc
Dv	vertical component of d
Dvc	vertical component of dc
F	standard lure (removed during pursuit)
S	distance of pursuit
Sh	horizontal component of s
Sv	vertical component of s
θ	route-referent direction of target at start
θ_c	route-referent direction of target at end
θ_h	horizontal component of θ
θ_{hc}	horizontal component of θ_c
γ	initial inclination of target direction
γ_c	final inclination of target direction
γ_s	inclination of route or direction of pursuit



Conventions used in the analysis of pursuit on this oblique rod are given in Figure 102. There are many ways to approach the calculation of critical components of the reorientation turn (θ_c , γ_c) from required information (D , θ , γ , γ_s , S), all of which are mathematically equivalent.

In general,

$$(\theta_c, \gamma_c) = \mathbf{f}(D, \theta, \gamma, \gamma_s, S)$$

Note that the reorientation vector is equal to the initial orientation vector minus the movement (pursuit) vector:

$$\vec{D}_c = \vec{D} - \vec{S}$$

The computation of θ_c that we reviewed with respect to orientation in a horizontal plane applies irrespective of the orientation of the route in space, and no gravity-referent information is required for this calculation:

$$[1] \quad \theta_c = \arctan \left(\frac{\sin \theta}{\cos \theta - \left(\frac{S}{D}\right)} \right)$$

Development of this formula for an obtuse reorientation angle (θ_c) is shown in Figure 103. The same formula applies whether respective angles are acute or obtuse.

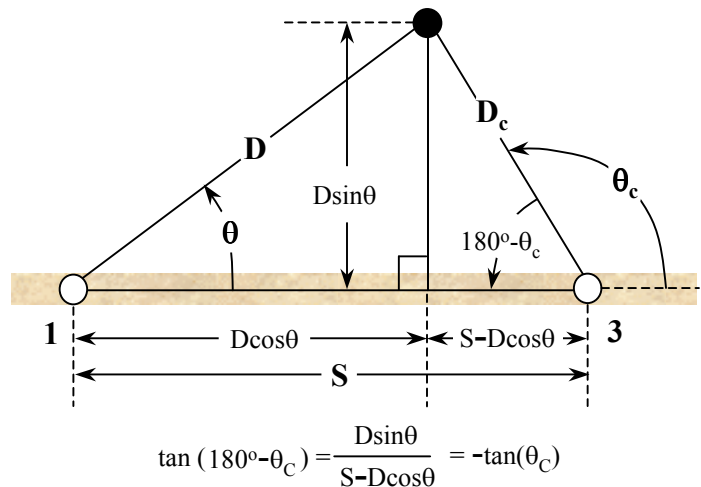

Figure 103. Trigonometric development of the formula [1] for calculation of a route-referent reorientation direction (θ_c) from D , θ , and S , based on an obtuse reorientation angle. This calculation is applicable for any orientation of a route of pursuit.

The distance of the target position (D_c) from the new reorientation position is a function of the same input variables:

$$[4] \quad D_c = +\sqrt{(S - D \cos \theta)^2 + (D \sin \theta)^2}$$

Or, simplified:

$$[5] \quad D_c = +\sqrt{D^2 - 2DS \cos \theta + S^2}$$

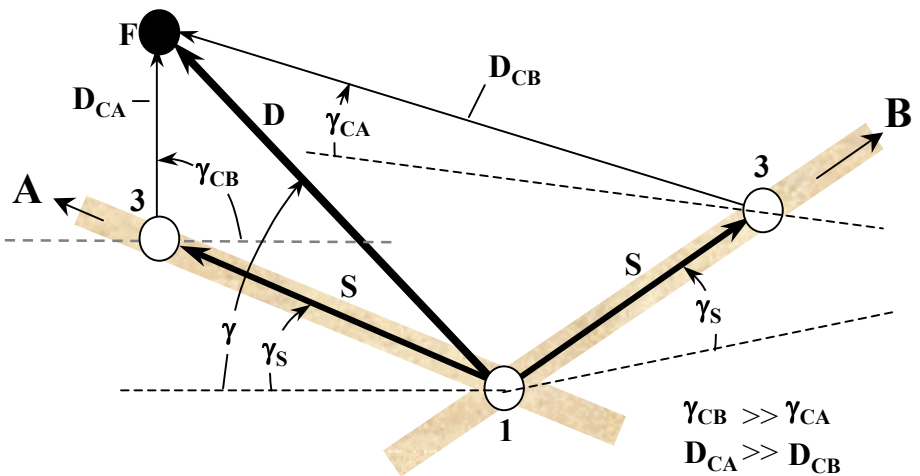

Figure 104. On an oblique plane of pursuit, route-referent information is required to determine the correct direction for reorientation with respect to gravity. Here values for D , γ , γ_s , and S are the same for pursuits in both directions A and B. Yet the value of γ_c is near 90° in A, and γ_c is about 20° in B. To complete the calculation of γ_c , route-referent information is needed to specify the direction of the route relative to the direction of the target. In addition, D_c is radically different for the two directions of approach.

This indicates that, if a spider has the information required to calculate the direction of reorientation toward a target after moving to a new position, then it also has the information required to calculate the distance of the target from that new position. An additional hypothesis that incorporates both ideas is:

(7) During each pursuit, jumping spiders update an *internal representation* or memory of the relative location (relative direction and the distance) of a target.

Based on Figure 103, we can look at an alternative representation for the calculation of θ_c in terms of D_c :

$$[6] \quad \theta_c = \arcsin \left(\frac{D \sin \theta}{D_c} \right)$$

Or in an expanded form:

$$[7] \quad \theta_c = \arcsin \left(\frac{D \sin \theta}{+\sqrt{D^2 - 2DS \cos \theta + S^2}} \right)$$

Mathematically, [7] does not differ from [1]. Equation [7] is of interest, however, because it incorporates the calculation of D_c into the calculation of θ_c . In this respect, this equation is very similar to that used to calculate γ_c (see [8] below).

Previously, we discussed a simple formula for the calculation of the gravity-referent reorientation direction for a pursuit which took place in a single vertical plane, as defined by the direction of D and S :

$$[3] \quad \gamma_c = \arctan \left(\frac{S \sin \gamma_s - D \sin \gamma}{D \cos \gamma - S \cos \gamma_s} \right)$$

As shown in Figure 104, this equation is insufficient for an oblique pursuit, where information with respect to the direction of the route relative to the target (route-referent information) is also required to compute γ_c .

Based on conventions shown in Figure 102,

$$S_v = S \sin \gamma_s$$

$$D_v = D \sin \gamma$$

$$D_{vc} = S_v - D_v$$

$$\sin \gamma_c = \frac{-D_{vc}}{D_c} \quad [\text{down: negative by convention}]$$

Therefore:

$$D_{vc} = S \sin \gamma_s - D \sin \gamma$$

$$\gamma_c = \arcsin \left(\frac{-D_{vc}}{D_c} \right)$$

As shown previously,

$$[5] \quad D_c = +\sqrt{D^2 - 2DS \cos \theta + S^2}$$

Therefore,

$$[8] \quad \gamma_c = \arcsin \left(\frac{D \sin \gamma - S \sin \gamma_s}{+\sqrt{D^2 - 2DS \cos \theta + S^2}} \right)$$

A comparison of equations [5], [7], and [8], shows clearly how the calculation of D_c is implicit in the calculation of both θ_c and γ_c . The calculation of θ_c and D_c does not require any gravity-referent information, but the calculation of γ_c *does* require route-referent information.

The earlier analysis of gravity-referent reorientation in a vertical plane (Figure 77) also allowed for the calculation of D_c with no reference to θ :

$$[9] \quad D_c = +\sqrt{(D \cos \gamma - S \cos \gamma_s)^2 + (S \sin \gamma_s - D \sin \gamma)^2}$$

This only works when the plane of the pursuit, as defined by the route of pursuit and the direction of the target, is situated in a vertical plane. In all other situations, θ is required information, and in fact information related to the inclination of the target (γ) and the route of pursuit (γ_s) is superfluous and falls out of the mathematics as uninformative with respect to the calculation of D_c (see also Figure 104, which highlights the ambiguity that this information would introduce to the calculations).

Separation of horizontal and vertical components

The strict adherence of these spiders to gravitational cues when determining direction in a vertical plane (depicted in Figures 72-76), suggested that only the horizontal component of direction was based on route-referent orientation. In that experiment, the horizontal component of prey direction did not change during the pursuit, but remained straight ahead ($\theta_h = 0^\circ$, not to the right or to the left). In addition, the great importance of *relative elevation* as a determinant of salticid behavior (as depicted, for example, in Figures 85-89) makes the hypothesis that these spiders process information related to horizontal and vertical movement in different ways more plausible. Modified hypotheses are:

[H-6] Distance or relative location information, including distance of viewed objects and distance of movement by the spider, is separated by the salticid into vertical (*relative elevation or height*) and horizontal components (*map distance and map or compass direction*), for tracking and also as determinants of subsequent behavior.

[H-2.2] Gravity is used *almost exclusively* as the reference system for determination of the vertical component of direction (*relative elevation or height*). This includes definition of a horizontal reference plane.

[H-1.1] Salticids use both the immediate route or direction of movement (route-referent cues, including idiothetic *right and left sense* of body position) to determine horizontal direction (*map direction*).

[H-3.1] Visual-reference cues are used when route-referent cues are ambiguous or absent, to determine horizontal direction.

The separation of vertical and horizontal components may help us to understand the behavior of these spiders, but, as shown in Figure 105, it does not alter the previous analysis of essential information. Mathematically, it is equivalent.

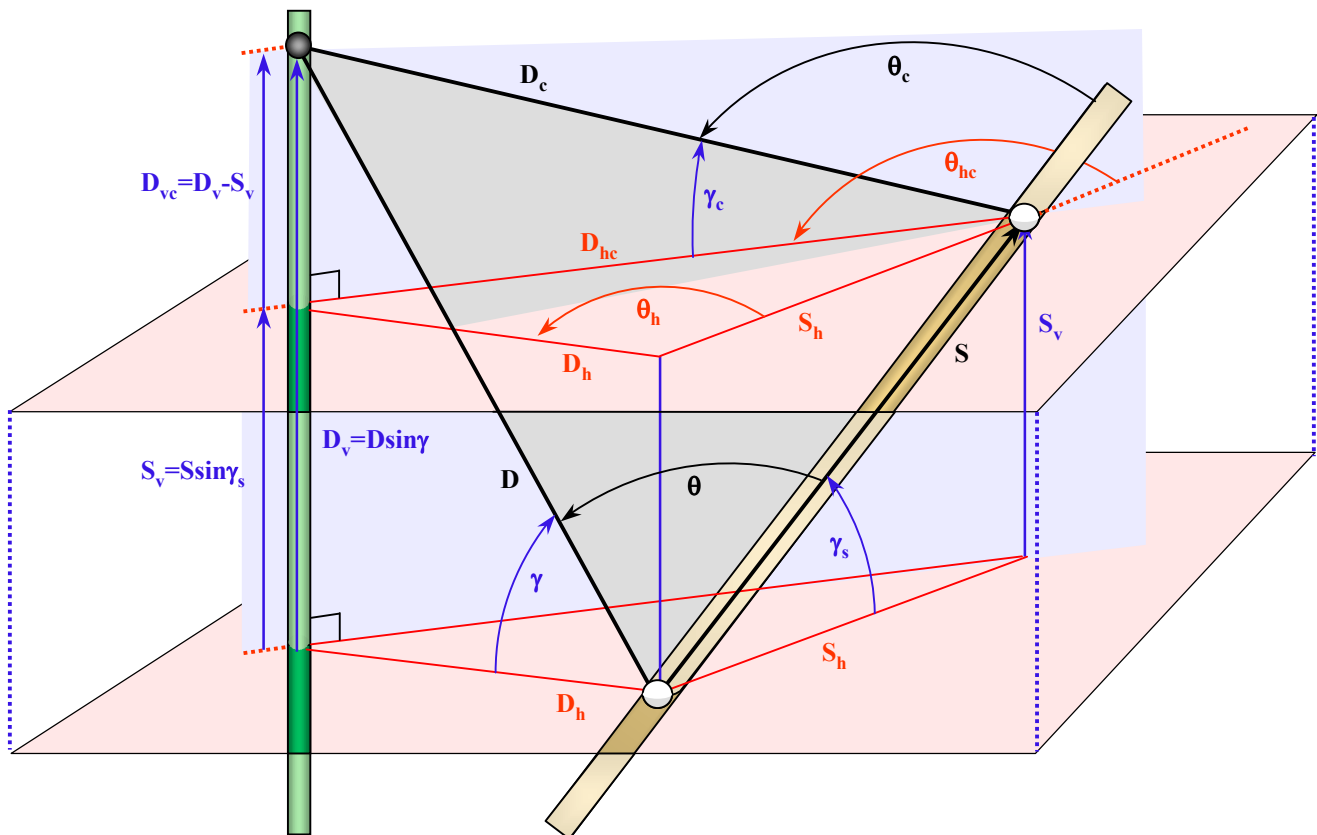

Figure 105. Oblique representation of distance and direction finding separated into vertical and horizontal components. As a convention, horizontal components are depicted in red, vertical components in blue, and oblique components in black. Although this view is mathematically equivalent to the analysis of required information, it highlights the separation of processing of relative map distance in a horizontal projection from the assessment of relative elevation. Note the separation of S and D into horizontal (S_h and D_h respectively) and vertical (S_v and D_v) components. Gravity-referent directions, as before, provide only vertical components of direction. The horizontal direction components (θ_h and θ_{hc} , as horizontal projections of θ and θ_c , respectively). Represent that part of direction that is fully independent from the information provided by gravity.

As noted previously, whether we use calculations based on direct measurement of θ or of θ_h by the spider, the information requirements of the problem do not change. As long as we have both γ and γ_s , both the strictly route-referent system, and the horizontal plane projection of the route-referent system, provide equivalent information. Gravity-referent orientation requires the use of route-referent information. Although route-referent orientation does not strictly require gravity, and could probably be used in the absence of gravity, horizontal plane projection of route-referent information absolutely requires gravity information, as shown here. It is quite possible that *horizontal projection of route-referent information* will provide a more useful reference model for salticid orientation in the future. It is certainly consistent with the observed tendency of these spiders to override strict θ information when this conflicts with γ information in a vertical plane (Figures 72-76). The integrated view should be familiar to us: *an up and down world with left and right directions in space, with many supplemental visual cues available to resolve ambiguity.*

An additional hypothesis related to the tracking of movement is warranted here. This is related to the ability of these spiders to compensate for both vertical and horizontal distances moved when jumping (*not stepping*, e.g., examples shown in Figures 27 and 31), or jumps coupled with dragline ascents (jump recovery experiments in Figures 80-81, and example in Figure 32). Recent work on targeted jumps (Hill 2006a, also see Figure 67) which indicated that these spiders braked on the dragline at a pre-determined distance during each targeted jump also supports this hypothesis [H-7]:

[H-7] The horizontal direction, horizontal distance, and vertical distance (collectively, the S_j or movement vector) associated with a jump are computed *prior to execution of that jump*.

[H-7.1] Upon completion of a jump, the spider integrates the associated movement vector (S_j) into its internal representation of location.

[H-7.2] When a jump fails, the spider does not incorporate the associated movement vector (S_j) into its internal representation of location, but recovers to its previous representation.

This hypothesis suggests many future experiments. Dragline braking at a predetermined distance does support the idea that the dragline may play an important role in the measurement of movement (magnitude of S vector) in general. Certainly the precision of many araneid webs indicates that distance measurement and silk lines are closely related in many spiders. When it comes to sophistication in the production and handling of silk, salticid spiders are also masters. They do it all day long.

Complex path integration

To support the analysis of location memory, most of the pursuit segments studied here have involved movement of spiders along linear routes. Many of the qualitative examples discussed previously (e.g., Figures 1, 2, 23, 29, 30) showed that *Phidippus* jumping spiders could complete a much more complicated path in multiple directions prior to reorientation. In a final experiment, this ability was systematically studied on a relatively simple artificial plant situation (Figures 108-110).

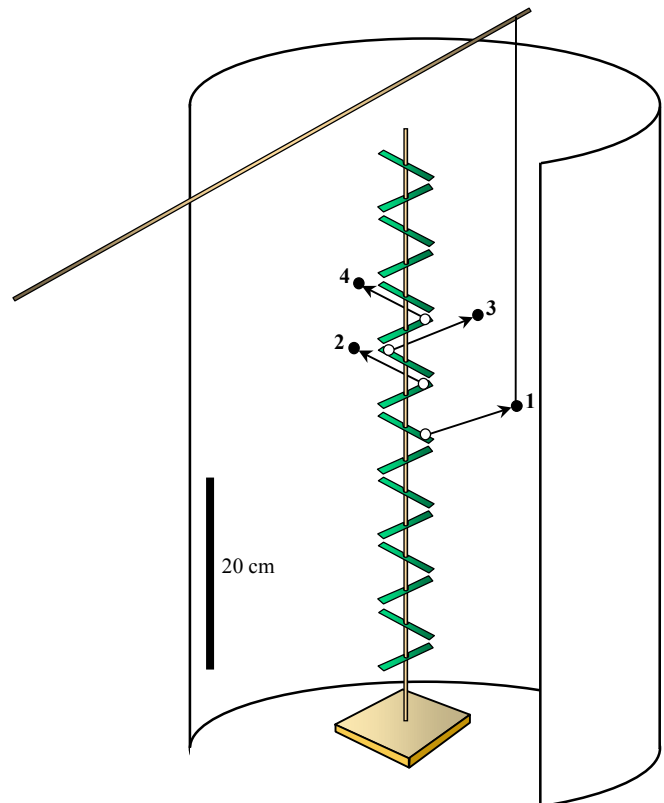

Figure 108. Perspective drawing of apparatus used to demonstrate the ability of spiders to maintain a memory of prey location during movement in multiple dimensions. Spiders were run through a succession of right-handed or left-handed trials (1-4, above) as they ascended the "plant," with the reorientation position of one trial serving as the starting position for the next trial. Leaves could also be removed and cleaned or replaced to eliminate chemical cues affecting the choice of direction of movement. The plant was placed inside of a white cylinder made from heavy paper (partial, to support observation). All pursuits were initiated with presentation of the target (standard lure) away from the open quadrant of the cylinder, as shown here. The cylinder removed most background clues, and also made the target more visible.

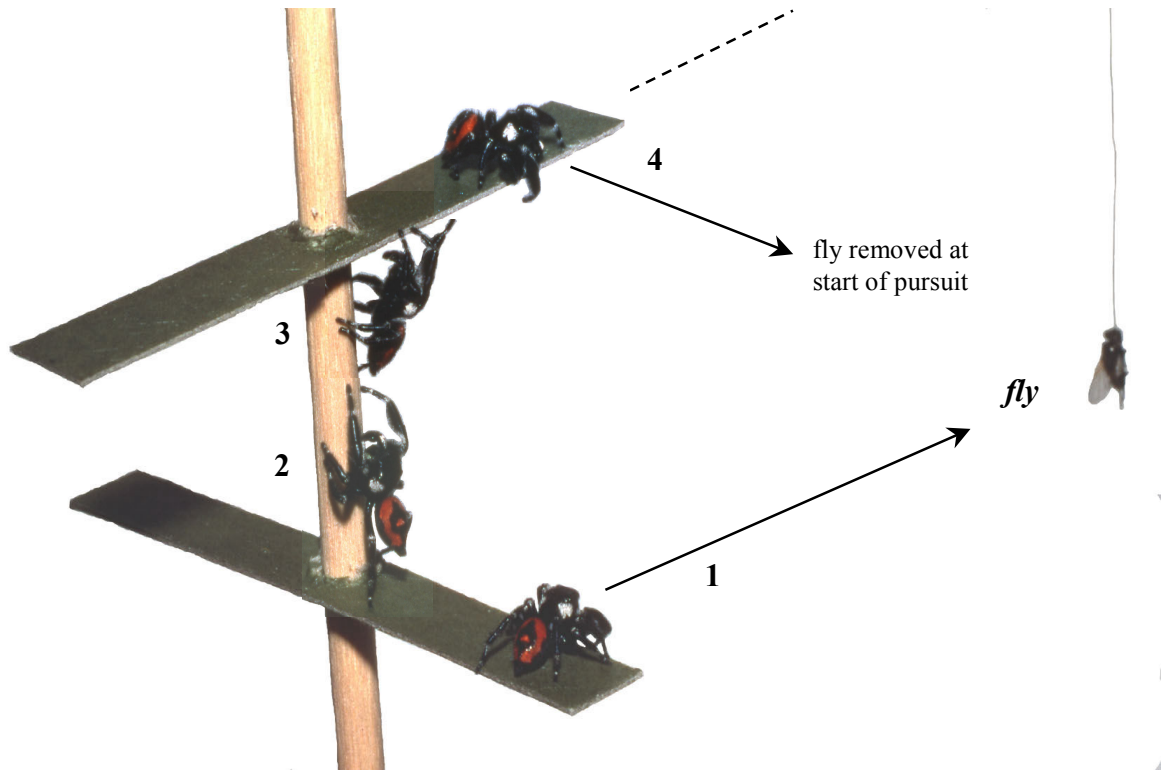

Figure 109. Photomontage of pursuit of a target (standard lure) by an adult male *P. pulcherrimus*. On this artificial plant constructed with wood dowels and heavy green paper, the target was presented at the same level as the spider ($\gamma = 0^\circ$), directly in front of the spider (with respect to the immediate route, $\theta = \theta_h = 90^\circ$), and was removed immediately as pursuit began. After the initial facing turn (1), this spider quickly turned to the left, ran to and climbed up the vertical dowel (2), turned and climbed out to and then under a second "branch" (3), and then executed an accurate reorientation turn (4), all without interruption. In the execution of this turn (4), the spider compensated for its movement to the left from position 1 by turning back to the right. It also compensated for the climb in positions 2 and 3 by turning down (4) at the same time.

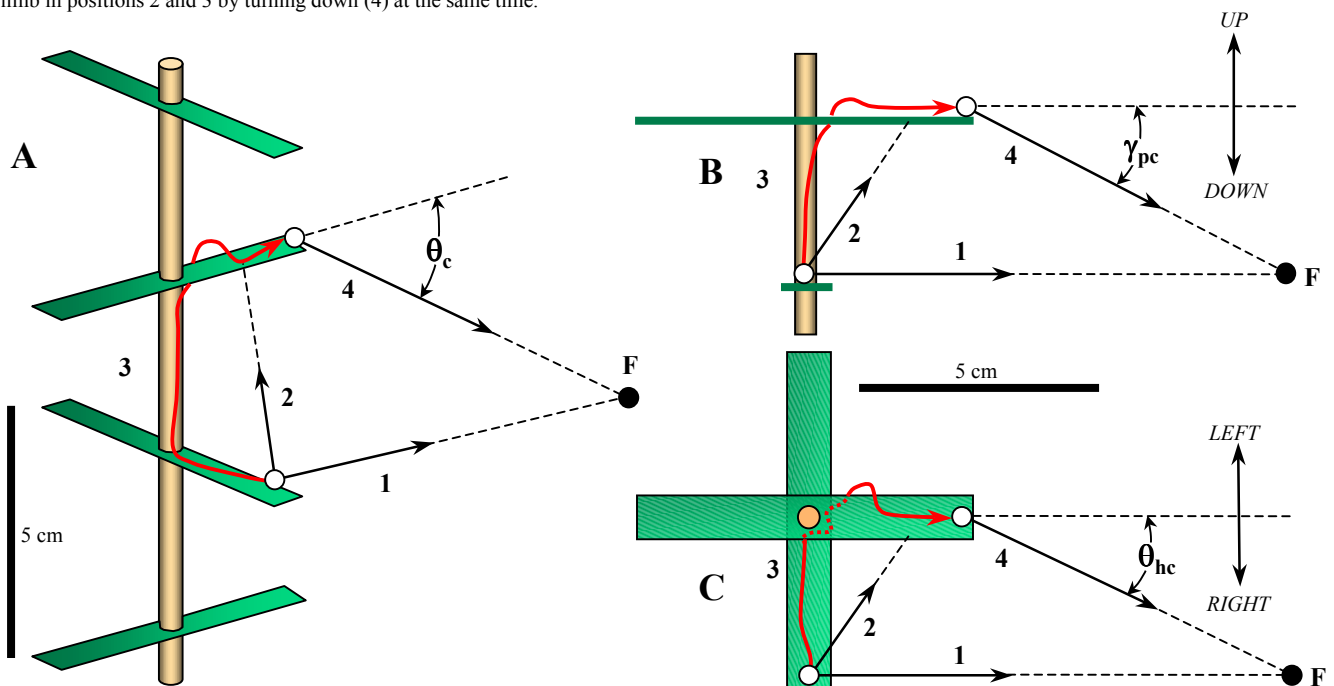

Figure 110. Demonstration of compensation for movement in three dimensions. A: Perspective drawing of apparatus. Pursuit was initiated when spiders faced the target (1, to standard lure F) at the same level at a right angle with the immediate route ($\gamma = 0^\circ$, $\theta = 90^\circ$). Many, but not all, spiders made a distinct turn from this position (2) to face a nearby branch on the plant. Spiders then turned toward the vertical stem, climbed that stem, and ran out onto the other side branch in a continuous, uninterrupted movement (3). At the end of this run, a reorientation turn was made (4). As shown in lateral view (B, vertical projection), the projected γ_c (γ_{pc}) was recorded as either *distinctly* down (compensated for ascent) or some other direction. As shown in the top-down view (C, horizontal projection), the projected θ_c (θ_{hc}) was recorded as either *distinctly* to the right (compensated for movement to the left), or as some other direction. The target (F, standard lure) was immediately removed at the onset of each pursuit. The plant consisted of a series of horizontal green paper branches skewered on a 4.5 mm diameter wooden dowel. Trials were run in either left-handed (stem to the left at start) or right-handed (stem to the right at start) configurations.

Results (Figure 111) showed that *Phidippus* jumping spiders could compensate for this complex movement, involving multiple dimensions and directions during a single segment of pursuit, to successfully determine the relative location of a target position. To compensate for γ , spiders had to integrate successive movement in the horizontal direction perpendicular to the target direction, followed by a 90° turn and movement in a vertical direction, leading to another 90° turn and more horizontal movement in a different direction. To compensate for θ , spiders also had to integrate the directional impact of three different right-angle turns (in Figure 110, to the left, then upwards, then to the right).

During vertical ascent on the stem, θ information could not have been used to determine radial direction (horizontal component). It is clear that spiders used their vision to locate the specific branch that they were pursuing as a secondary objective, and thus reasonable to assume that their radial orientation on the stem was *image-referent*. The ability to correctly compensate with an appropriate reorientation turn to the right or left shows that these spiders could *transpose horizontal direction* between a image reference system and a route reference system (which, as noted previously, can involve the use of vision to recognize the relative direction of a route). This supports the general view that these spiders maintain an *internal representation of location in three-dimensional space* that is able to draw from and integrate information collected from multiple external reference systems (route-referent, gravity-referent, or image-referent). This representation was updated during the continuous movement of spiders in a sequence of three completely different directions (Figure 112). For this, we add one more important hypothesis:

[H-8] Salticid spiders can readily transpose the internal representation of *horizontal (map or compass) direction* between route-referent and image-referent systems during movement.

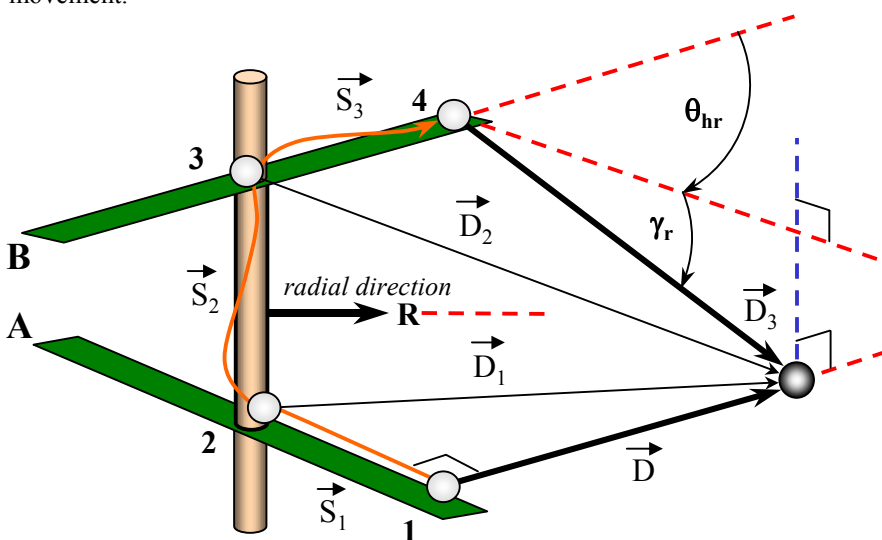

Figure 112. Vector representation of movement in three dimensions during trials described in Figures 108-111. Spiders usually moved directly from position 1 to position 4 before reorienting, as shown in Figure 105. During movement from 1 to 2, and from 3 to 4, integrated θ and γ reference systems could be used to maintain an internal representation of the relative location of the target (successive D vectors). However, during movement between positions 2 and 3, visual references provided by the plant configuration would be required to provide radial direction (horizontal component), and to establish the relationship between the respective radial directions of branches A and B (90° turn in horizontal projection). Spiders clearly oriented visually to the stem when moving from 1 to 2, and to branch B when moving from 2 to 3. Note that θ_{hr} is the horizontal projection of θ , and R represents the radial direction (always horizontal) of the target from the vertical route.

Figure 111. Results of the compensation experiment described in Figures 108-110. The direction of reorientation was recorded in each trial in which a spider (*P. pulcherrimus*) completed the indirect pursuit of the secondary objective (branch shown in Figure 110). Some individual spiders could only be enticed to perform in a few trials, while others ran this problem consistently and repeatedly. Since results for both right-handed and left-handed configurations were similar, these data have been pooled in the following general categories:

A: Both γ and θ were distinctly compensated (as shown in Figures 109 and 110, with a distinct compensation turn in both directions)

A': Both γ and θ were distinctly compensated, but the spider ran down to a lower branch instead of a higher branch

B: Only γ was distinctly compensated with a turn down, and the spider either turned to the opposite θ direction (right or left), or faced straight ahead

C: Only θ was distinctly compensated with a turn to the right or left, and the direction faced by the spider was either horizontal or up from the reorientation position.

D: Neither γ nor θ was distinctly compensated for movement

Compensation for movement in both directions was observed in a highly significant majority ($P < 0.0001$) of the trials, and there were very few trials in which compensation did not take place in at least one dimension.

SN	N	A	A'	B	C	D
3fPUL	5	4	0	1	0	0
5fPUL	1	1	0	0	0	0
9fPUL	6	3	1	2	0	0
11fPUL	52	39	1	2	9	1
13fPUL	59	49	0	7	3	0
16mPUL	12	10	0	2	0	0
17mPUL	37	31	0	4	1	1
18mPUL	30	21	2	2	5	0
Total PUL	202	158	4	20	18	2

This ability to transpose between reference systems was also demonstrated in most of the qualitative examples of detoured pursuit that we reviewed earlier (e.g., Figures 20-22, 33). In many of these examples, spiders moved from one leaf or branch to a stem, moved along that stem, and then moved back out on a different branch. Most of these examples involved far more complicated routes, including oblique routes, when compared to the relatively simple experiment depicted in Figures 108-112.

This ability to maintain an accurate internal representation of horizontal direction when moving between vertical and horizontal routes also supports the hypothesis [H-6] that horizontal direction (and distance) is processed separately from elevation by these spiders. This is because the transposition between route-referent direction to radial or image-referent direction (at position 2 in Figure 112) removed the utility of the original θ , since the orientation of the branch on which the spider began its pursuit was no longer relevant to determination of direction in space. Unlike θ , the radial direction (R, see Figure 112) during vertical ascent only corresponded to horizontal direction. When the spider again moved out onto a branch, the direction R could again be transposed into route-referent memory of direction, relative to the new direction of horizontal movement. During vertical movement, neither R (radial, horizontal direction) nor the horizontal distance of the target (D_{hc}) change. Even when moving from oblique to vertical routes, and vice-versa, the transposition between θ_h (which only represents horizontal direction) and R would be much simpler (Figure 113).

As shown in figure 113, this transposition requires an ability by the spider to convert θ_h information into radial direction (R, at position 2), and also to convert R information back into θ_h (at position 3). We have already discussed the ability of these spiders to use image-referent orientation (e.g., differences in background illumination, or specific plant objects) to maintain R during vertical ascent (movement from 2 to 3). Transposition from θ_{h2} to R requires the ability to use θ_h to define one side of the stem (R), which is then associated with visual features as seen from that stem (most likely, the image of the side branches above the spider in this example). Similarly, transposition from R to θ_{h3} requires the spider to assess the horizontal direction of the second branch relative to this side of the stem (R). The simplifying factors associated with vertical movement include the constancy of R and D_h during this movement, as well as the fact that $S_h=0$. This leaves the spider with the task of maintaining only horizontal direction (R) and relative elevation during vertical movement.

Figure 113. Movement between oblique and vertical routes during pursuit. Two artificial plants like this one (A, perspective view) were constructed and used in the qualitative observation of detoured pursuit (see Figure 26). A: This pursuit includes three segments of movement (S1 to S3), oblique downward, vertical, and then oblique upward in a different horizontal direction. B: Projection of vertical movement. As shown here, tracking of the *relative elevation* component is relatively simple, and the formula for computation of $S_v (= \sin\gamma s)$ is invariant. On a horizontal surface, $\sin\gamma s$ and hence S_v would both be =0. Sequential positions (1-4) are shown at the bottom of each column. C: Horizontal projection, as seen from above. Computation of relative distance (D) and direction (θ_h) during movement from 1 to 2, and from 3 to 4, was covered previously. During vertical movement (2 to 3), there is no horizontal displacement ($S_h=0$), and the horizontal direction and distance of the target does not change ($D_{h2}=D_{h3}$). The only new capability, as presented in hypothesis [H-8], is the ability to transpose from θ_{h2} to R at 2, to maintain the estimate of R during ascent from 2 to 3, and then to transpose R back to θ_{h3} at 3.

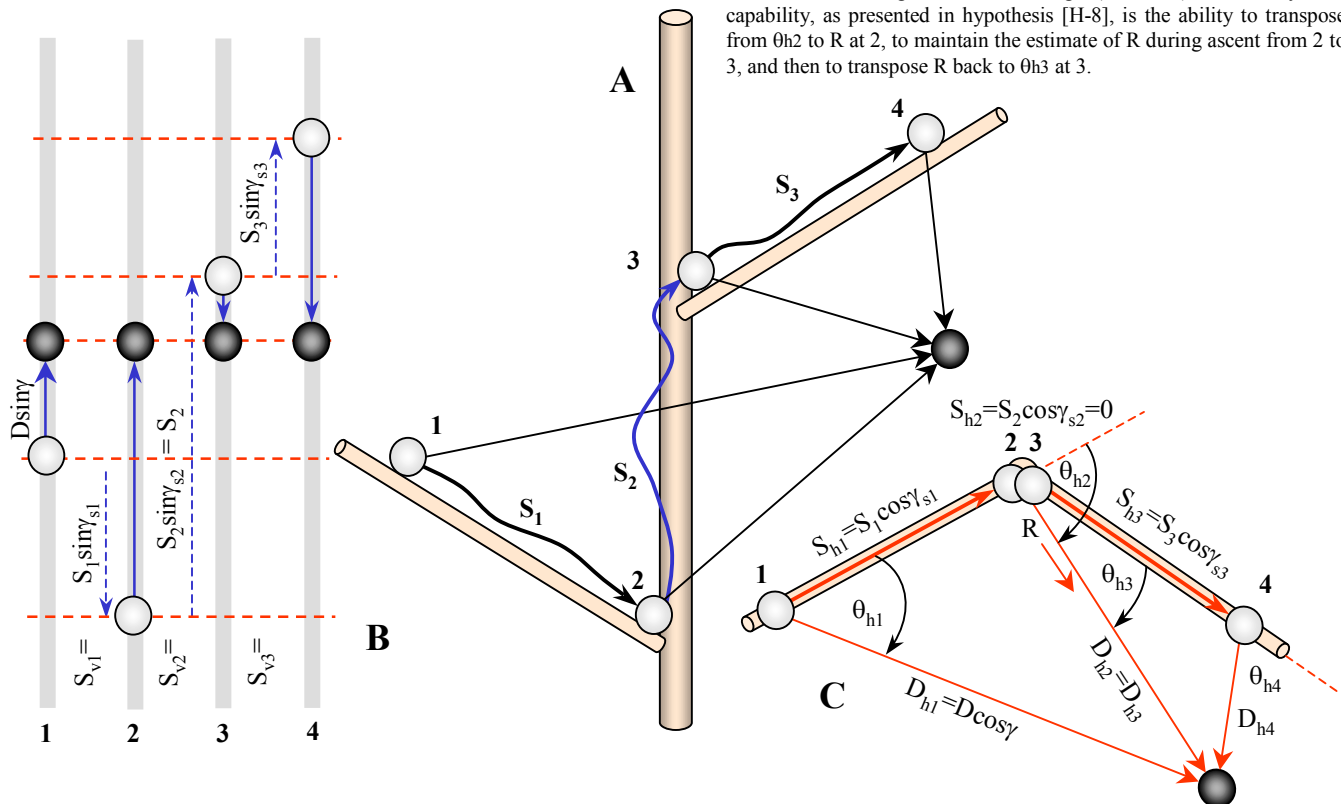

15. Discussion

The mathematical analysis of external reference systems used to determine location, as described here, is generally applicable to directed movement in the terrestrial environment. In fact, since these studies were completed, similar triangulation experiments have been performed on human subjects, with similar results (e.g., Philbeck, Loomis, and Beall 1997). Given our own lack of adhesive footpads and our limited capability to move in a vertical environment when compared to a salticid spider (!), it may be some time before we see our own species subjected to many of these *three-dimensional* problems. Nonetheless, three-dimensional orientation is well-known in arboreal mammals (e.g., *Sciurus*, Jacobs and Shiflett 1999).

Since many different terrestrial/arboreal animals share the same environment, it is likely that we will find many analogous mechanisms in other organisms when we look for them. We don't know how mathematical computations are actually performed in any central nervous system, but the various representations that we can use for this (e.g., vector geometry, or trigonometry) are essentially equivalent and useful for the analysis of problem constraints and opportunities. In the present analysis, for example, this has revealed the likelihood of a running memory of relative target location that includes the repeated computation of a target distance estimate from new positions.

In fact, separate maintenance of vertical (elevation) and horizontal (map or compass) distance estimates, as depicted here, may represent the *simplest* mathematical approach to computation of relative direction by animals moving in three dimensions within a gravitational field, and this is most likely a good model or hypothesis for a very general capability. This is particularly true when organisms transpose between alternative reference systems for the determination of horizontal direction, as do salticid spiders.

My recent work on the targeted jumps of *Phidippus* (Hill 2006a) also demonstrated that these spiders evaluate both target distance and target direction with respect to gravity. Recent field observations of the salticid *Anasaitis canosa* (Hill 2006b) showed that these leaf litter salticids can complete indirect pursuits in the manner that has been demonstrated for *Phidippus*, and there is no reason to believe that the general mechanisms proposed here are not applicable to the Salticidae (jumping spiders) as a group. As mentioned in the introduction, more recent work on other salticid spiders has corroborated this view.

Although this work focused on predatory behavior, many of the examples of this behavior also depicted the pursuit of plant positions (termed secondary objectives in the context of pursuit of a primary objective) by these spiders. Spatial reference systems are relevant to all directed movement by these spiders, including searching or more general foraging, when they can be seen to identify and then to move via indirect routes to sighted positions or objectives. The suggestion that salticids can nest even more layers of location objectives (e.g., a tertiary objective used to attain the position of a secondary objective) is of interest, as it implies the ability to retain a simultaneous memory of multiple locations. This is the key to the successful negotiation of complex routes of pursuit. It has also been frequently observed that *Phidippus* can return to successfully complete a pursuit after they have been distracted or turn to look in a different direction, or after they take a dead-end path and have to back-track toward the primary objective.

In the course of this work, *Phidippus* jumping spiders often executed *direct* turns to face *stationary plant objects* that were relevant to determining the direction of pursuit (e.g., Figure 41). The set of *internal concepts* used by these spiders with respect to the functional classification of environmental objects deserves much more study (Figure 114). This could also help to resolve questions related to their diverse habitat partitioning and distribution (Edwards 1980).



Figure 114. Adult female *Phidippus pulcherrimus* reared from immature captured in Ocala National Forest, Marion County, Florida. One of the most endearing aspects of these spiders is a result of the subtle ρ turns that they make as they align to observed objects. Just what they are looking at, and what objects they can recognize, are of greatest interest.

15. Acknowledgments

I would like to thank the following individuals for their personal enthusiasm, support and respective intellectual contributions to these studies: Dr. John F. Anderson, Dr. James E. Lloyd, Dr. Jonathan Reiskind (University of Florida), Dr. Thomas Eisner (Cornell University), Dr. G. B. Edwards (Florida Division of Plant Industry), and Dr. David B. Richman (New Mexico State University).

16. References

Akre, R. D. 1964 Correcting behavior by insects on vertical and horizontal mazes. *Journal of the Kansas Entomological Society* 37: 169-186.

Bartels, M. 1929 Sinnesphysiologische und psychologische Untersuchungen an der Trichterspinnne *Agelena labyrinthica* (Cl.). *Zeitschrift für vergleichende Physiologie* 10: 527-593.

Bartels, M., and Balzer, F. 1928 Über Orientierung und Gedächtnis der Netzspinne *Agelena labyrinthica*. *Revue Suisse de Zoologie* 35: 247-258.

Barth, F. G. 1976 Sensory information from strans in the exoskeleton. In: *The Insect Integument*, ed. H. R. Hepburn, Elsevier, Amsterdam: 445-473.

Bennett, T. J., and Lewis, R. J. 1979 Visual orientation in the Salticidae (Araneae). *New Zealand Entomologist* 7 (1): 58-63.

Bilsing, S. W. 1920 Quantitative studies in the food of spiders. *Ohio Journal of Science* 20: 215-260.

Blake, R., Camisa, J. M., and Antoinetti, D. N. 1976 Binocular depth discrimination depends on orientation. *Perceptual Psychophysiology* 20: 113-118.

Blest, A. D. 1983 Ultrastructure of secondary retinæ of primitive and advanced jumping spiders (Araneae, Salticidae). *Zoomorphology* 102: 125-141.

Blest, A. D. 1984 Secondary retinæ of a primitive jumping spider, *Yaginumanis* (Arachnida, Araneida, Salticidae). *Zoomorphology* 104: 223-225.

Blest, A. D. 1985 Retinal mosaics of the principal eyes of jumping spiders (Salticidae) in some neotropical habitats: optical trade-offs between sizes and habitat illuminances. *Journal of Comparative Physiology A* 157: 391-401.

Blest, A. D. 1990 Comparative ultrastructure of layer I receptor mosaics in principal eyes of jumping spiders: the evolution of regular arrays of light guides. *Cell and Tissue Research* 262: 445-460.

Blest, A. D., Hardie, R. C., McIntyre, P., and Williams, D. S. 1981 The spectral sensitivities of identified receptors and the function of retinal tiering in the principal eyes of a jumping spider. *Journal of Comparative Physiology* 145: 227-239.

Blest, A. D., McIntyre, P., and Carter, M. 1988 A re-examination of the principal retinæ of *Phidippus johnsoni* and *Plexippus validus* (Araneae: Salticidae): implications for optical modeling. *Journal of Comparative Physiology A* 162: 47-56.

Blest, A. D., and Sigmund, C. 1985 Retinal mosaics of a primitive jumping spider, *Sparteus* (Salticidae: Araneae): a transition between principal retinæ serving low and high spatial acuities. *Protoplasma* 125: 129-139.



- Burger, M. L. 1971** Zum Mechanismus der Gegenwendung nach mechanisch aufgezwungener Richtungsänderung bei *Schizophyllum sabulosum* (Julidae, Diplopoda). Zeitschrift für vergleichende Physiologie 71: 219-254.
- Burkhalter, A. 1972** Distance measuring as influenced by terrestrial cues in *Cataglyphis bicolor* (Formicidae, Hymenoptera). In: Information Processing in the Visual Systems of Arthropods, ed. R. Wehner, Springer-Verlag, Berlin: 303-308.
- Crane, J. 1949** Comparative behavior of salticid spiders at Rancho Grande, Venezuela. IV. An analysis of display. Zoologica 34: 159-214.
- Dacke, M., Doan, T. A., and O'Carroll, D. C. 2001** Polarized light detection in spiders. The Journal of Experimental Biology 204: 2481-2490.
- Dacke, M., Nilsson, D. E., Warrant, E. J., Blest, A. D., Land, M. F. and O'Carroll, D. C. 1999** Built-in polarizers form part of a compass organ in spiders. *Nature* 401, 470-473.
- DeVoe, R. D. 1975** Ultraviolet and green receptors in the principal eyes of jumping spiders. Journal of General Physiology 66: 193-207.
- DeVoe, R. D., and Zvargulis, J. E. 1967** Spectral sensitivities of vision in wolf spiders and jumping spiders. Federation Proceedings 26: 655.
- Dill, L. M. 1975** Predatory behavior of the zebra spider, *Salticus scenicus* (Araneae, Salticidae). Canadian Journal of Zoology 53: 1284-1289.
- Dornfeldt, K. 1975a** The role of the principal and accessory eyes in the photomenotactic orientation of the funnel spider *Agelena labyrinthica* (Cl.). Zeitschrift für Tierpsychologie 38: 113-153.
- Dornfeldt, K. 1975b** The control system of homing in the spider *Agelena labyrinthica* (Cl.). Zeitschrift für Tierpsychologie 38: 267-293..
- Drees, O. 1952** Untersuchungen über die angeborenen Verhaltensweisen bei Springspinnen (Salticidae). Zeitschrift für Tierpsychologie 9: 169-207.
- Duelli, P. 1976** Distance training on carried ants (*Cataglyphis bicolor* Fabr., Hymenoptera, Formicidae). Revue Suisse de Zoologie 83: 413-418.
- Duelli, P. 1977** Evidence for an off-pass filter in the movement detecting system of jumping spiders (*Evarcha arcuata*, Salticidae). Proc. Australian Physiol. Pharmacol. Soc. 8: 98.
- Duelli, P. 1978** Movement detection in the posterolateral eyes of jumping spiders (*Evarcha arcuata*, Salticidae). Journal of Comparative Physiology 124: 15-26.
- Duelli, P. 1980** The neuronal organization of the posterior lateral eyes of jumping spiders (Salticidae). Zoologisches Jahrbuch Abteilung Anatomie 103: 17-40.
- Dzimirski, I. 1959** Untersuchungen über Bewegungssehen und Optomotorik bei Springspinnen (Salticidae). Zeitschrift für Tierpsychologie 16: 385-402.
- Eakin, R. M., and Brandenburger, J. L. 1971** Fine structure of the eyes of jumping spiders. Journal of Ultrastructure Research 37: 618-663.
- Edwards, G. B. 1980** Taxonomy, ethology, and ecology of *Phidippus* (Araneae: Salticidae) in eastern North America. Ph.D. Dissertation, University of Florida: i-vii, 1-353.
- Edwards, G. B. 2004** Revision of the jumping spiders of the genus *Phidippus* (Araneae: Salticidae). Occasional Papers of the Florida State Collection of Arthropods 11: i-viii, 1-156.
- Edwards, G. B., and Jackson, R. R. 1993** Use of prey-specific predatory behaviour by North American jumping spiders (Araneae, Salticidae) of the genus *Phidippus*. Journal of Zoology, London 229: 709-716.
- Enders, F. 1975** The influence of hunting manner on prey size, particularly in spiders with long attack distances (Araneidae, Linyphiidae, and Salticidae). The American Naturalist 109: 737-763.
- Forster, L. M. 1977** A qualitative analysis of hunting behaviour in jumping spiders (Araneae: Salticidae). New Zealand Journal of Zoology 4: 51-62.
- Frisch, K. V., and Jander, R. 1957** Über den Schwanzeltanz der Bienen. Zeitschrift für vergleichende Physiologie 40: 239-263.
- Gardner, B. T. 1964** Hunger and sequential responses in the hunting behavior of salticid spiders. Journal of Comparative and Physiological Psychology 58: 167-173.
- Gardner, B. T. 1965** Observations on three species of *Phidippus* jumping spiders (Araneae: Salticidae). Psyche 72: 133-147.
- Gorner, P. 1958** Die optische und kinasthetische Orientierung der Trichterspinnne *Agelena labyrinthica*. Zeitschrift für vergleichende Physiologie 41: 111-153.
- Gorner, P. 1962** Die Orientierung der Trichterspinnne nach polarisierten Licht. Zeitschrift für vergleichende Physiologie 45: 307-314.
- Gorner, P. 1966** Über die Koppelung der optischen und kinasthetischen Orientierung bei den Trichterspinnne *Agelena labyrinthica* (Clerck) und *Agelena graciliens* C. L. Koch. Zeitschrift für vergleichende Physiologie 53: 253-276.
- Greenquist, E. A., and Rovner, J. S. 1976** Lycosid spiders on artificial foliage: stratum choice, orientation preferences, and prey-wrapping. Psyche 83: 196-209.
- Hardie, R. C., and Duelli, P. 1978** Properties of single cells in posterior lateral eyes of jumping spiders. Z. Naturforsch. 33c: 156-158.

- Heil, K. H. 1936** Beitrage zur Physiologie und Psychologie der Springspinnen. Zeitschrift fur vergleichende Physiologie 23: 1-25.
- Henton, W. W., and Crawford, F. T. 1966** The discrimination of polarized light by the tarantula. Zeitschrift fur vergleichende Physiologie 52: 26-32.
- Hill, D. E. 1975** The structure of the central nervous system of jumping spiders of the genus *Phidippus* (Araneae: Salticidae). M. S. Thesis, Oregon State University: 1-94.
- Hill, D. E. 1977** Field observations on the behavior of immature *Phidippus princeps* in Minnesota. Peckhamia 1 (3): 44-50.
- Hill, D. E. 1978a** The behavior of *Eris marginata* (Araneae: Salticidae). Peckhamia 1 (4): 63-70.
- Hill, D. E. 1978b** Orientation by jumping spiders of the genus *Phidippus* (Araneae: Salticidae) during the pursuit of prey. Ph.D. Dissertation, University of Florida, i-v, 1-202.
- Hill, D. E. 1979** Orientation by jumping spiders of the genus *Phidippus* (Araneae: Salticidae) during the pursuit of prey. Behavioral Ecology and Sociobiology 6: 301-322.
- Hill, D. E. 2006a** Targeted jumps by salticid spiders (Araneae, Salticidae, *Phidippus*). Version 6: 1-9.
- Hill, D. E. 2006b** Predatory pursuit of ants by *Anasaitis canosa* (Araneae, Salticidae). Version 2: 1-6.
- Hollis, J. H., and Branson, B. A. 1964** Laboratory observations on the behavior of the salticid spider *Phidippus audax* (Hentz). Transactions of the Kansas Academy of Science 67: 131-148.
- Holzapfel, M. 1933** Die nicht-optische Orientierung der Trichterspinnne *Agelena labyrinthica* (Cl.). Zeitschrift fur vergleichende Physiologie 20: 55-116.
- Homann, H. 1928** Beitrage zur Physiologie der Springspinnenaugen. II. Das Sehvermogen der Salticiden. Zeitschrift fur vergleichende Physiologie 7: 229-268.
- Horridge, G. A. 1977** Insects which turn and look. Endeavour (new series) 1: 1-17.
- Jackson, R. R., and Wilcox, R. S. 1993** Observations in nature of detouring behaviour by *Portia fimbriata*, a web-invading aggressive mimic jumping spider from Queensland. Journal of Zoology, London 230: 135-139.
- Jacobs, L. F., and Shiflett, M. W. 1999** Spatial orientation on a vertical maze in free-renging fox squirrels (*sciurus niger*). Journal of Comparative Psychology 113 (2): 116-127.
- Kaestner, A. 1950** Reaktion der Hupfspinnen (Salticidae) auf unbewegte farblose und farbige Gesichtszweize. Zoologische Beitrage, Berlin 1: 12-50.
- Land, M. F. 1969a** Structure of the retinae of the principal eyes of jumping spiders (Salticidae: Dendryphantinae) in relation to visual optics. Journal of Experimental Biology 51: 443-470.
- Land, M. F. 1969b** Movements of the retinae of jumping spiders (Salticidae: Dendryphantinae) in response to visual stimuli. Journal of Experimental Biology 51: 471-493.
- Land, M. F. 1971** Orientation by jumping spiders in the absence of visual feedback. Journal of Experimental Biology 54: 119-139.
- Land, M. F. 1972a** Stepping movements made by jumping spiders during turns mediated by the lateral eyes. Journal of Experimental Biology 57: 15-40.
- Land, M. F. 1972b** Mechanisms of orientation and pattern recognition by jumping spiders (Salticidae). In: Information Processing in the Visual Systems of Arthropods, ed. R. Wehner, Springer-Verlag, Berlin: 231-247.
- Land, M. F. 1974** A comparison of the visual behavior of a predatory arthropod with that of a mammal. In: The Neurosciences: Third Study Program, ed. F. O. Schmidt and F. G. Worden, MIT Press, Cambridge, Massachusetts: 411-418.
- Land, M. F. 1985** Fields of view of the eyes of primitive jumping spiders. Journal of Experimental Biology 119: 381-384.
- Leguelte, L. 1969** Learning in spiders. American Zoologist 9: 145-152.
- Lim, M. L. M., and Li, D. 2006** Behavioural evidence of UV sensitivity in jumping spiders (Araneae: Salticidae). Journal of Comparative Physiology A 192: 871-878.
- Maddison, W. P., and Hedin, M. C. 2003** Jumping spider phylogeny (Araneae: Salticidae). Invertebrate Systematics 17: 529-549.
- Mendenhall, W., and Schaeffer, L. 1973** Mathematical Statistics with Applications. Duxbury Press, North Scituate, Massachusetts: 1-561.
- Mittelstaedt, H. 1962** Control systems of orientation in insects. Annual Review of Entomology 7: 177-198.
- Mittelstaedt, H. 1964** Basic control patterns of orientational homostasis. Society for Experimental Biology, Symposia 18: 365-386.
- Peters, H. 1932** Experimente uber die Orientierung der Kreuzspinnne *Epeira diademata* Cl. In Netz. Zoologischer Jahrbucher, Abteilung fur allgemeine Zoologie und Physiologie der Tiere 51: 239-288.
- Peaslee, A. G., and Wilson, G. 1989** Spectral sensitivity in jumping spiders. Journal of Comparative Physiology A 164: 359-363.
- Petrunkevitch, A. 1907** Studies in adaptation. I. The sense of sight in spiders. Journal of Experimental Zoology 5: 275-309.

- Philbeck, J. W., Loomis, J. M., and Beall, A. C. 1997** Visually perceived location is an invariant in the control of action. *Perception and Psychophysics* 59 (4): 601-612.
- Plett, A. 1962a** Untersuchungen zum Appetenzverhalten der Springspinne *Epiblemum scenicum* Cl. (Salticidae) und des Ameisenlowen *Euroleon nostras* Fourcr. (Myrmeleontidae). *Zoologischer Anzeiger* 169: 280-291.
- Plett, A. 1962b** Beobachtungen und Versuche zum Revier und Sexualverhalten von *Epiblemum scenicum* Cl. und *Evarcha blancardi* Scop. (Salticidae). *Zoologischer Anzeiger* 169: 292-298.
- Robinson, M. H. 1969** Predatory behavior of *Argiope aurantia*. *American Zoologist* 9: 161-173.
- Robinson, M. H., and Valerio, C. E. 1977** Attacks on large or heavily defended prey by tropical salticid spiders. *Psyche* 84 (1):1-10.
- Runyon, R. P., and Haber, A. 1971** Fundamentals of Behavioral Statistics. Addison-Wesley, Reading, Massachusetts: 1-351.
- Schaefer, M. W. 1975a** Gegendrehung und Winkelsinn in der Orientierung von *Lithobius forficatus* L. Teil I. Nachweis der Winkelsinnes, Charakterisierung der Orientierungsleistung. *Behaviour* 55: 15-41.
- Schaefer, M. W. 1975b** Gegendrehung und Winkelsinn in der Orientierung von *Lithobius forficatus* L. Teil II. Die ausseren und inneren Bezugspunkte. *Behaviour* 55: 42-72.
- Siegel, S. 1956** Nonparametric Statistics for the Behavioral Sciences. McGraw Hill, New York: 1-312.
- Stalleicken, J., Mukhida, M., Labhart, T., Wehner, R., Frost, B., and Mouritsen, H. 2005** Do monarch butterflies use polarized skylight for migratory orientation? *The Journal of Experimental Biology* 208: 2399-2408.
- Tarsitano, M. S., and Andrew, R. 1999** Scanning and route selection in the jumping spider *Portia labiata*. *Animal Behaviour* 58: 255-265.
- Tarsitano, M. S., and Jackson, R. R. 1992** Influence of prey movement on the performance of simple detours by jumping spiders. *Behaviour* 123 (1-2): 106-120.
- Tarsitano, M. S., and Jackson, R. R. 1994** Jumping spiders make predatory detours requiring movement away from prey. *Behaviour* 131 (1-2): 65-73.
- Tarsitano, M. S., and Jackson, R. R. 1997** Araneophagic jumping spiders discriminate between detour routes that do and do not lead to prey. *Animal Behaviour* 53 (2): 257-266.
- Tryon, R. C. 1940** Genetic differences in maze-learning ability in rats. *Yearbook of the National Society for the Study of Education* 39: 111-119.
- Turnbull, A. L. 1964** The search for prey by a web-building spider *Achaearanea tepidariorum* (C. L. Koch) (Araneae, Theridiidae). *Canadian Entomologist* 96: 568-579.
- Wehner, R. 2001** Polarization vision - a uniform sensory capacity? *The Journal of Experimental Biology* 204: 2589-2596.
- Williams, D. S., and McIntyre, P. 1980** The principal eyes of a jumping spider have a telephoto component. *Nature* 288: 578-580.
- Wilson, D. H., and Hoy, R. R. 1968** Optomotor reaction, locomotory bias and reactive inhibition in the milkweed bug *Oncopeltus* and the beetle *Zophobas*. *Zeitschrift für vergleichende Physiologie* 58: 136-152.
- Wigglesworth, V. B. 1972** The Principles of Insect Physiology. Seventh Edition. Chapman and Hall, London: i-viii, 1-827.
- Yamashita, S., and Tateda, H. 1976** Spectral sensitivities of jumping spider eyes. *Journal of Comparative Physiology* 105: 29-41.